



US00D356058S

# United States Patent [19]

[11] Patent Number: **Des. 356,058**

Newton

[45] Date of Patent: **\*\* Mar. 7, 1995**

[54] **BOAT AND TRAILER PROTECTOR SET**

4,934,302 6/1990 Harper ..... 280/414.1  
4,962,719 10/1990 Hughes et al. .... 114/343

[76] Inventor: **Donald R. Newton**, 3901 N.  
Kickapoo, #11, Shawnee, Okla.  
74801

### OTHER PUBLICATIONS

The Snow Company, Jan. 1965, front cover, the utility trailer.

[\*\*] Term: **14 Years**

*Primary Examiner*—Wallace R. Burke  
*Assistant Examiner*—M. Brown  
*Attorney, Agent, or Firm*—Dunlap & Codding

[21] Appl. No.: **9,344**

[22] Filed: **Jun. 8, 1993**

[52] U.S. Cl. .... **D12/106; D12/317;**  
D12/101

### [57] CLAIM

[58] Field of Search ..... D12/106, 101, 317, 318,  
D12/168; 280/414.1, 414.2, 414.3; 114/361,  
39.1, 219, 343

The ornamental design of a boat and trailer protector set, as shown and described.

### DESCRIPTION

### [56] References Cited

#### U.S. PATENT DOCUMENTS

|            |         |                   |           |
|------------|---------|-------------------|-----------|
| D. 318,839 | 8/1991  | Glenn et al. .... | D12/317   |
| D. 348,647 | 7/1994  | Hull et al. ....  | D12/317   |
| 3,653,677  | 4/1972  | Feser .....       | D12/101   |
| 4,781,392  | 11/1988 | Cooper .....      | 280/414.1 |
| 4,815,412  | 3/1989  | Cassaro, Jr. .... | 114/343   |

FIG. 1 is a perspective view of a boat and trailer protector set showing my new design;  
FIG. 2 is a front elevational view thereof;  
FIG. 3 is a side elevational view thereof;  
FIG. 4 is an opposite side elevational view thereof; and,  
FIG. 5 is a top plan view thereof.  
The broken lines shown in FIGS. 1-5 are for illustrative purposes only and form no part of the claimed design.

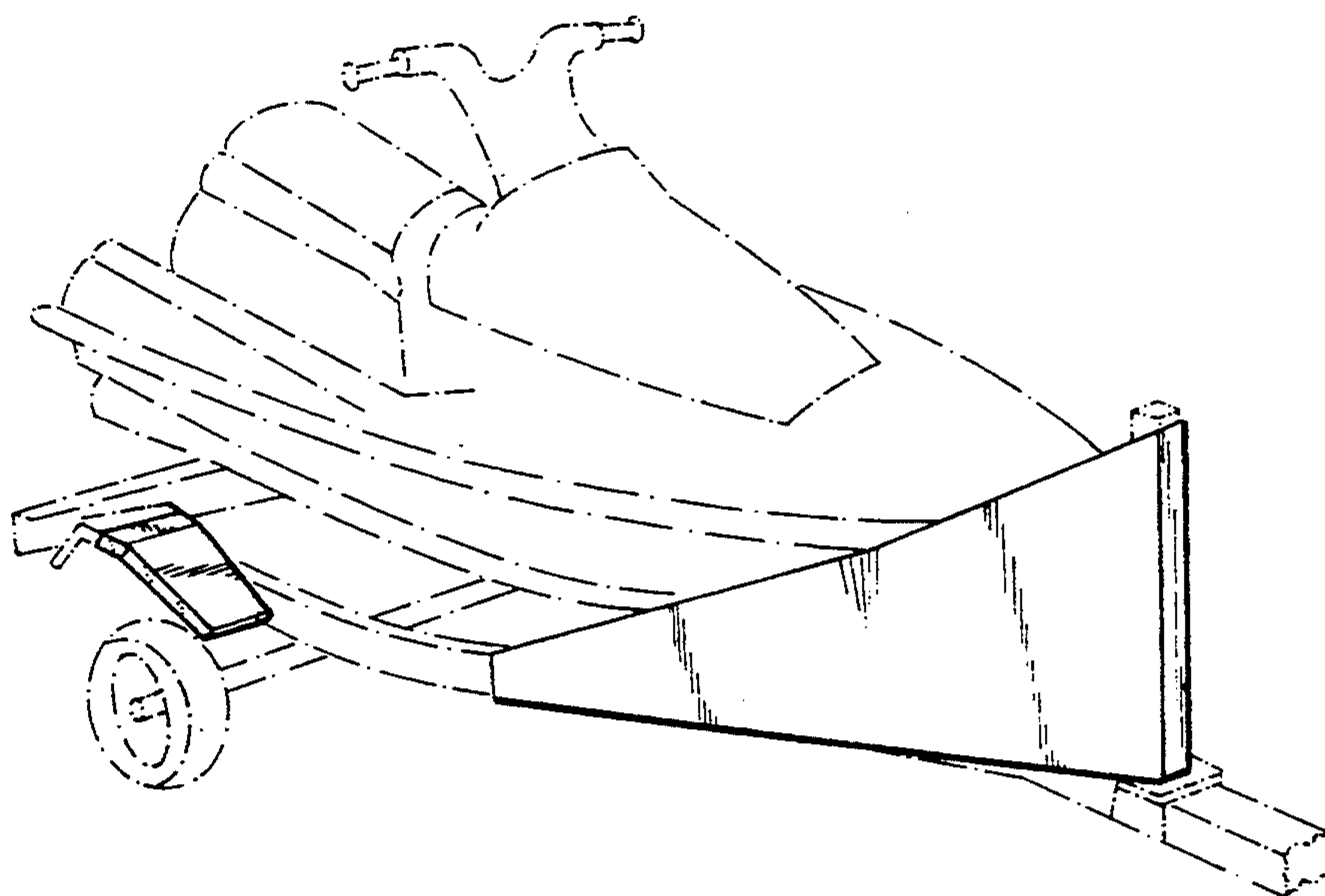

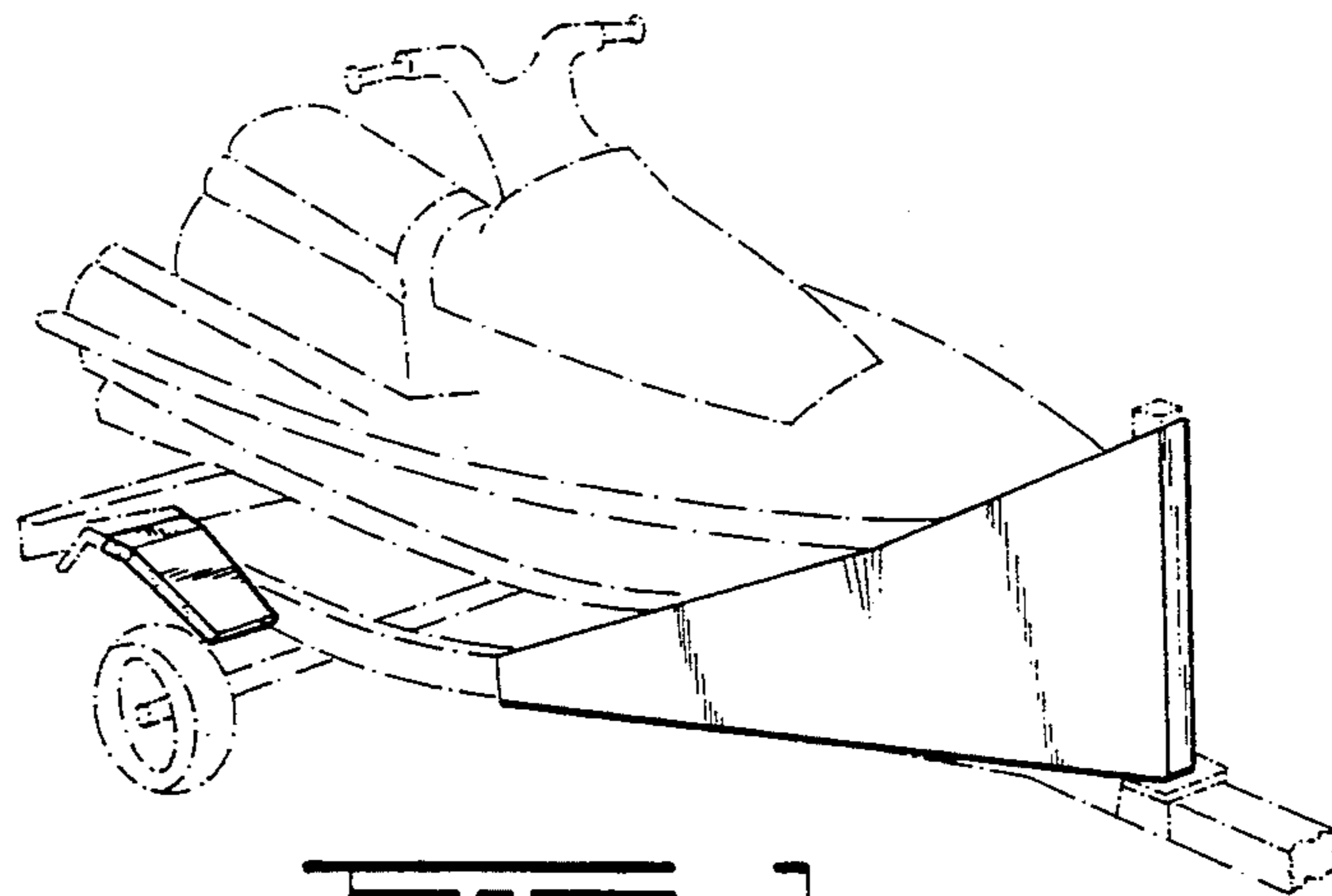

FIG. 1

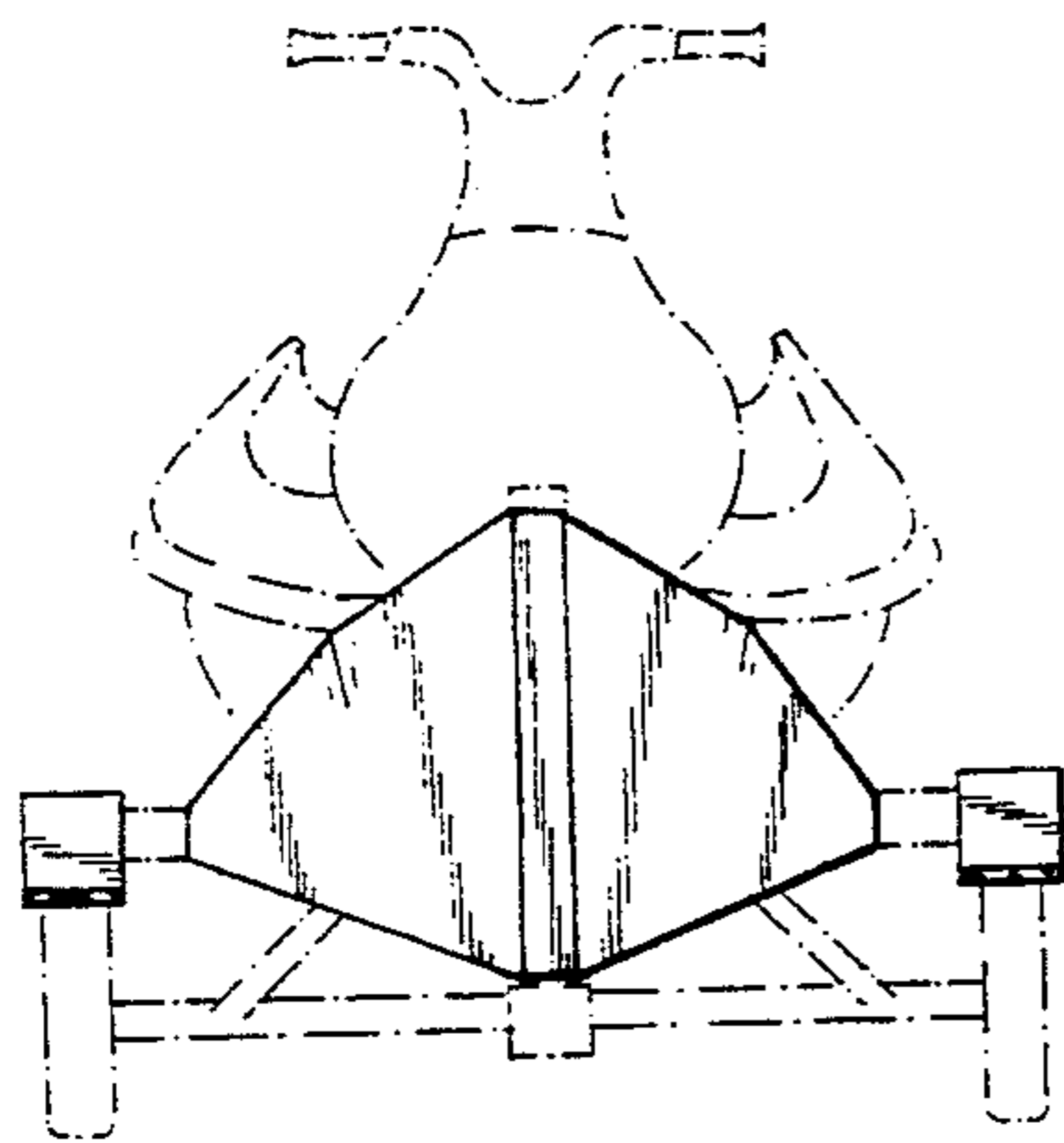

FIG. 2

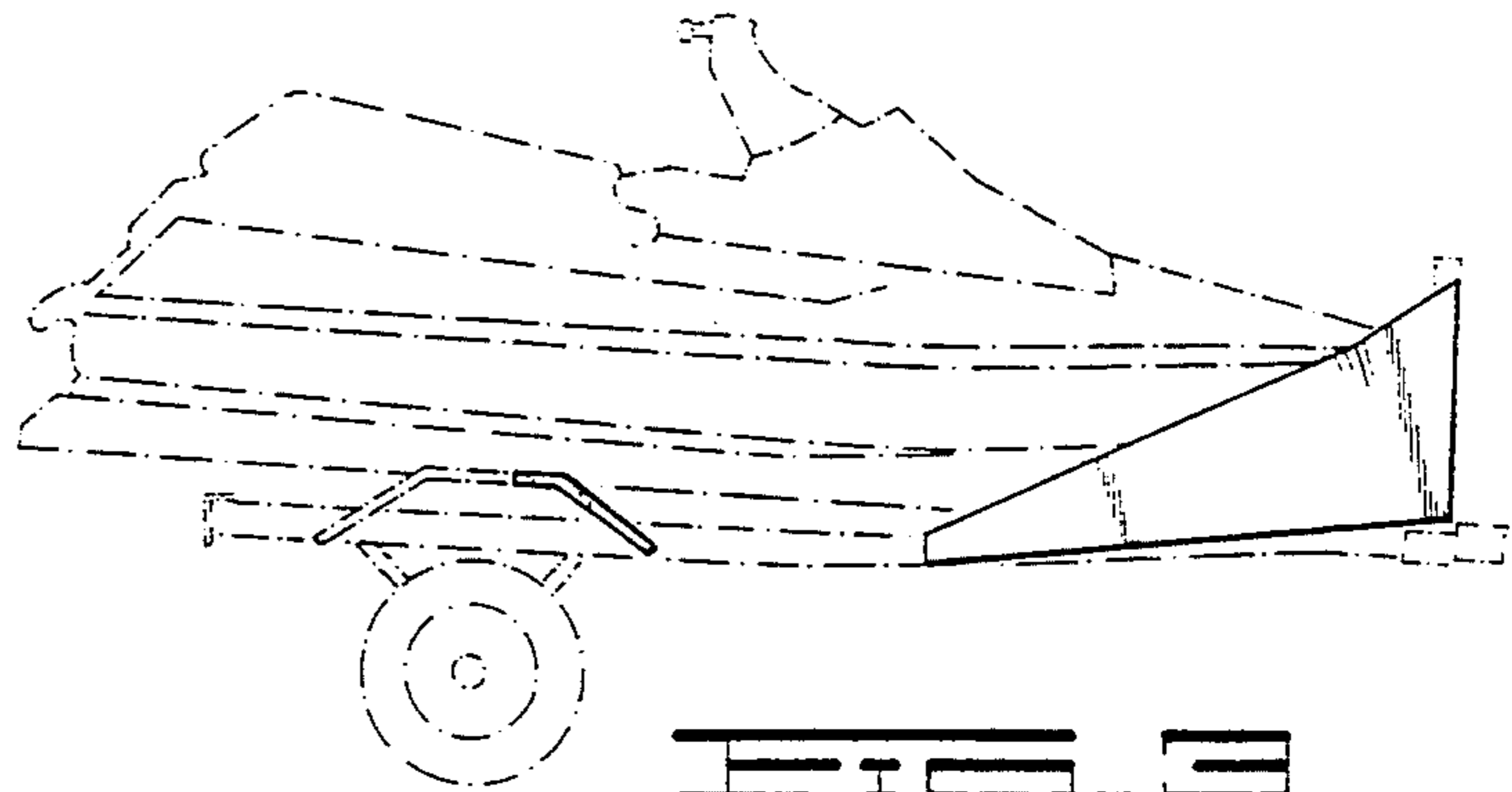

FIG. 3

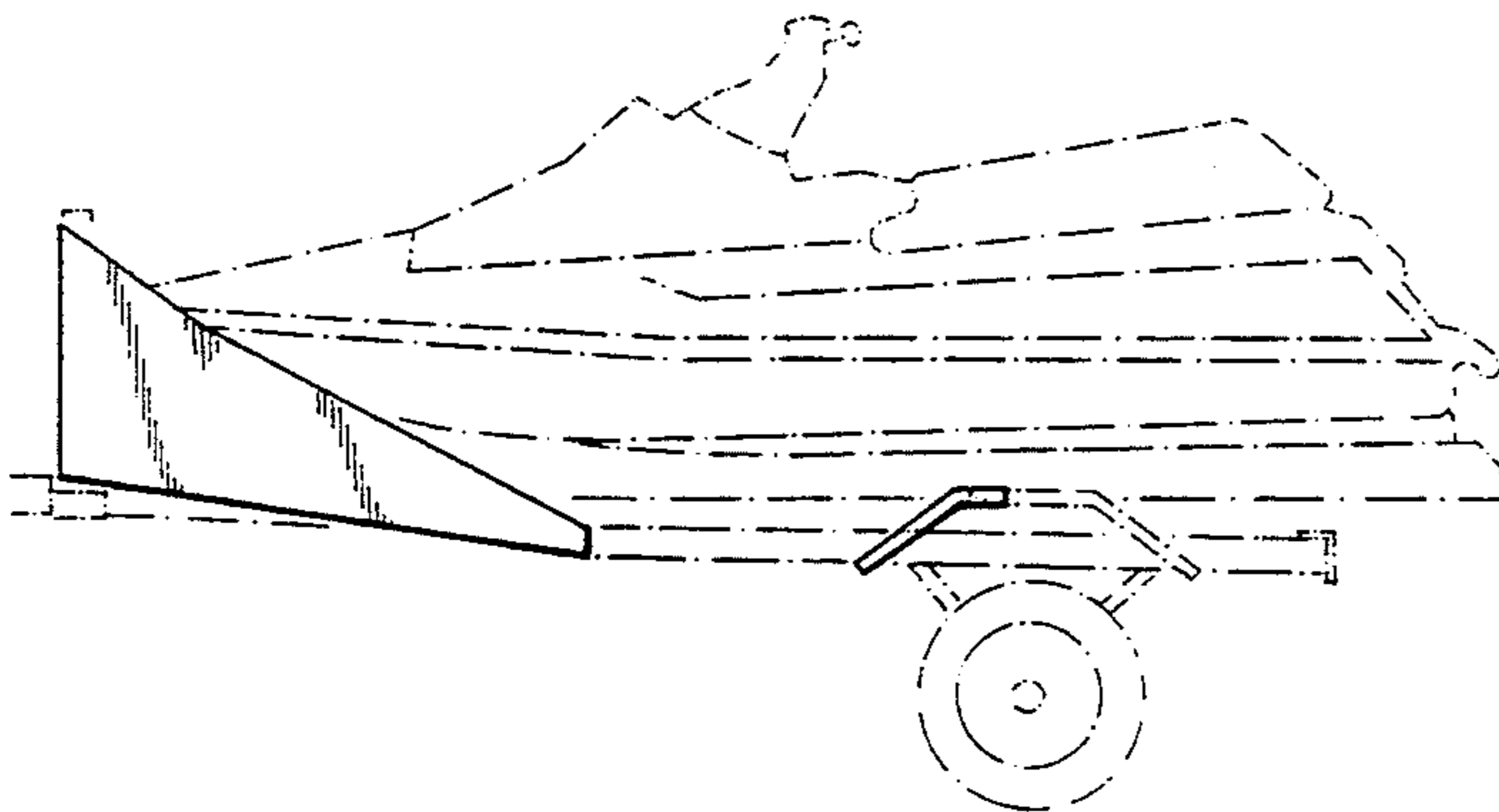

FIG. 4

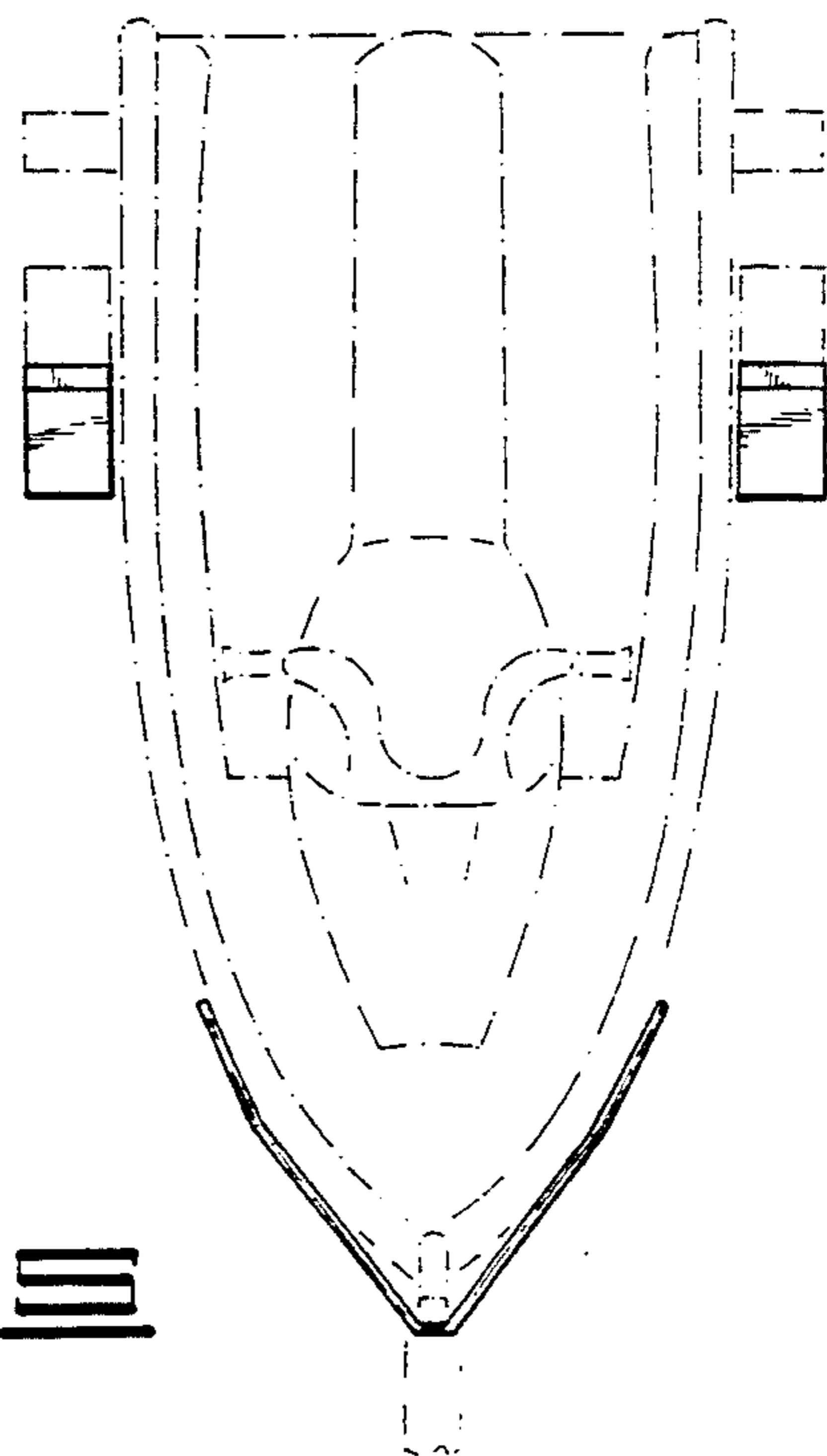

FIG. 5