



US00D356013S

# United States Patent [19]

[11] Patent Number: **Des. 356,013**

**Kiyooka et al.**

[45] Date of Patent: **\*\* Mar. 7, 1995**

[54] **HEDGE TRIMMER**

*Attorney, Agent, or Firm—Keck, Mahin & Cate*

[75] Inventors: **Katsumi Kiyooka, Togane; Masaya Hashimoto, Mobarra; Kaori Katoh, Chiba, all of Japan**

[57] **CLAIM**

The ornamental design for a hedge trimmer, as shown and described.

[73] Assignee: **Maruyama Mfg. Co., Inc., Tokyo, Japan**

### DESCRIPTION

[\*\*] Term: **14 Years**

FIG. 1 is a right side elevational view of a hedge trimmer embodying our design;

[21] Appl. No.: **801,848**

FIG. 2 is a left side elevational view thereof;

[22] Filed: **Dec. 3, 1991**

FIG. 3 is a top plan view thereof;

### [30] Foreign Application Priority Data

FIG. 4 is a bottom plan view thereof;

Jun. 17, 1991 [JP] Japan ..... 3-17719

FIG. 5 is a rear elevational view thereof;

[52] U.S. Cl. .... **D8/8**

FIG. 6 is a front elevational view thereof;

[58] Field of Search ..... **D8/1, 8; D15/10; 30/276; 56/12.7**

FIG. 7 is a right side perspective view thereof;

### [56] References Cited

#### U.S. PATENT DOCUMENTS

D. 285,894	9/1986	Kawakami et al. ....	D8/8
D. 301,961	4/1989	Narisue et al. ....	D8/8
303,973	10/1989	Kiyooka .....	D15/10
D. 308,210	5/1990	Kiyooka .....	D15/10
D. 311,121	10/1990	Pilatowicz et al. ....	D8/8
D. 325,856	5/1992	Gierke .....	D8/8
2,658,273	11/1953	Dodegge .....	D8/8
4,122,601	10/1978	Katsuya .....	30/276 X
4,188,719	2/1980	Hoff .....	56/12.7 X
4,733,471	3/1988	Rahe .....	30/276
4,916,886	4/1990	Nakamura et al. ....	56/12.7
4,976,031	12/1990	Miller .....	30/276

FIG. 8 is a left side perspective view thereof;

FIG. 9 is an enlarged right side elevational view of an engine and handle portion thereof;

FIG. 10 is an enlarged right side elevational view of a blade portion thereof;

FIG. 11 is an enlarged left side elevational view of an engine and handle portion thereof;

FIG. 12 is an enlarged left side elevational view of blade portion thereof;

FIG. 13 is an enlarged top plan view of an engine and handle portion thereof;

FIG. 14 is an enlarged top plan view of a blade portion thereof;

FIG. 15 is an enlarged bottom plan view of an engine and handle portion thereof;

FIG. 16 is an enlarged bottom plan view of a blade portion thereof;

FIG. 17 is an enlarged rear elevational view thereof; and,

FIG. 18 is an enlarged front elevational view thereof.

*Primary Examiner—Wallace R. Burke*  
*Assistant Examiner—H Baynham*

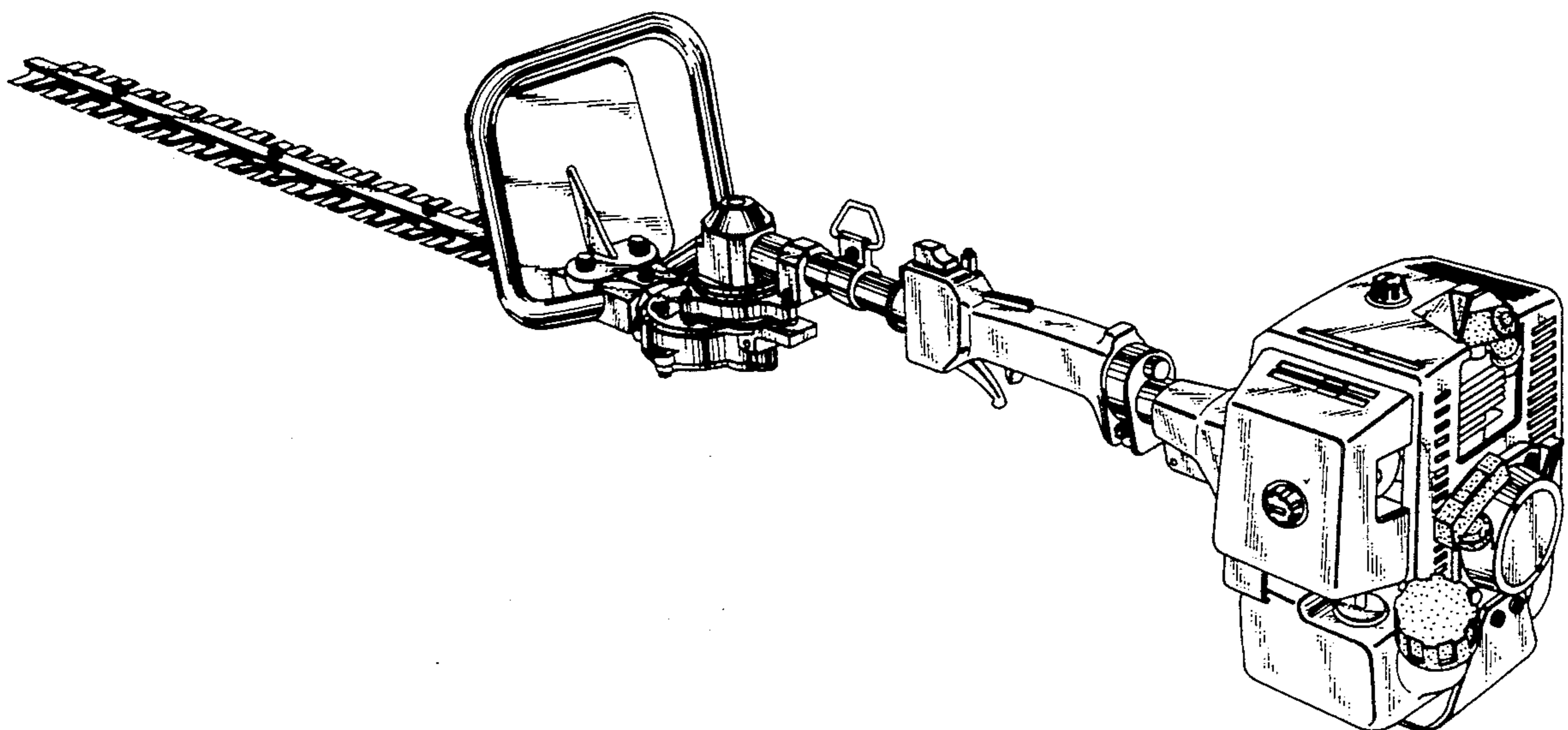

FIG. 1

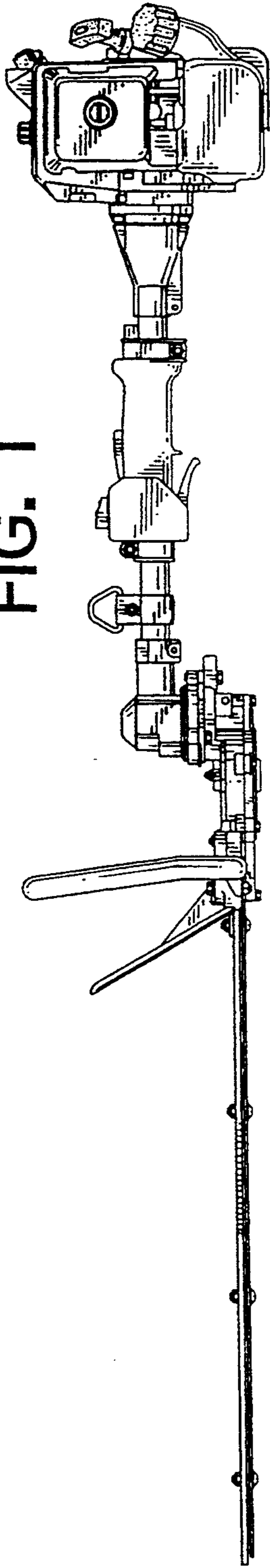

FIG. 3

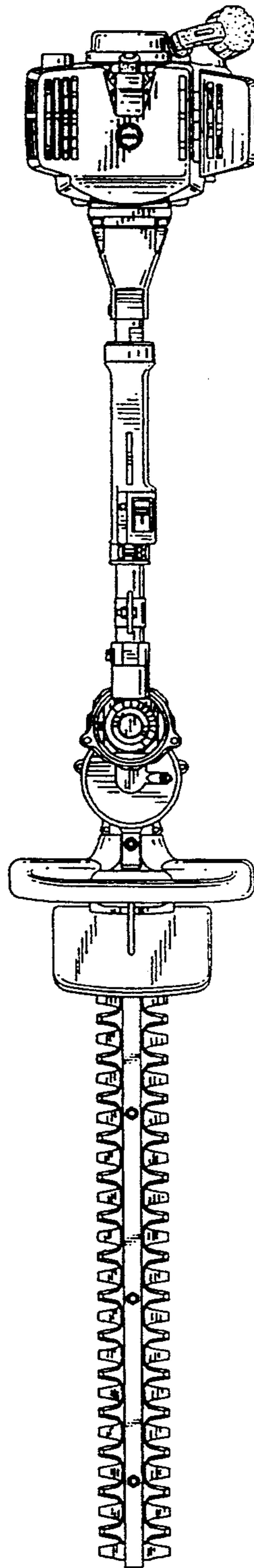

FIG. 4

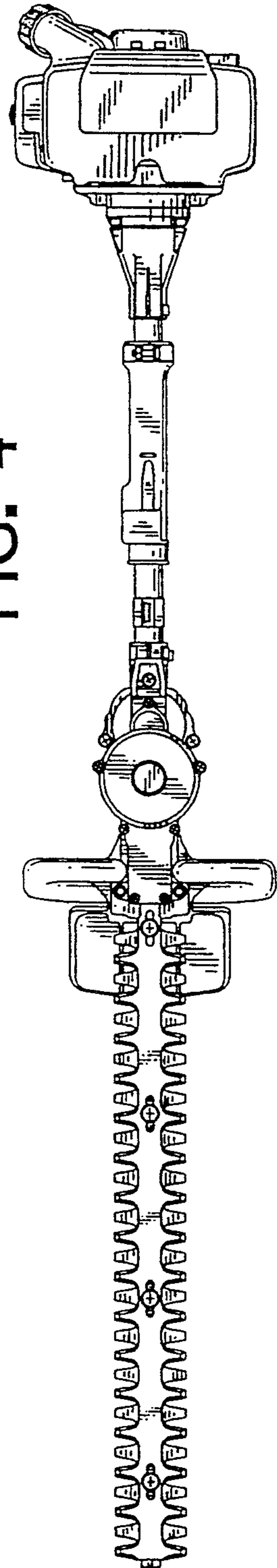

FIG. 2

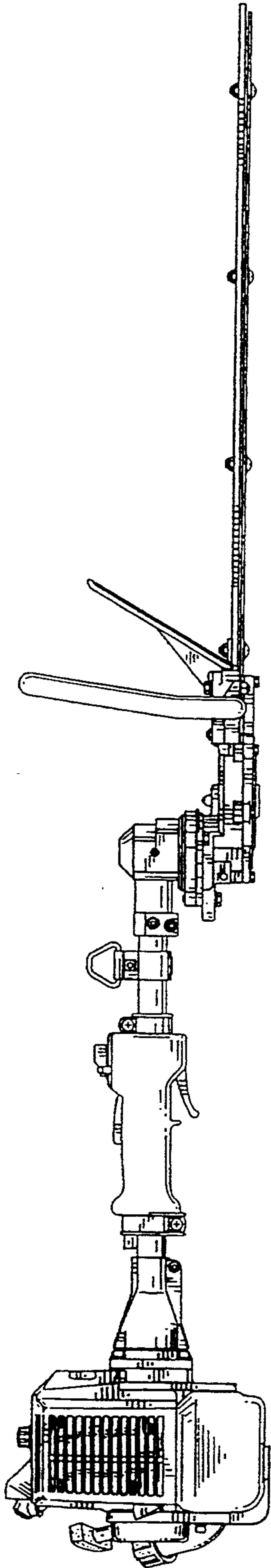

FIG. 5

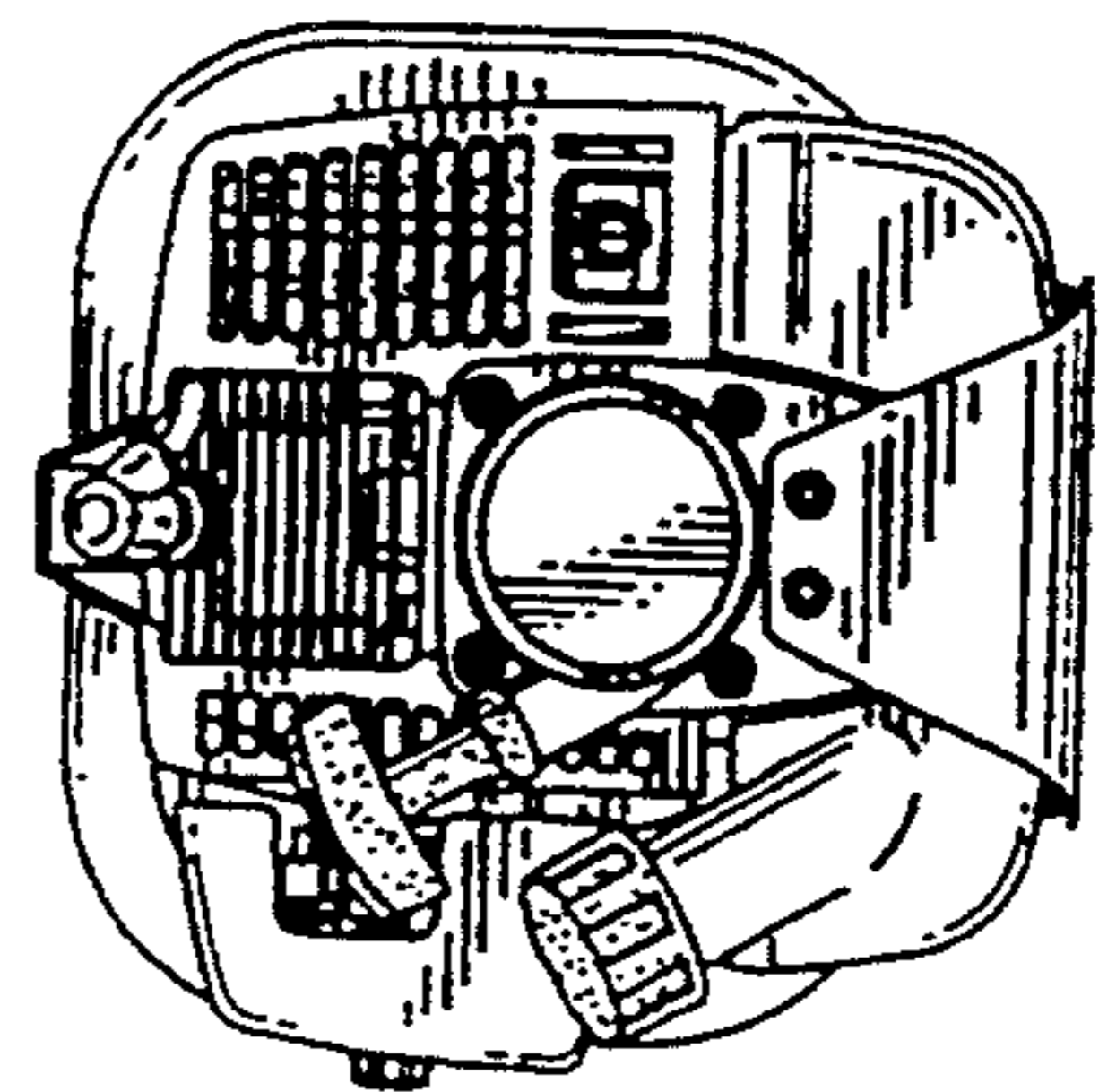

FIG. 6

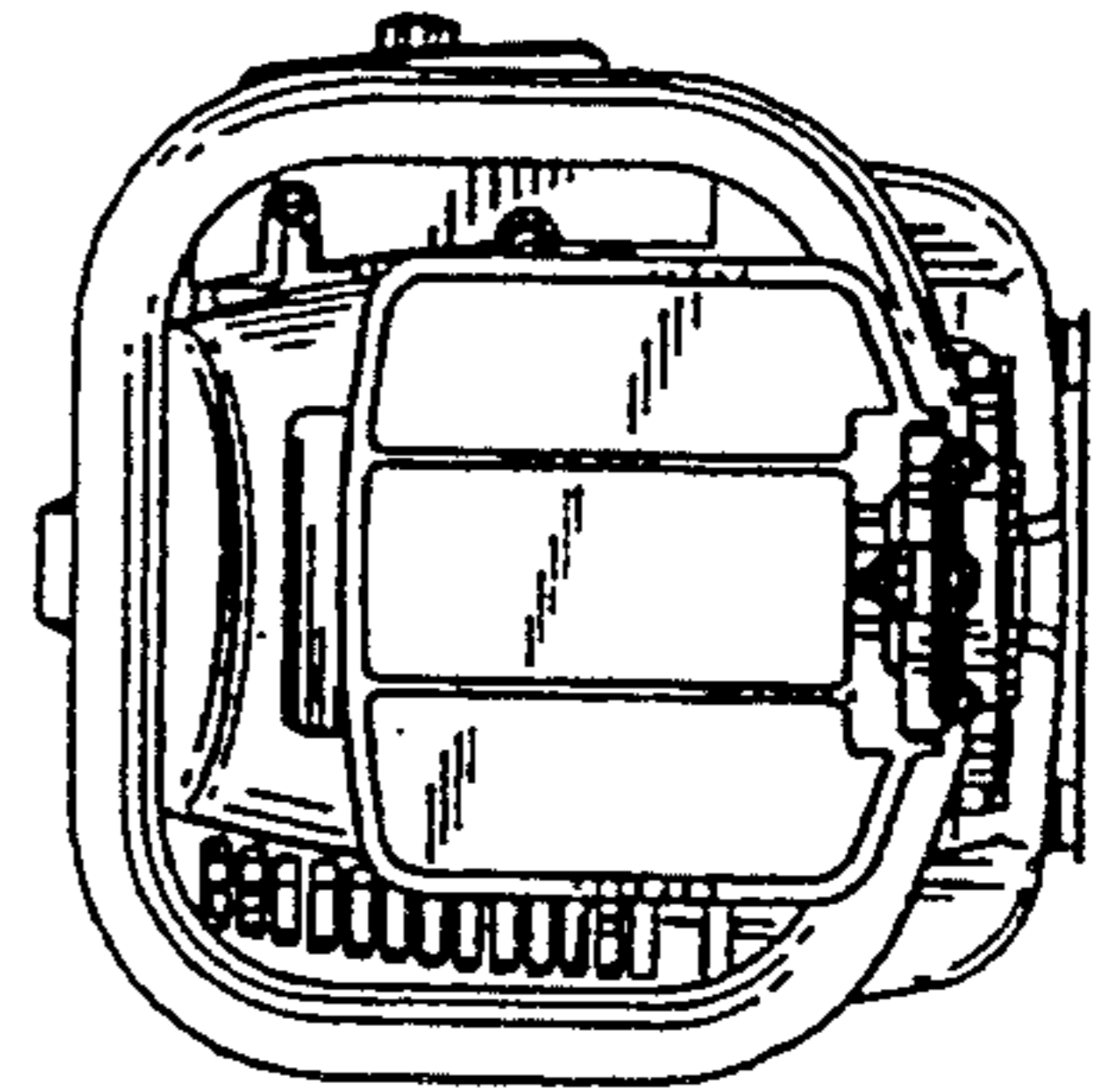

FIG. 7

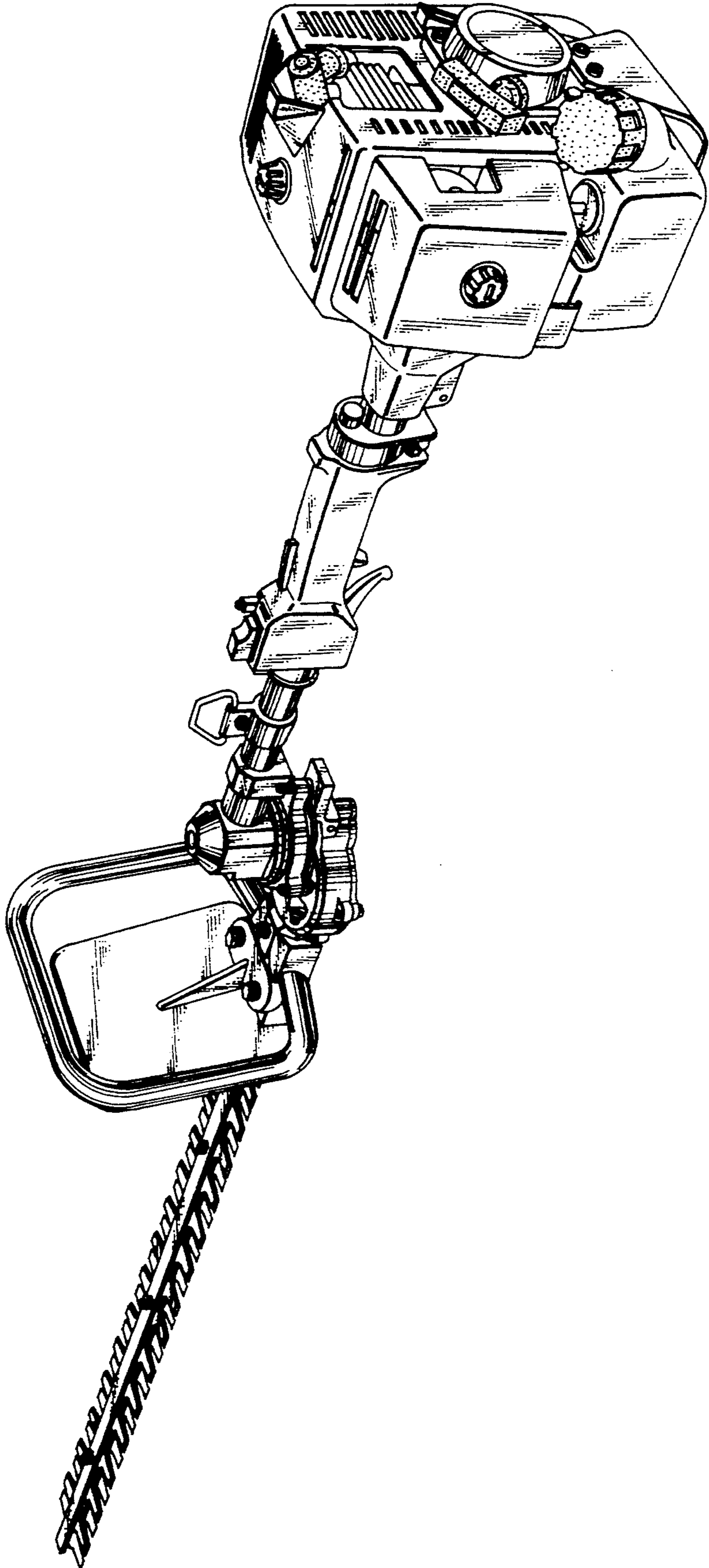

FIG. 8

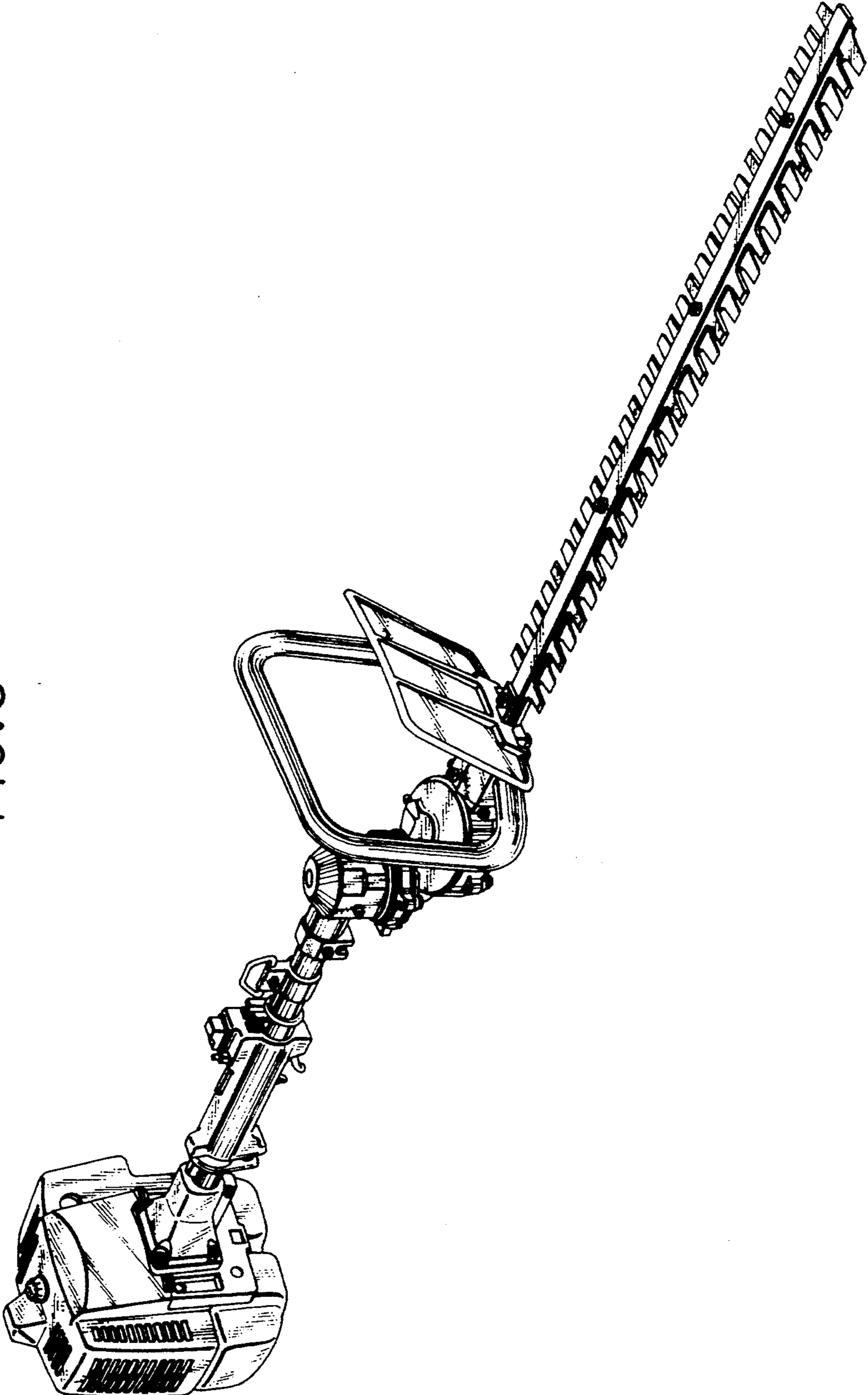

FIG. 9

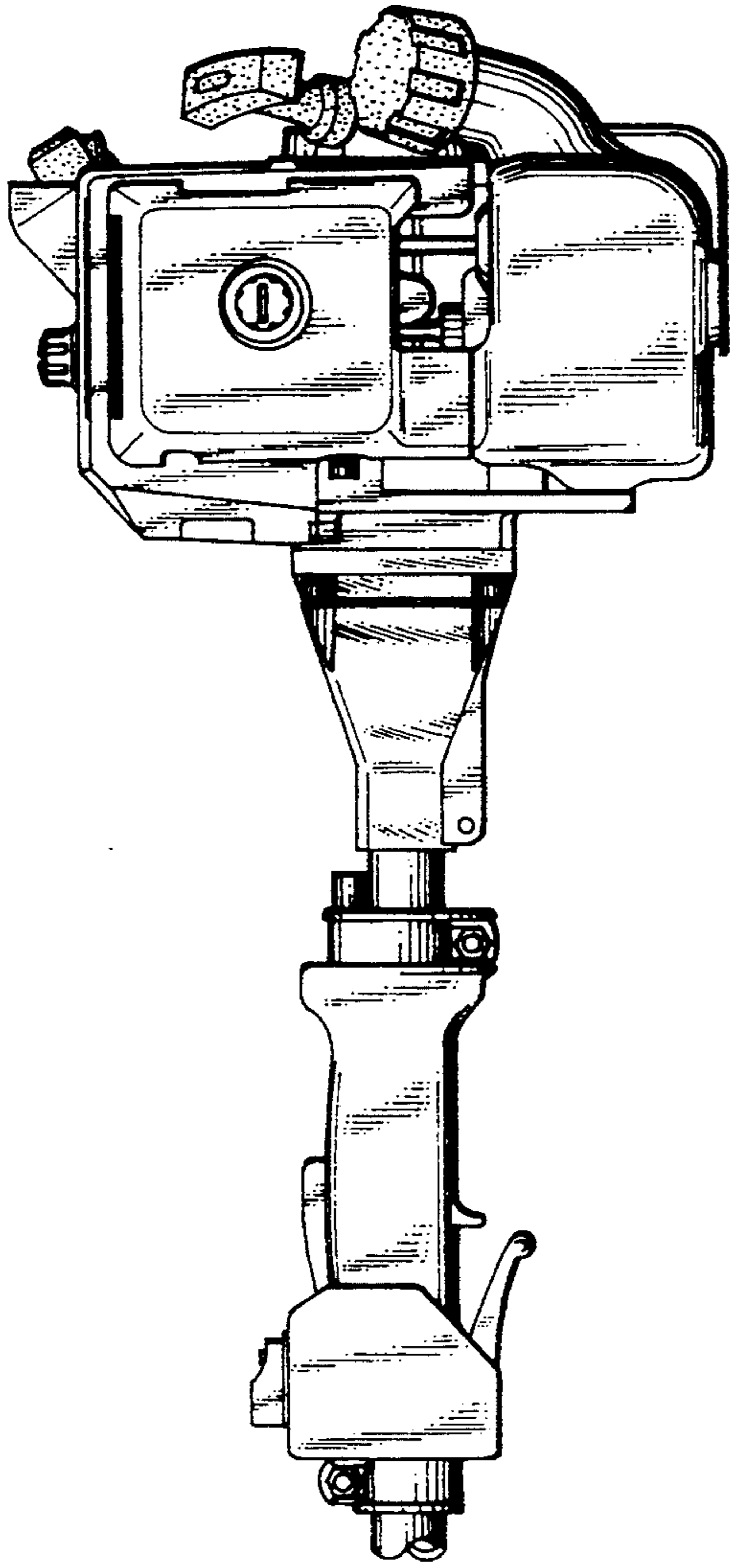

FIG. 10

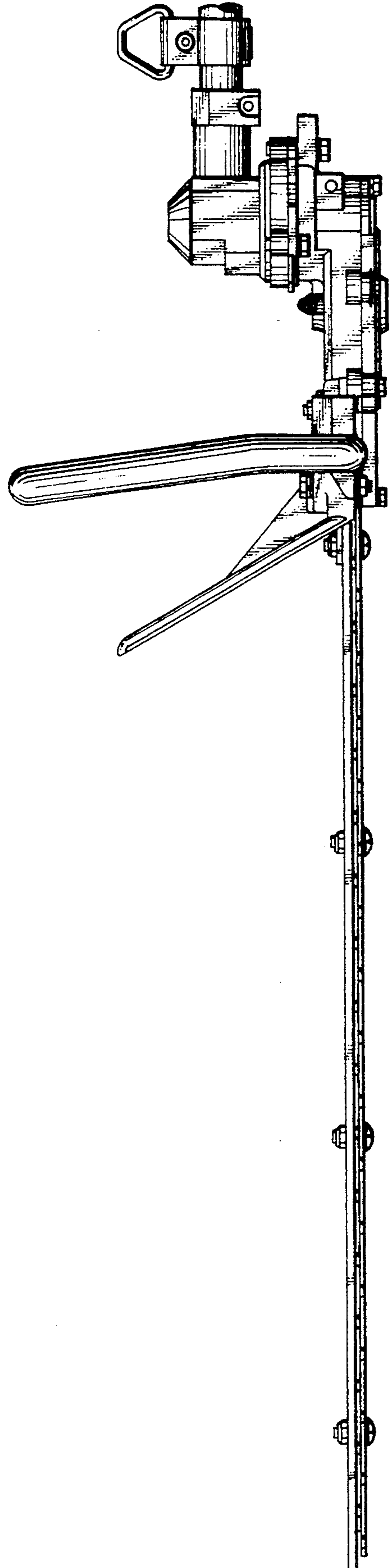

FIG.11

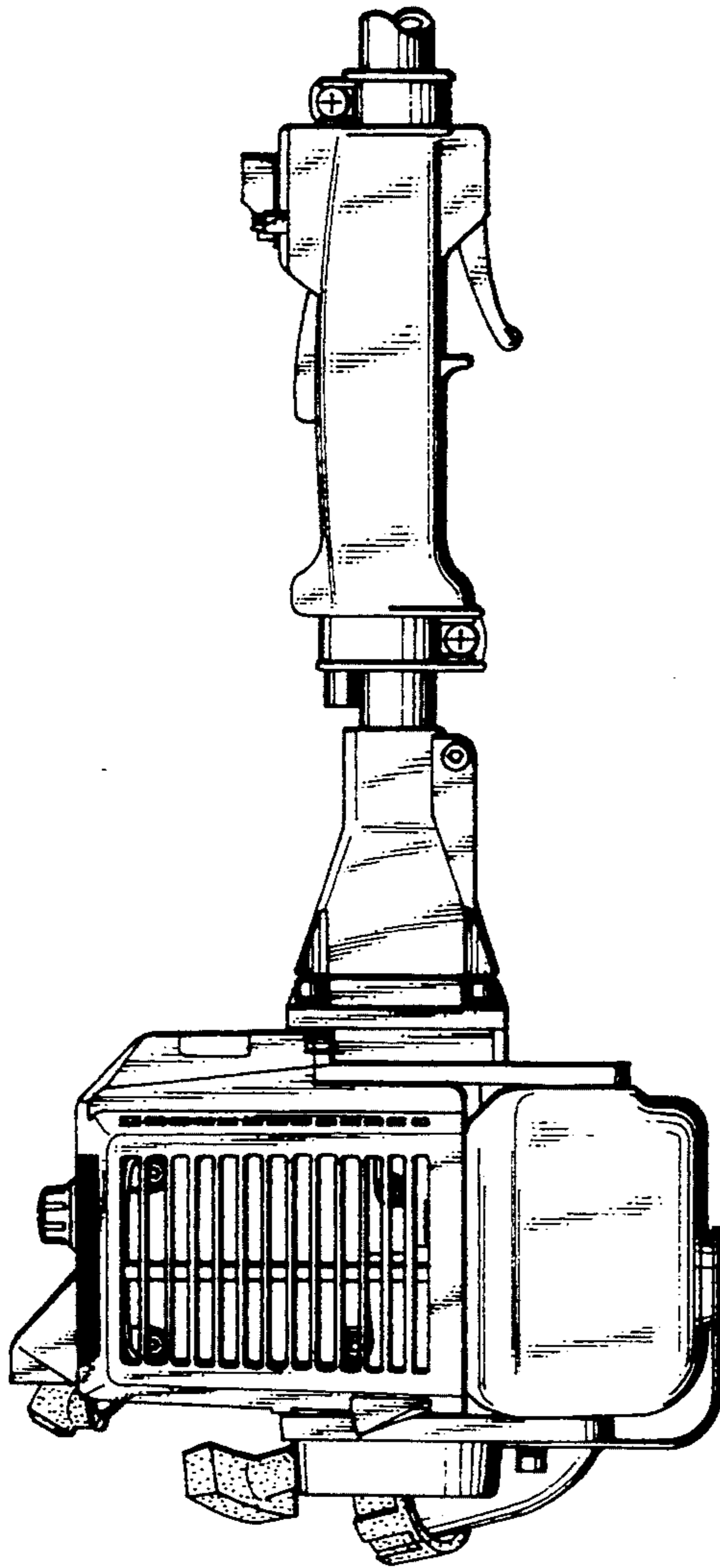

FIG.12

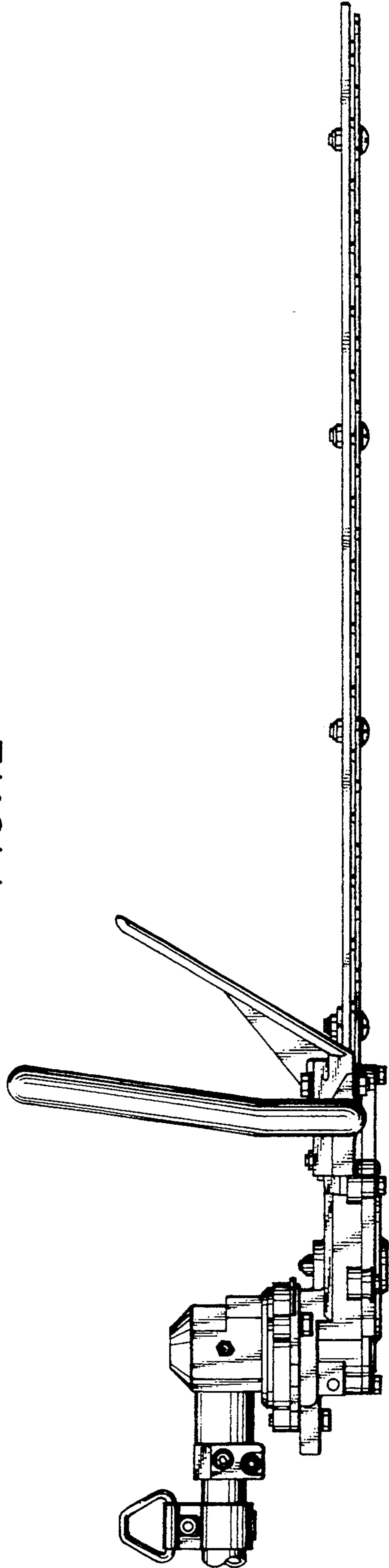

FIG. 13

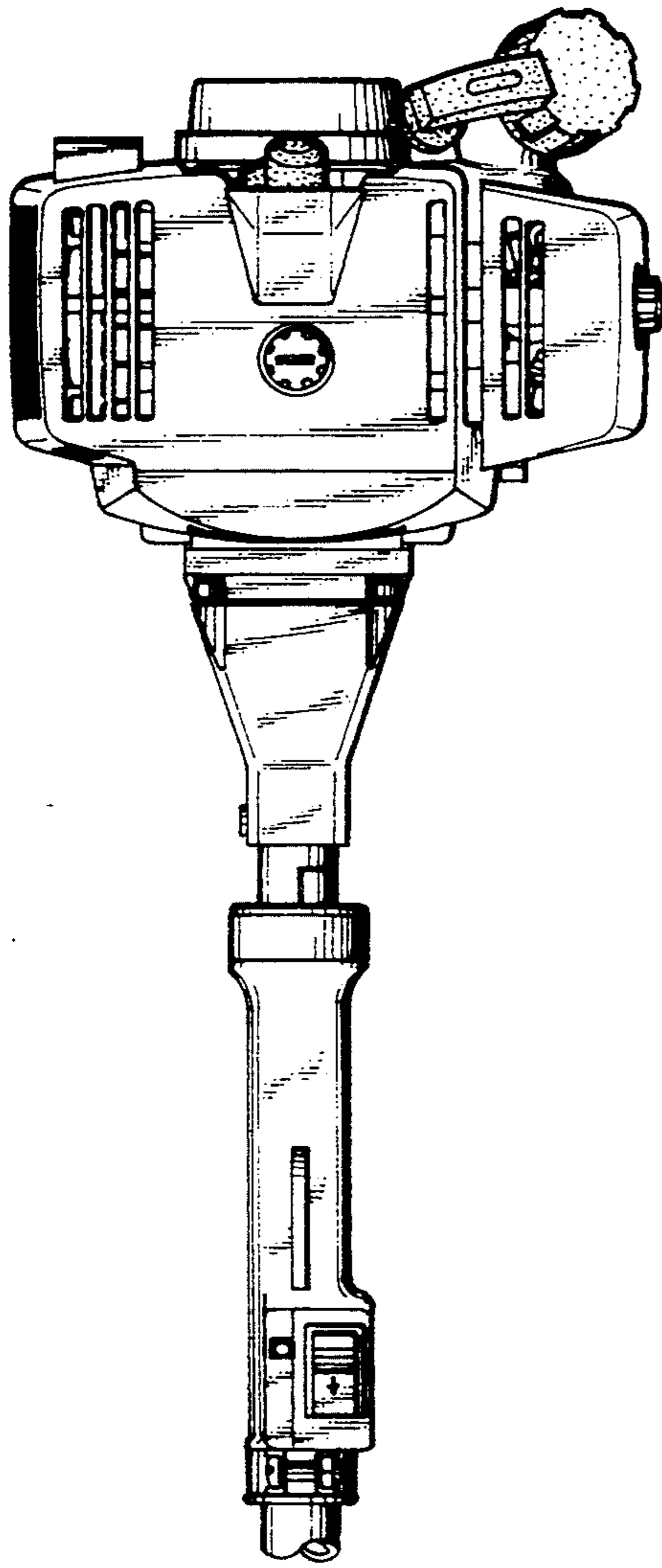

FIG. 14

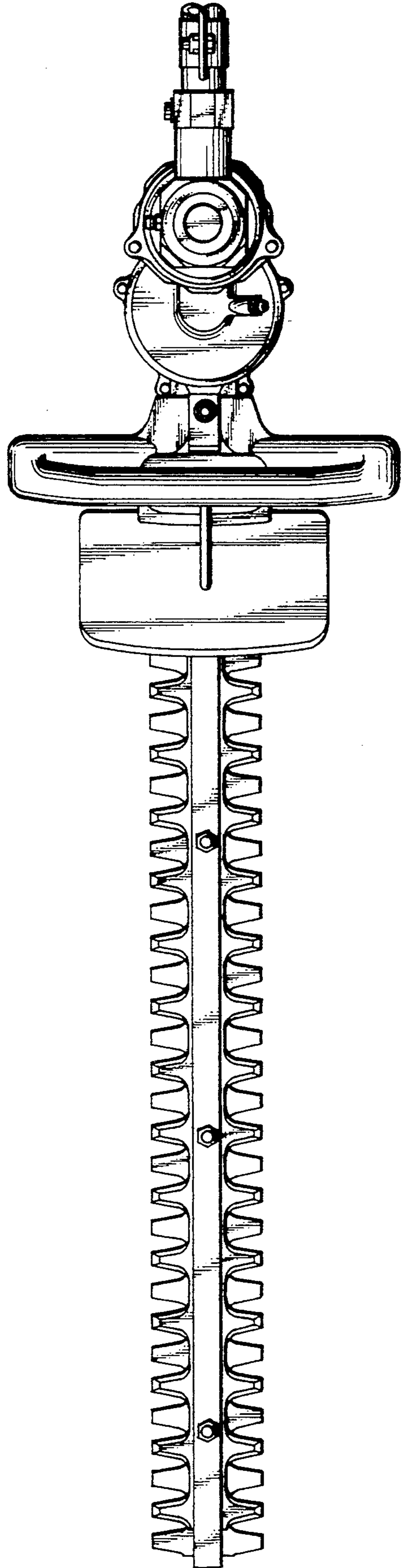



FIG. 15

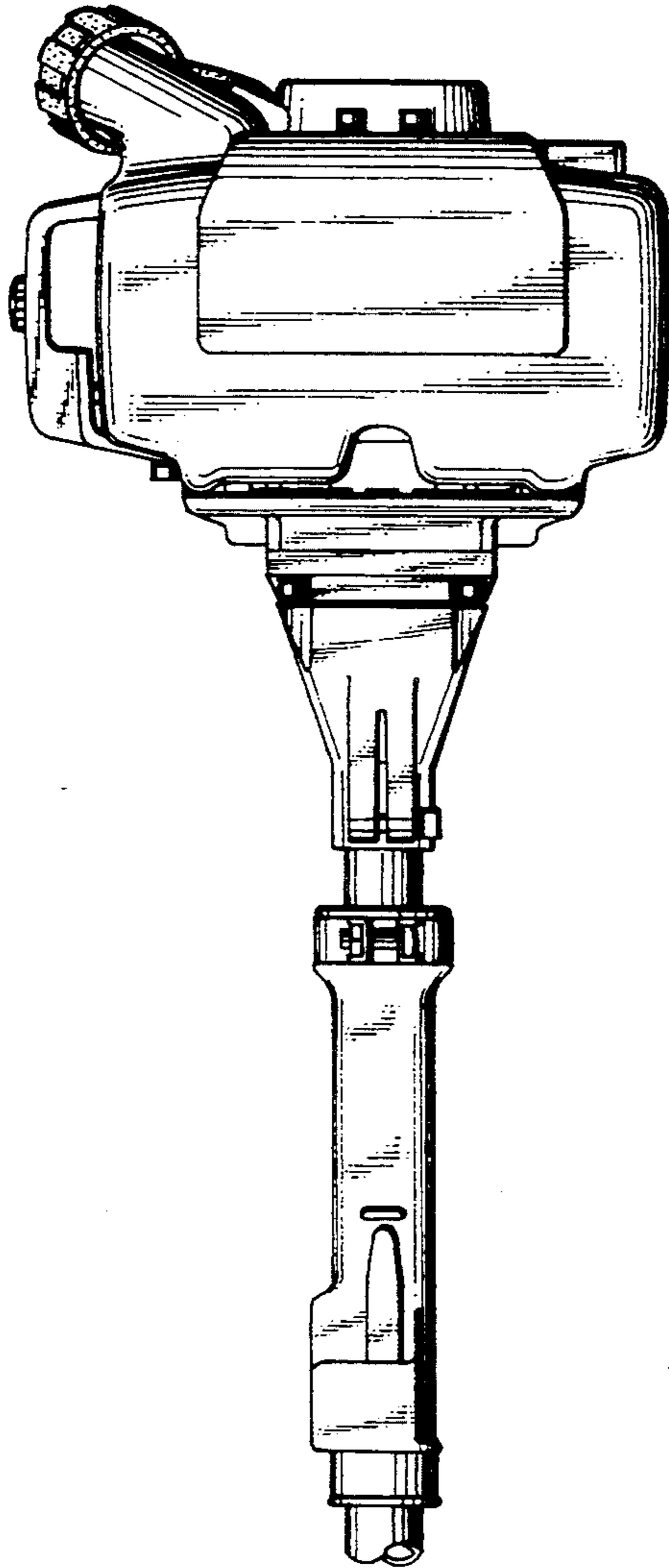

FIG. 16

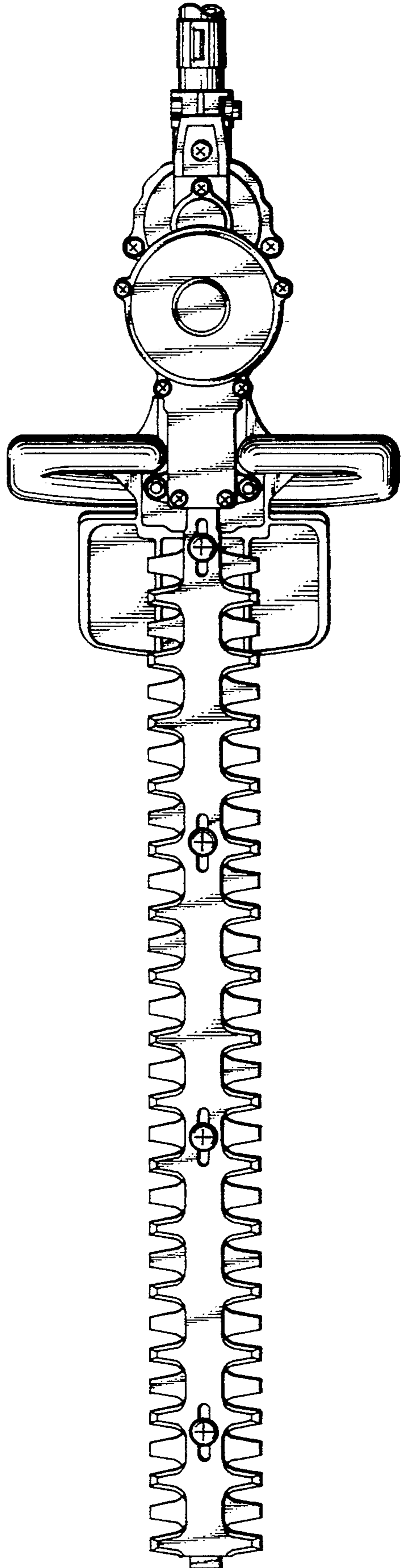

FIG.17

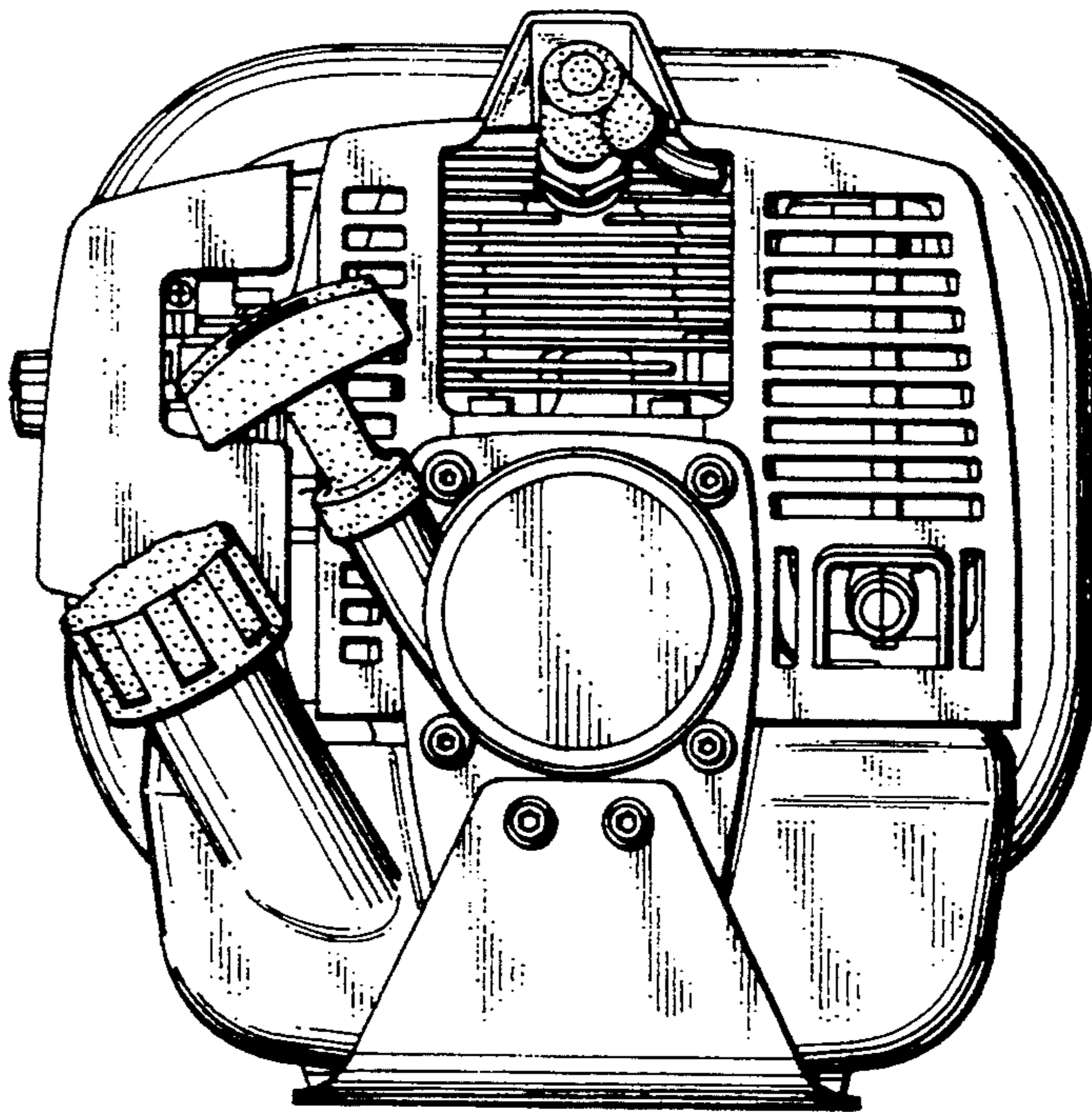

FIG.18

