



US00D355884S

United States Patent [19]

[11] Patent Number: **Des. 355,884**

Schlangen et al.

[45] Date of Patent: **** Feb. 28, 1995**

- [54] **CHAIN GUARD FOR PERSONALIZED WATERCRAFT**
- [75] Inventors: **Phillip E. Schlangen; Raymond J. Buresch**, both of Minneapolis, Minn.
- [73] Assignee: **Hydro-Bikes, Inc.**, Minneapolis, Minn.
- [**] Term: **14 Years**
- [21] Appl. No.: **14,220**
- [22] Filed: **Oct. 18, 1993**
- [52] U.S. Cl. **D12/317; D12/127**
- [58] Field of Search **D12/317, 306, 127, 126; 114/270, 61; 474/144, 145, 146, 147**

- 1,695,304 12/1928 Turner .
- 2,177,074 10/1939 Mattson .
- 3,352,276 11/1967 Zimmerman .
- 3,375,022 3/1968 Hattan .
- 4,021,873 5/1977 Francois .
- 4,323,352 4/1982 Warren et al. .
- 4,968,274 11/1990 Gregory .

Primary Examiner—Kay H. Chin

[57] CLAIM

The ornamental design for a chain guard for personalized watercraft, as shown and described.

DESCRIPTION

FIG. 1 is a front elevational view of the chain guard for personalized watercraft showing our new design;
 FIG. 2 is a bottom plan view thereof;
 FIG. 3 is a top plan view thereof;
 FIG. 4 is a rear elevational view thereof;
 FIG. 5 is a front end elevational view thereof; and,
 FIG. 6 is a rear end elevational view thereof.

- [56] **References Cited**
- U.S. PATENT DOCUMENTS**
- D. 163,169 5/1951 Daugherty D12/126
- D. 251,186 2/1979 Patterson et al. D12/127

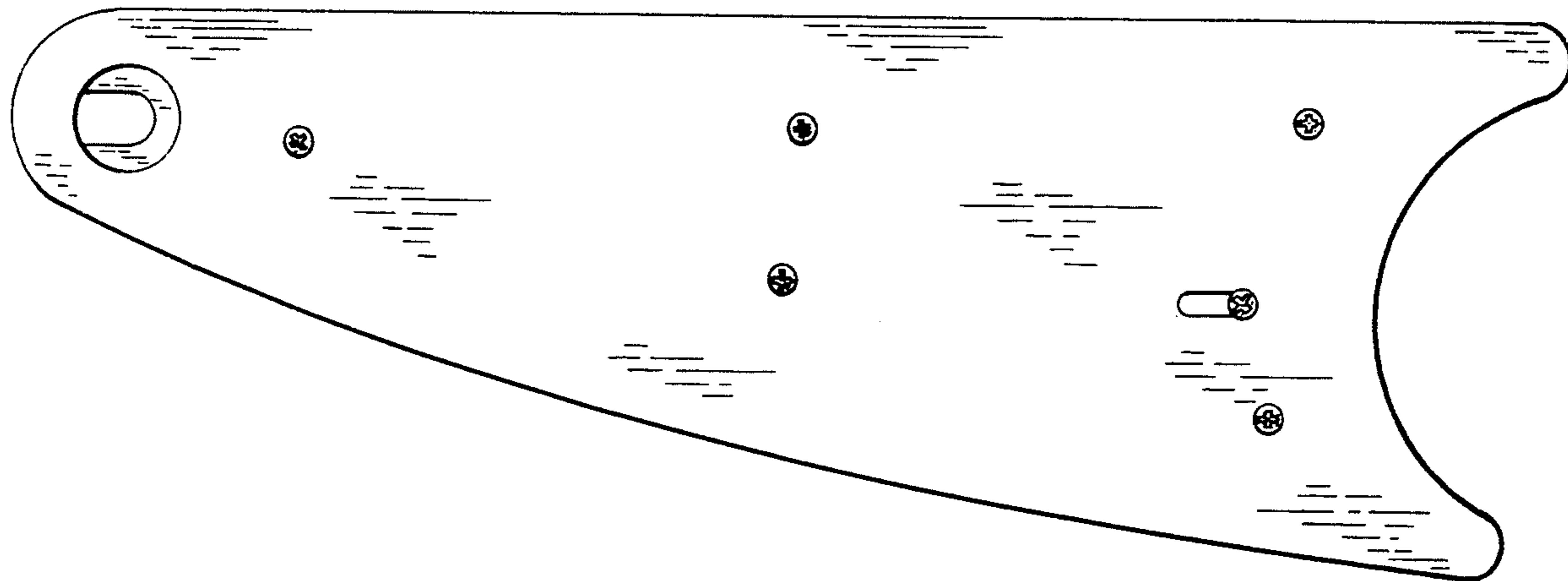

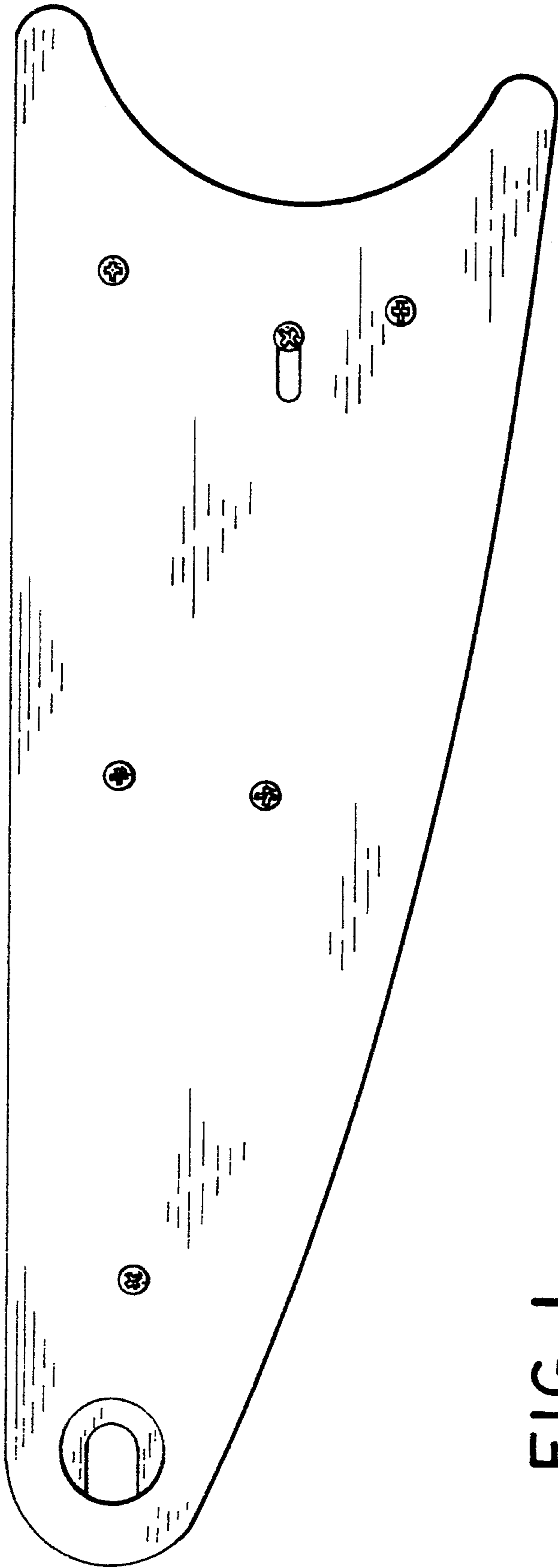

FIG. 1

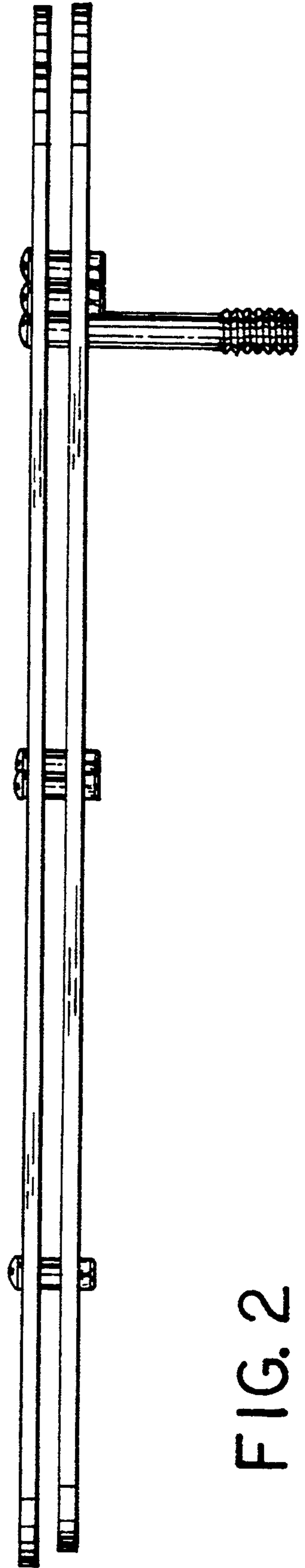

FIG. 2

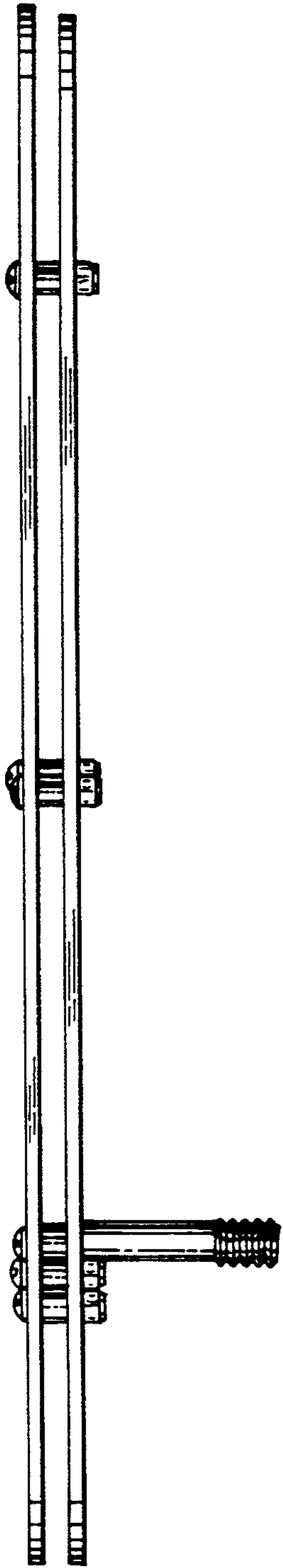

FIG. 3

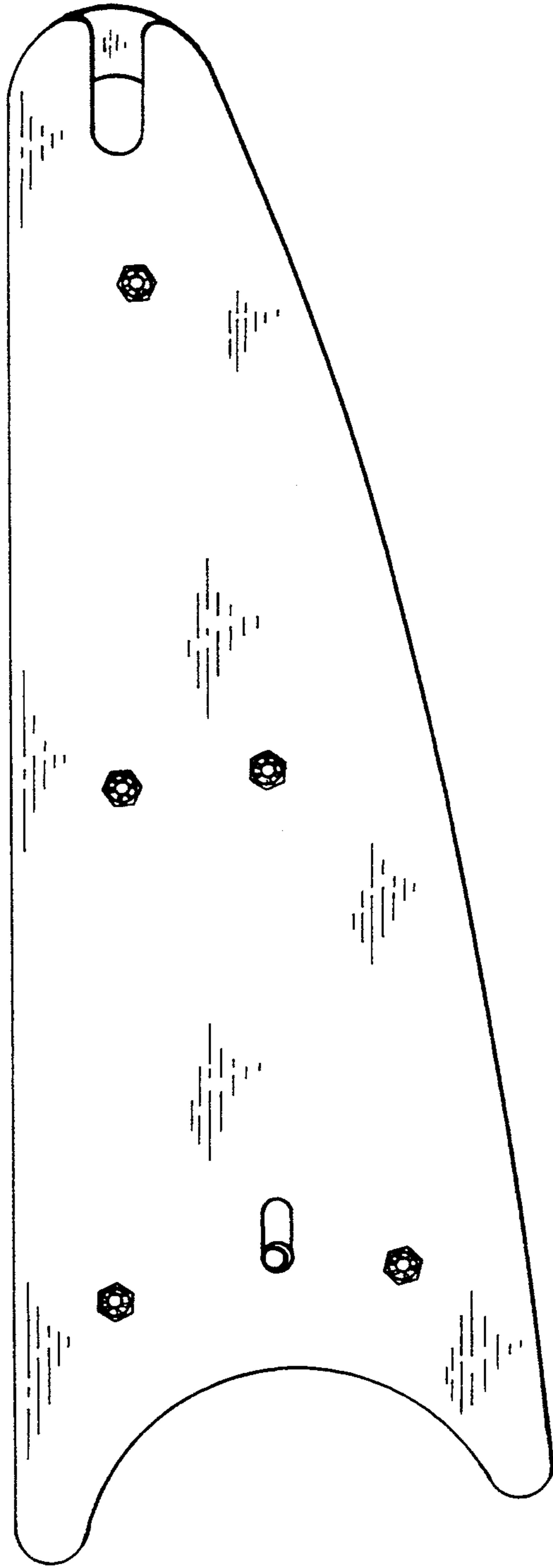

FIG. 4

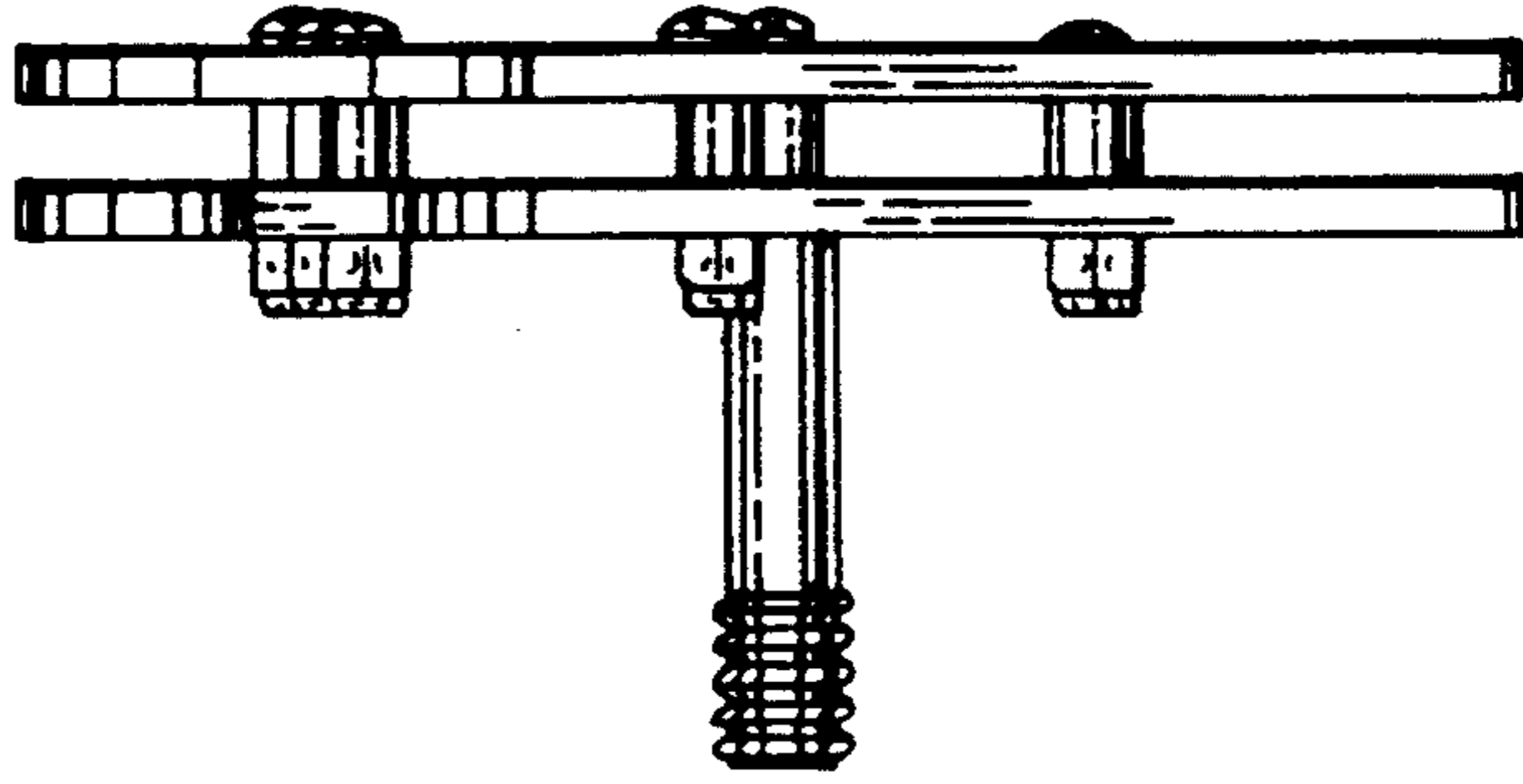

FIG. 6

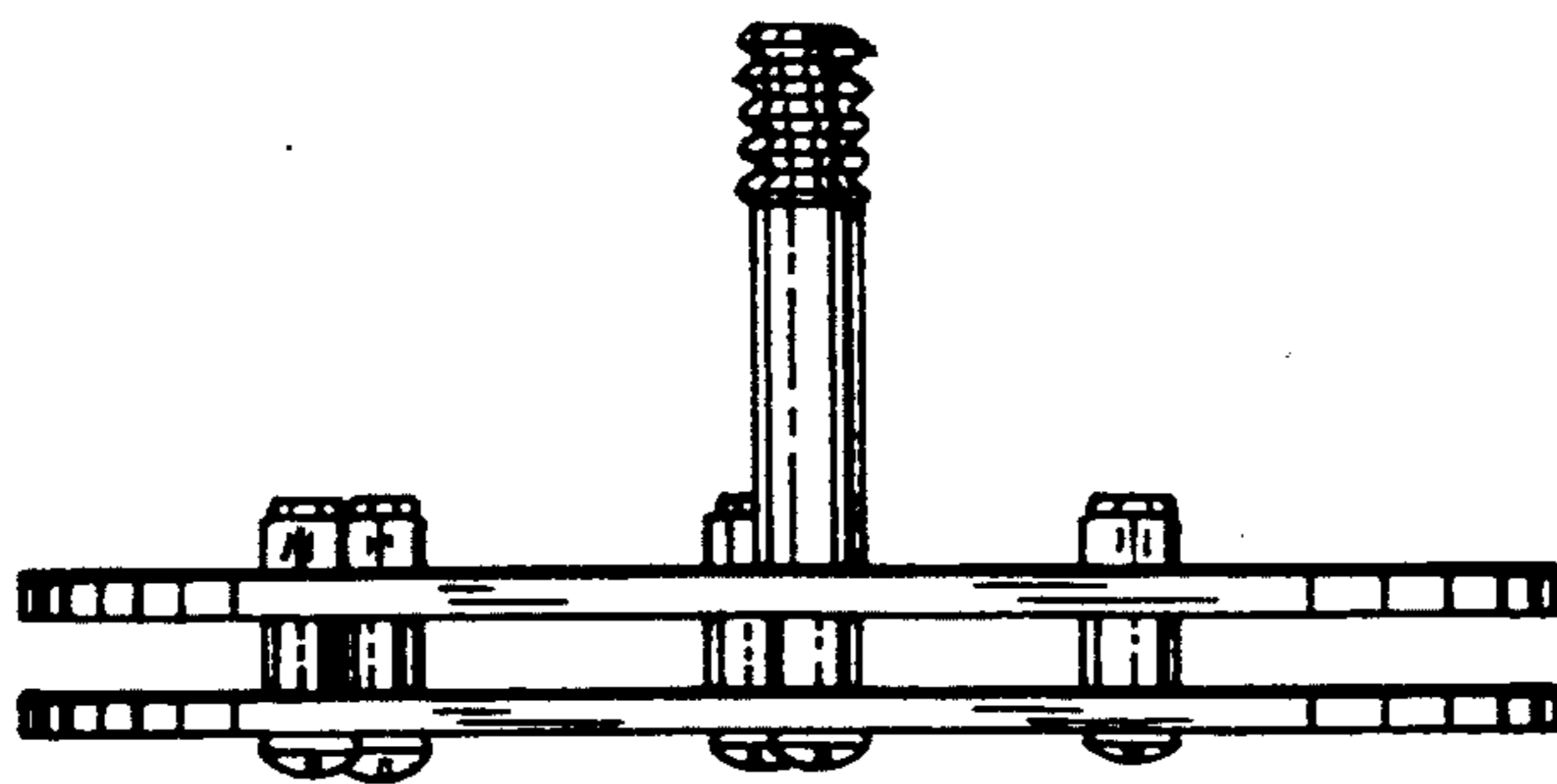

FIG. 5