



US00D355879S

United States Patent [19] Winblad

[11] Patent Number: **Des. 355,879**
[45] Date of Patent: **** Feb. 28, 1995**

- [54] **STEERING WHEEL CONFIGURATION**
- [75] Inventor: **Wade O. Winblad, Hayward, Calif.**
- [73] Assignee: **Atari Games Corporation, Milpitas, Calif.**
- [**] Term: **14 Years**
- [21] Appl. No.: **1,833**
- [22] Filed: **Nov. 20, 1992**

4,713,007	12/1987	Alban	434/46
4,716,458	12/1987	Heitzman et al.	358/103
4,728,122	3/1988	Wright	74/608
4,750,888	6/1988	Allard et al.	434/46
4,940,234	7/1990	Ishida et al.	273/1 GA
4,960,117	10/1990	Moncrief et al.	273/148 B
5,044,956	9/1991	Behensky et al.	434/45

Related U.S. Application Data

- [63] Continuation-in-part of Ser. No. 888,375, May 22, 1992.
- [52] U.S. Cl. **D12/176**
- [58] Field of Search **D12/176, 175; D21/48; 74/552, 608; 434/69**

OTHER PUBLICATIONS

Atari Games Corporation, "Hard Drivin" brochure, 1988.
Atari Games Corporation, "Hard Drivin" Operator's Manual, 1989, pp. ii, 1-4, and 1-5.

Primary Examiner—Wallace R. Burke
Assistant Examiner—M. Brown
Attorney, Agent, or Firm—Knobbe, Martens, Olson & Bear

[56] References Cited

U.S. PATENT DOCUMENTS

D. 114,266	4/1939	Hoover	D12/176
D. 167,604	9/1952	Baldwin	D12/176
D. 241,133	8/1976	Gonzalez	D12/176
D. 245,839	9/1977	Spurgen	D12/176
D. 321,497	11/1991	Whitley, II	D12/176
D. 326,253	5/1992	Frietze	D12/176
3,193,946	7/1965	Patuano	35/11 R
3,936,955	2/1976	Gruen et al.	35/11 R
4,044,624	8/1977	Dekker	74/552
4,208,833	6/1980	Wolf	46/240
4,650,438	3/1987	Ajiro	446/136

CLAIM

The ornamental design for a steering wheel configuration, as shown.

DESCRIPTION

FIG. 1 is a front perspective view of my new steering wheel configuration;
FIG. 2 is a front elevational view thereof;
FIG. 3 is a right, side elevational view thereof;
FIG. 4 is a left, side elevational view thereof;
FIG. 5 is a top plan view thereof;
FIG. 6 is a bottom plan view thereof; and,
FIG. 7 is a rear view thereof.

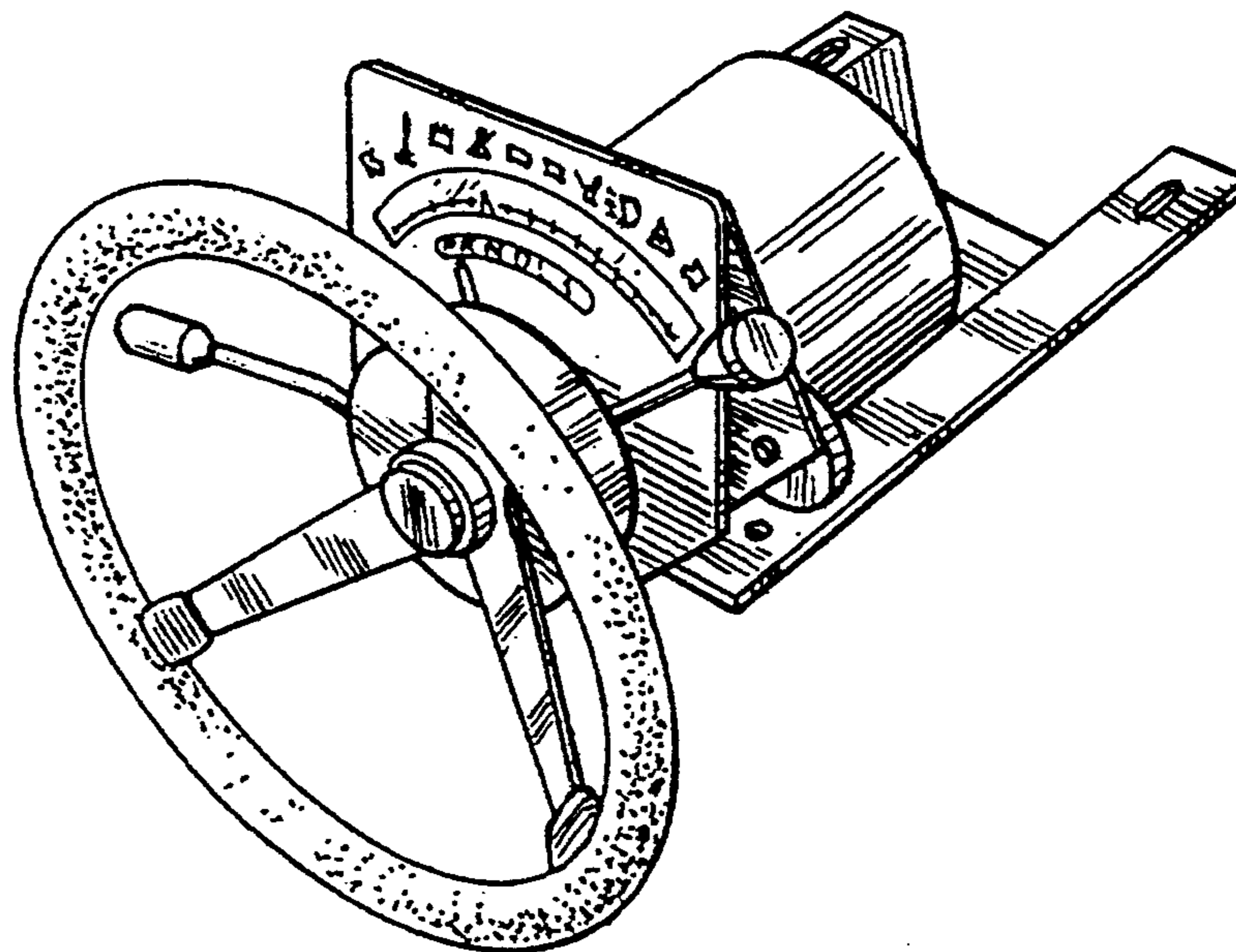

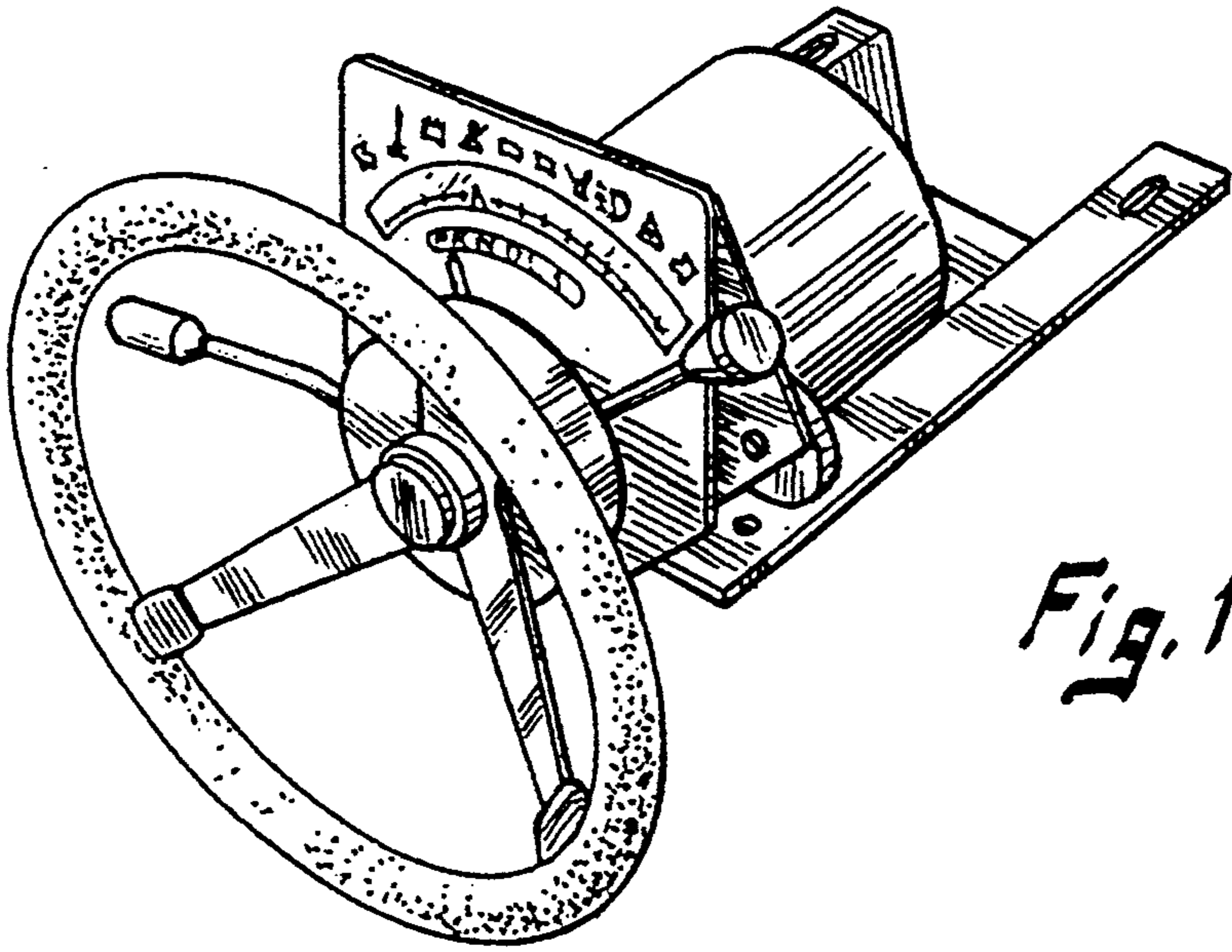

Fig. 1

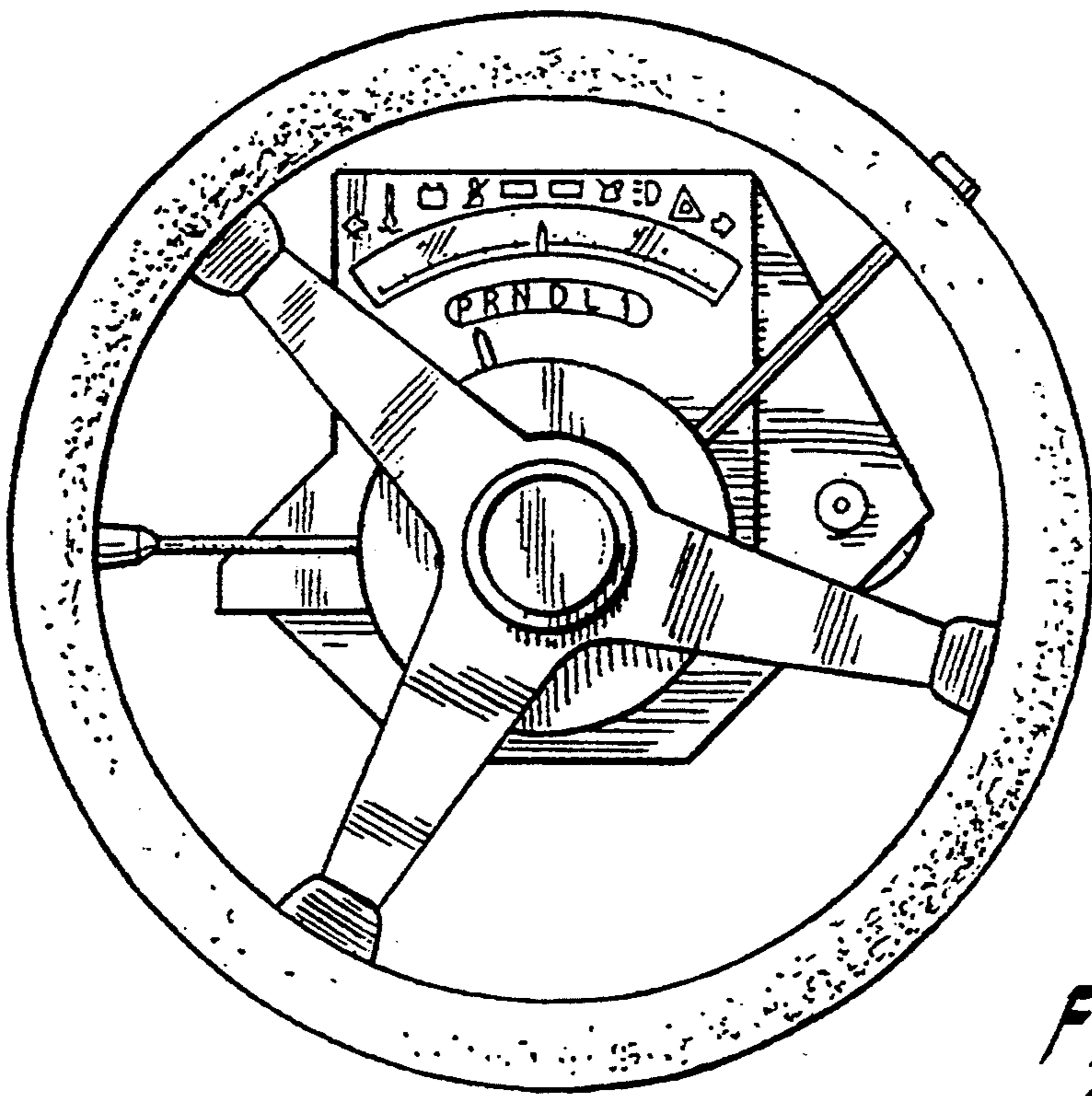
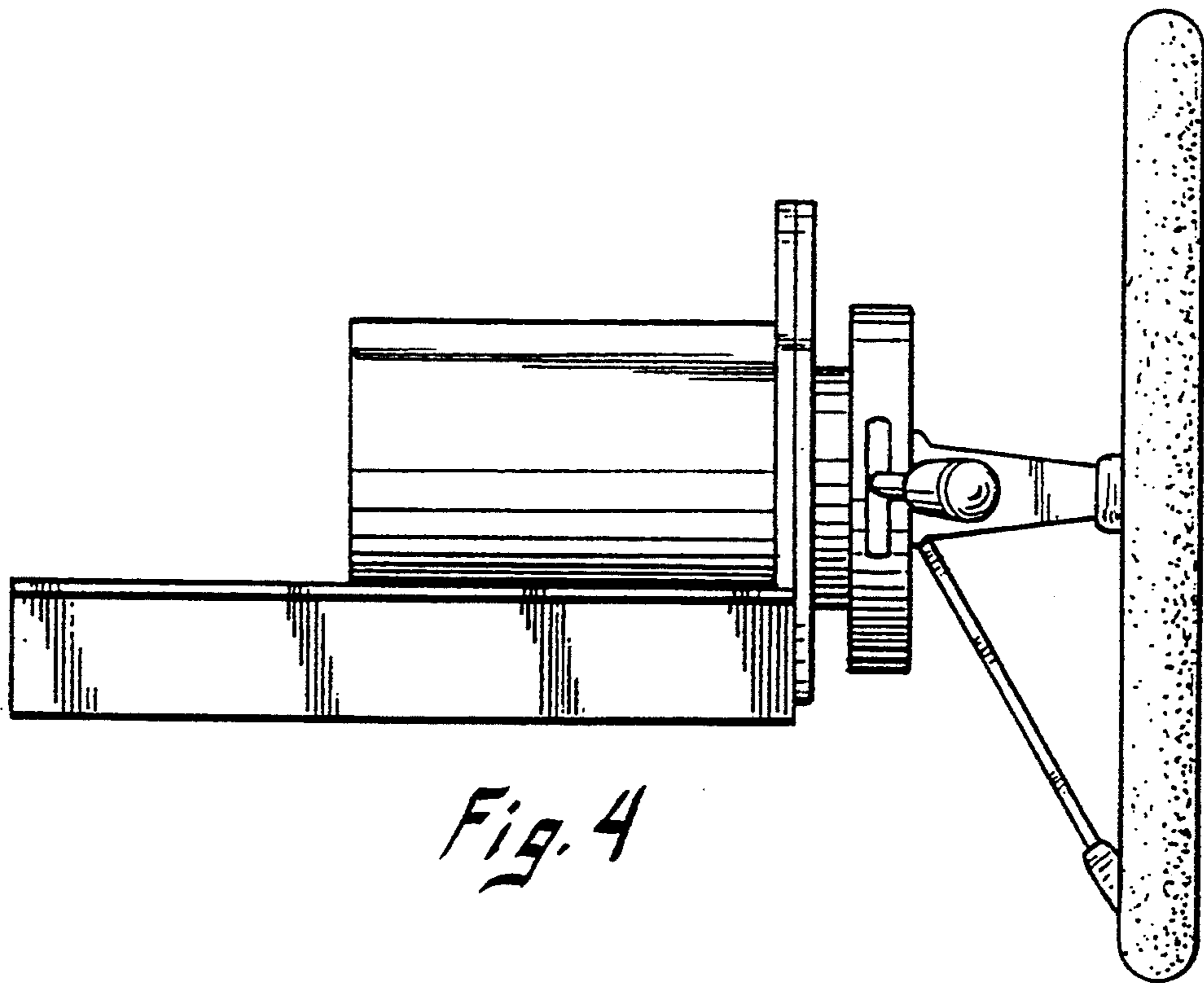
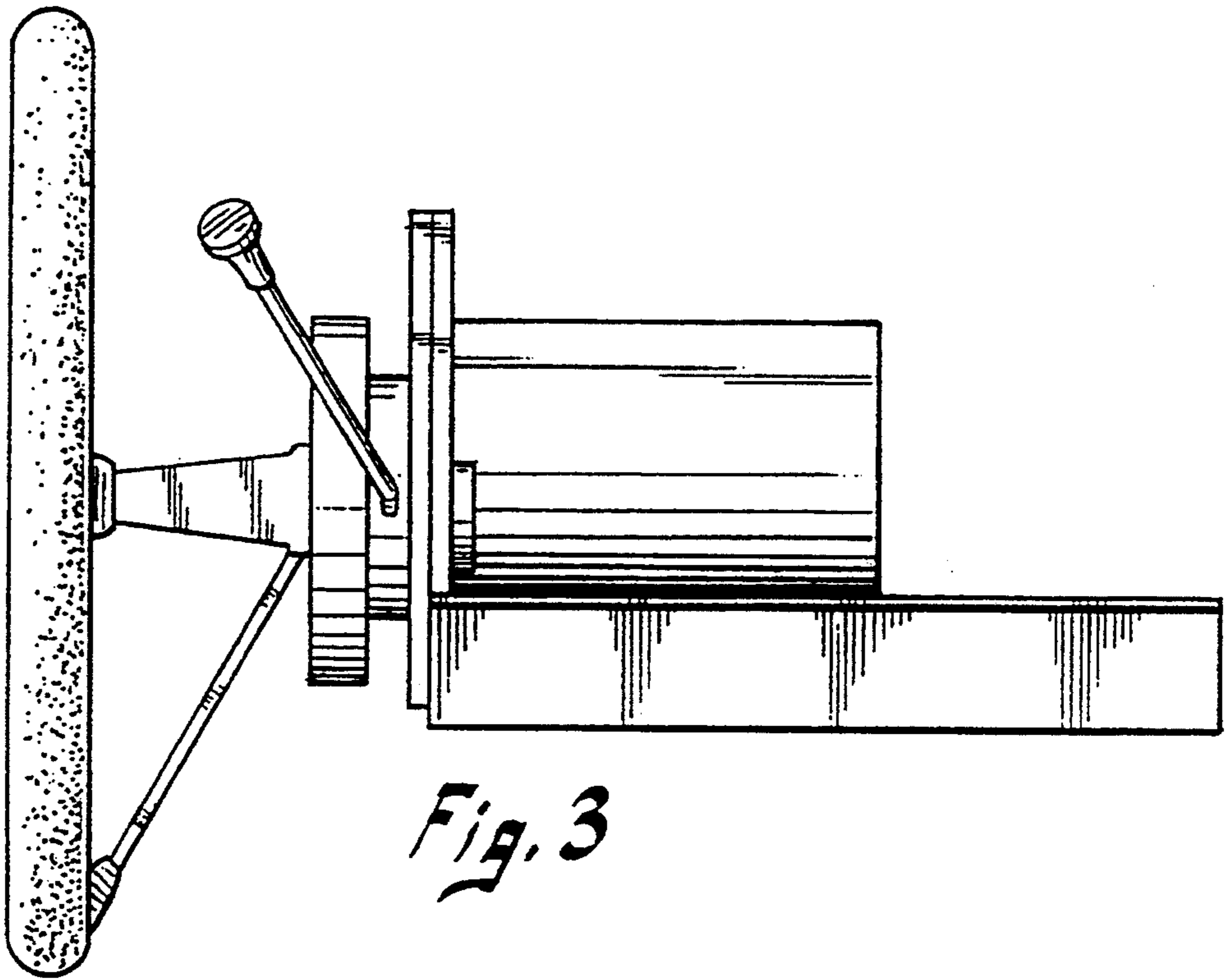
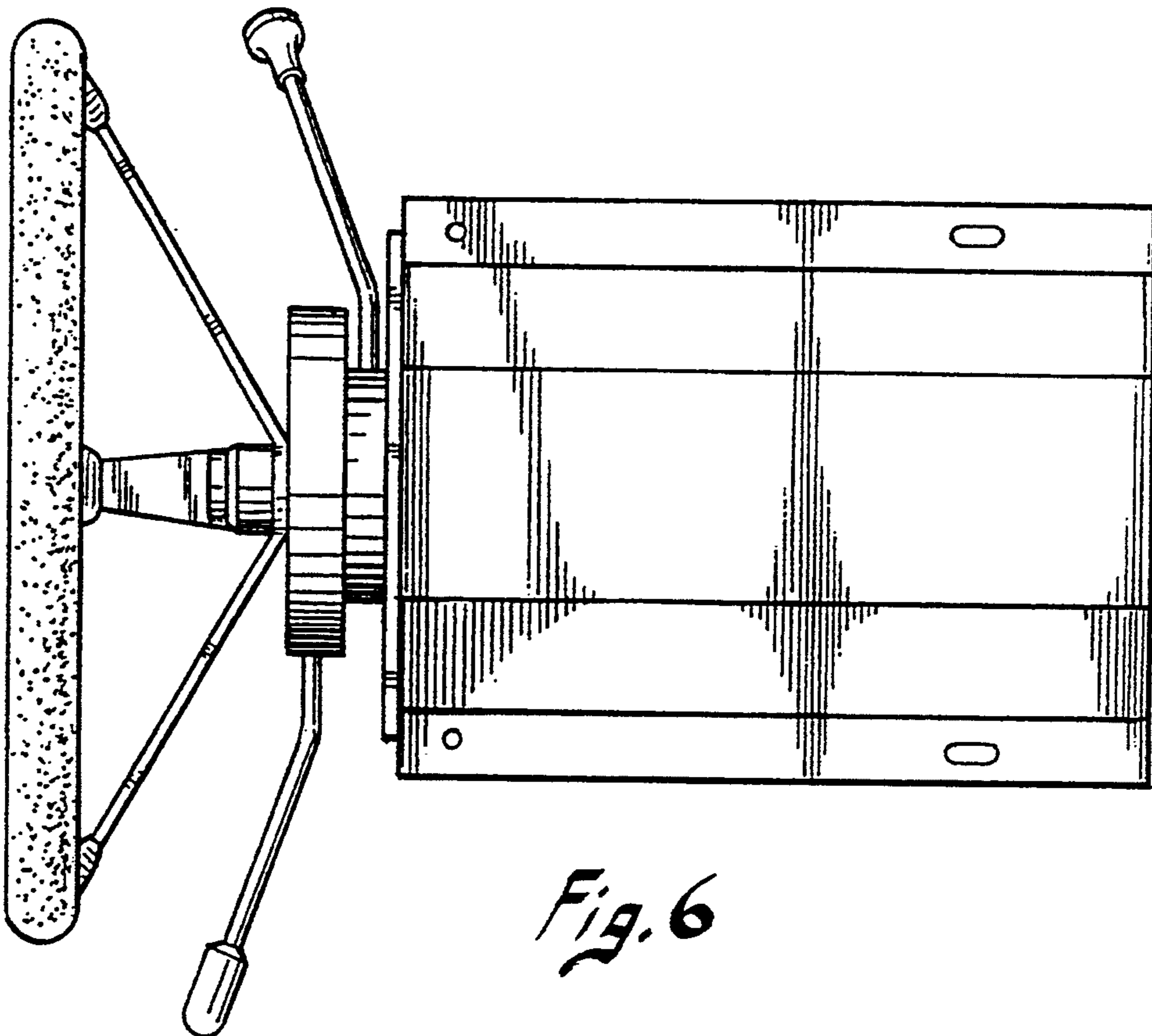
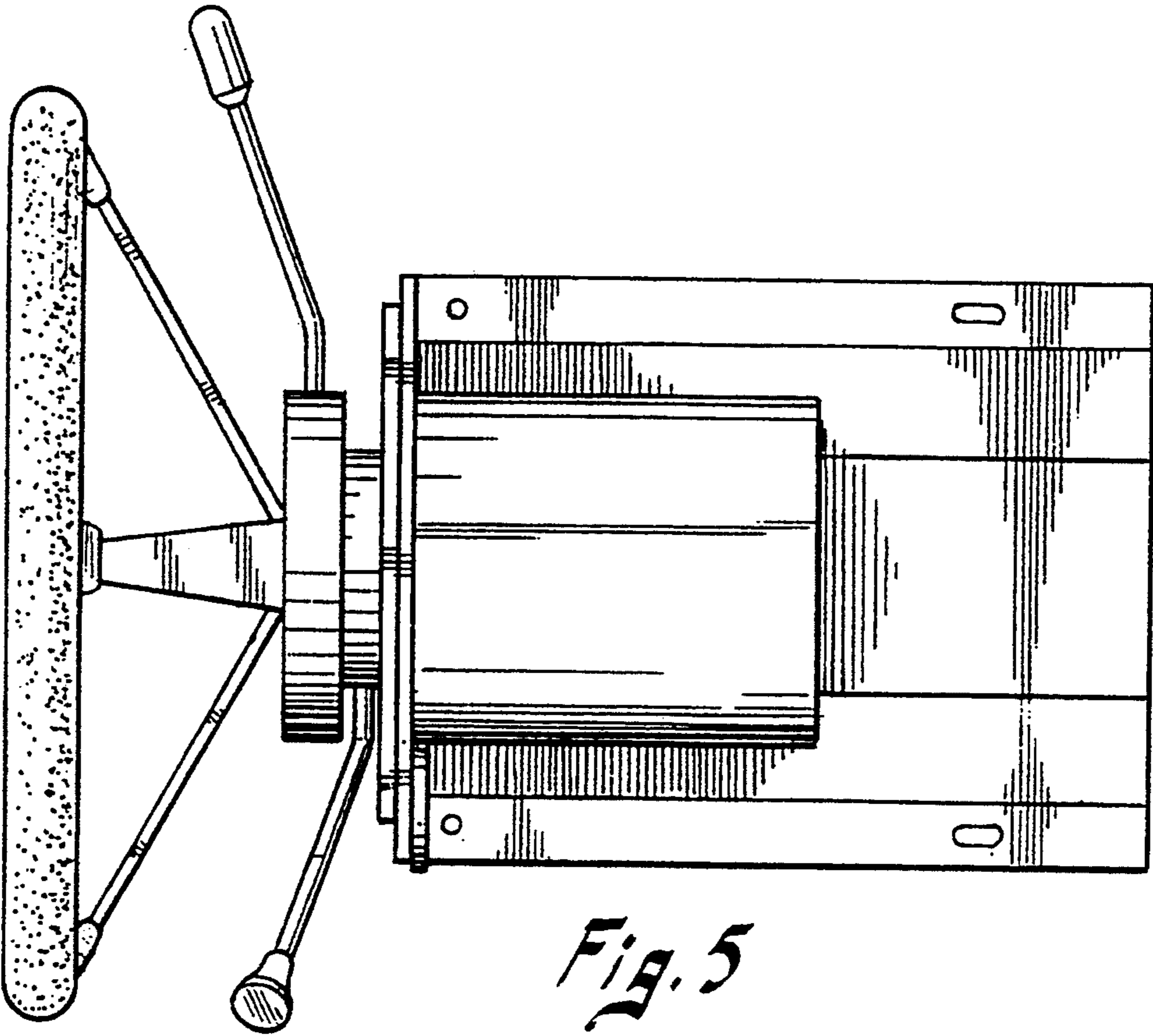

Fig. 2





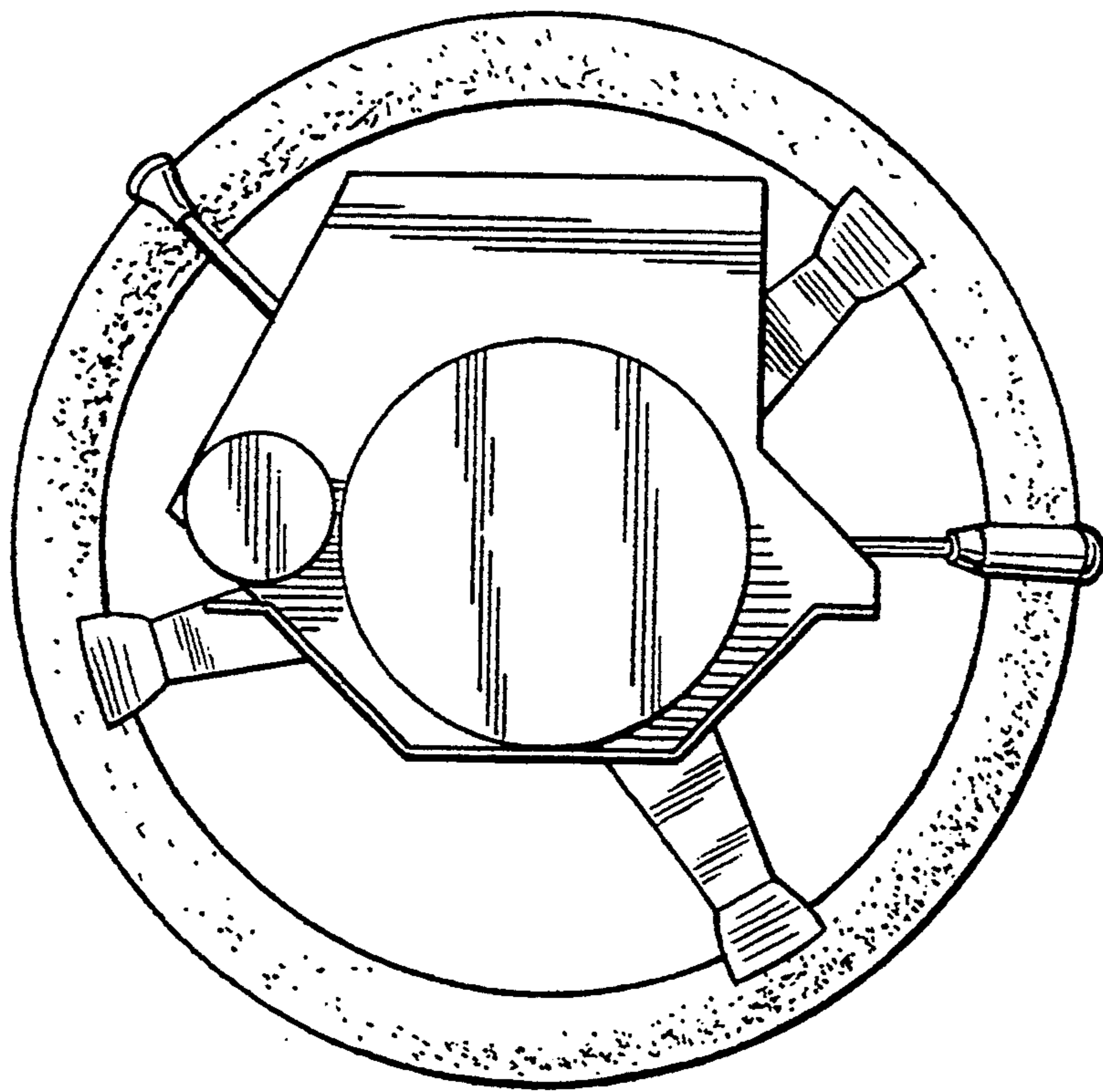

Fig. 7