



US00D355878S

United States Patent [19]

[11] Patent Number: Des. 355,878

Jenkins et al.

[45] Date of Patent: ** Feb. 28, 1995

[54] VEHICLE TOWING BAR

5,066,034 11/1991 Carr 280/420

[76] Inventors: **William K. Jenkins**, 8200 Jantzen Rd.
- Space 6, Modesto, Calif. 95357;
Ronald L. Bonzi, 1105 Durant St.,
Modesto, Calif. 95350

Primary Examiner—Wallace R. Burke
Assistant Examiner—M. Brown
Attorney, Agent, or Firm—Lothrop & West

[**] Term: 14 Years

[57] CLAIM

[21] Appl. No.: 13,342

The ornamental design for a vehicle towing bar, as shown and described.

[22] Filed: Sep. 22, 1993

DESCRIPTION

[52] U.S. Cl. D12/162

[58] Field of Search D12/162; 280/423.1,
280/416.1, 456.1, 507, 476.1, 508, 402, 420, 421

FIG. 1 is a left front perspective of a vehicle towing bar, showing our new design;

FIG. 2 is a side elevational view thereof, the opposite side elevational view being substantially a mirror image, thereof;

FIG. 3 is a top plan view, thereof;

FIG. 4 is a bottom plan view, thereof;

FIG. 5 is a front elevational view, thereof; and,

FIG. 6 is is a rear elevational view thereof.

[56] References Cited

U.S. PATENT DOCUMENTS

D. 341,805 11/1993 Johnsen D12/162
4,890,852 1/1990 Chapman 280/402
4,993,909 2/1991 Hamman 280/402

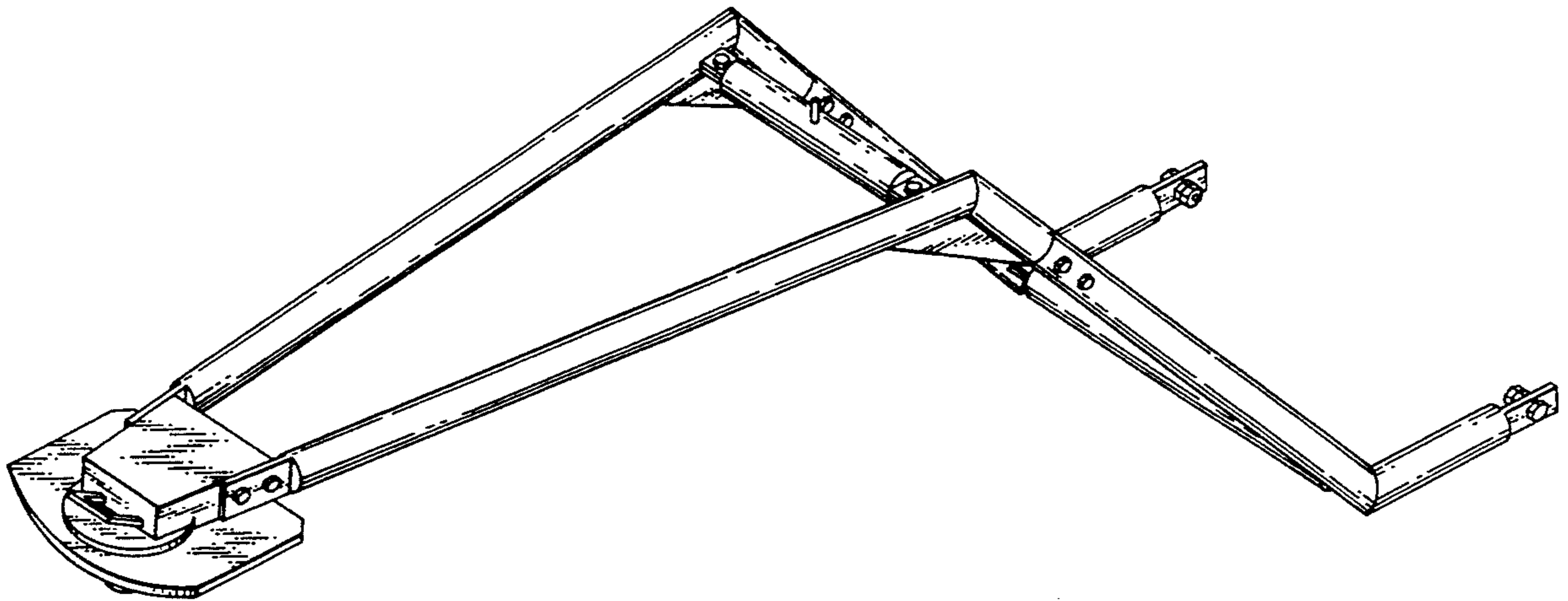

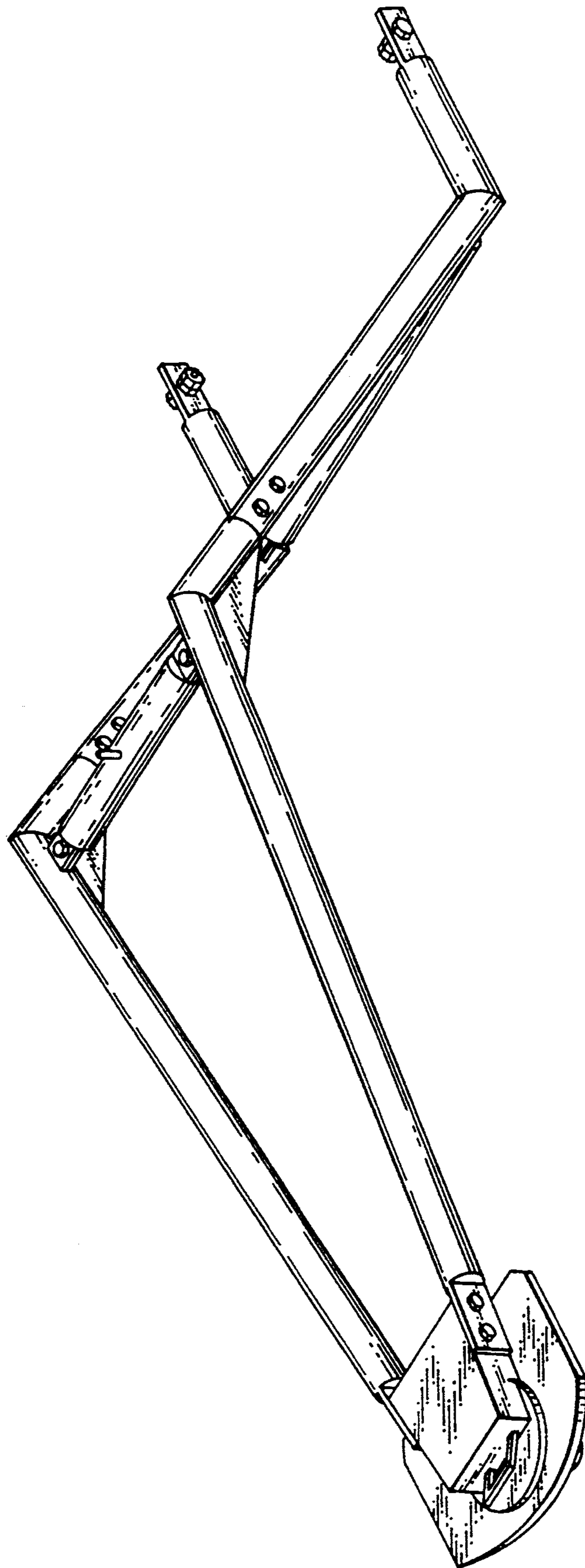
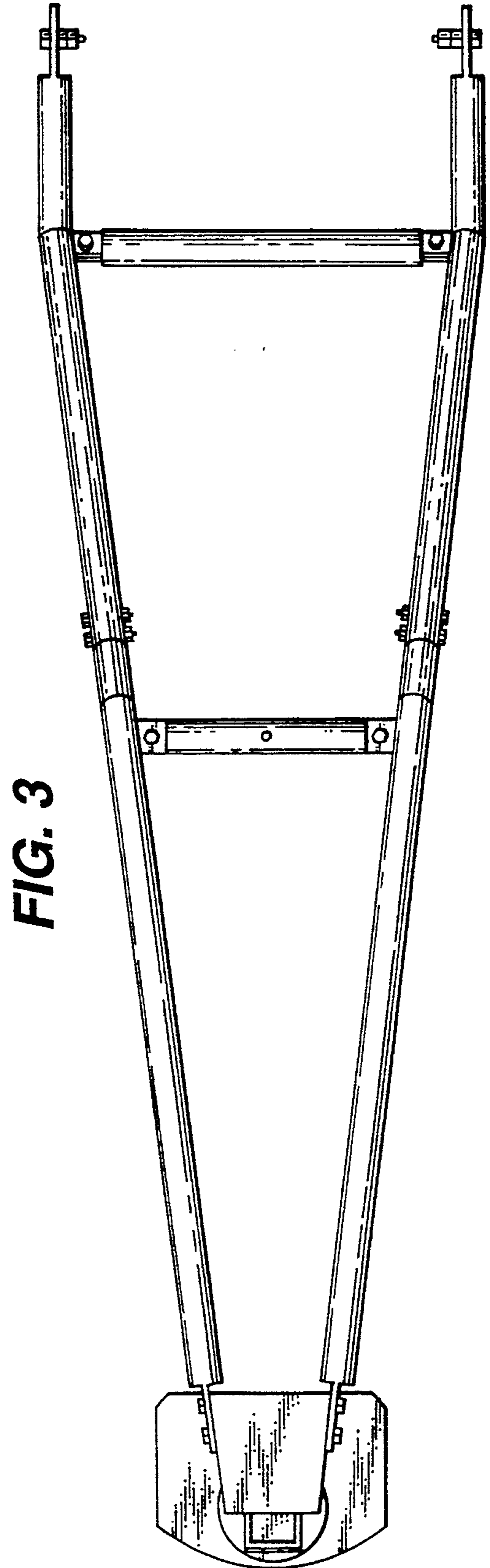
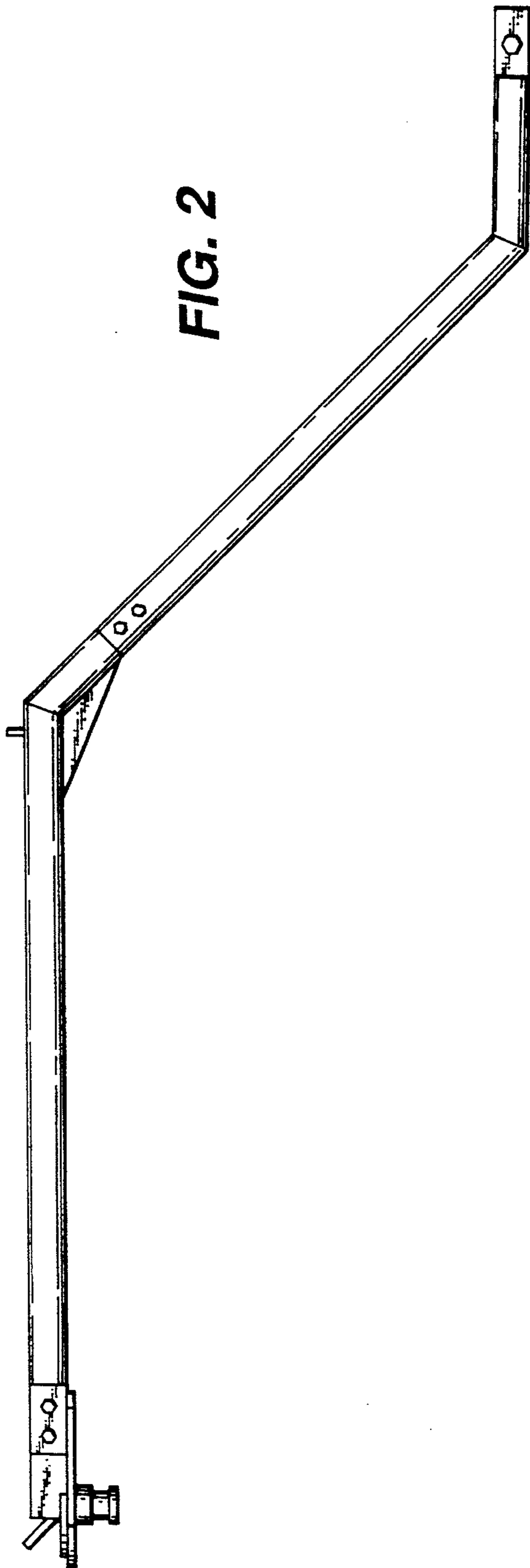

FIG. 1



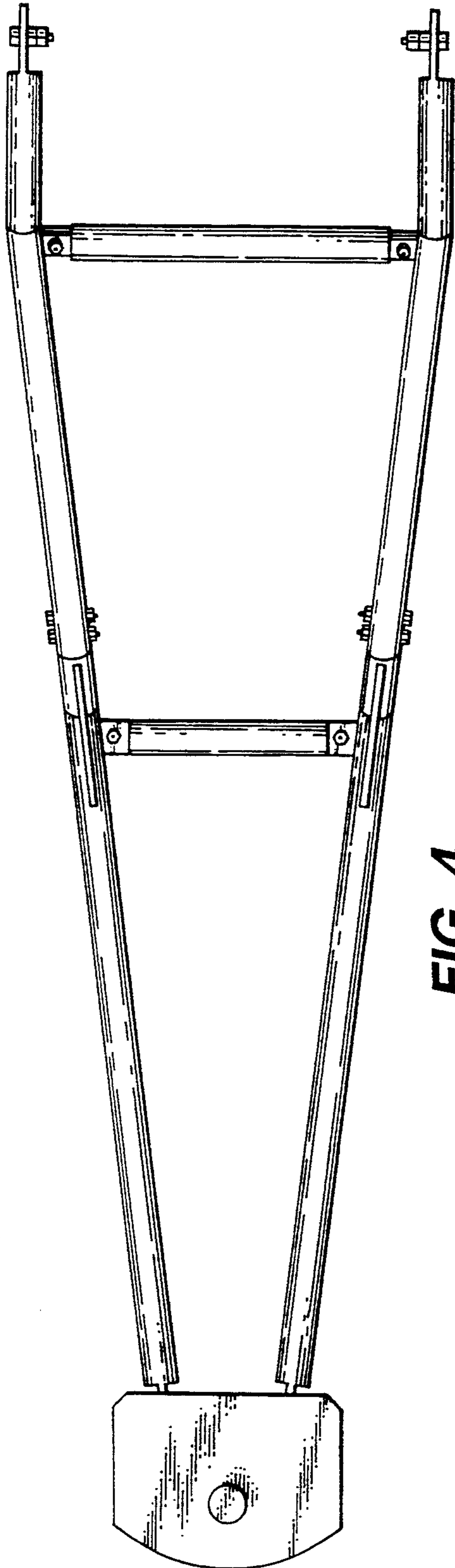

FIG. 4

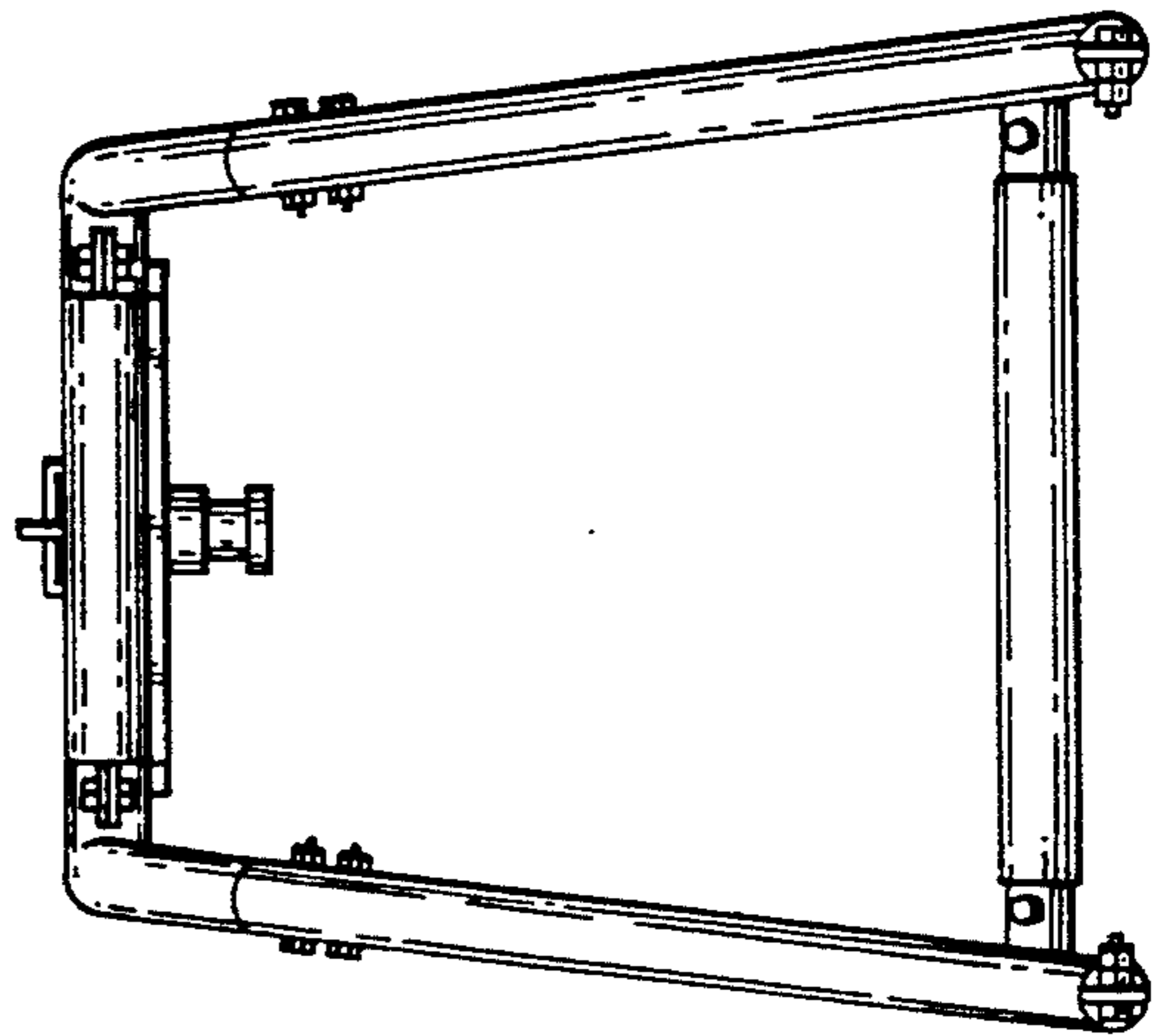

FIG. 5

FIG. 6

