



US00D355777S

United States Patent [19]

[11] Patent Number: **Des. 355,777**

Emoto

[45] Date of Patent: **** Feb. 28, 1995**

[54] VEHICLE SEAT

DESCRIPTION

- [75] Inventor: **Seiji Emoto**, Huntington Beach, Calif.
- [73] Assignee: **Isuzu Motors Limited**, Tokyo, Japan
- [**] Term: **14 Years**
- [21] Appl. No.: **780,745**
- [22] Filed: **Oct. 21, 1991**
- [52] U.S. Cl. **D6/356; D6/334**
- [58] Field of Search **D6/341, 356, 377, 334, D6/335, 336, 349; 297/452.17, 257, 377, 113, 115, 188.12, 188.14, 181, 192, 378.12, 452.41**

FIG. 1 is a top, right perspective view of my new vehicle seat design;
 FIG. 2 is a top plan view of my new vehicle seat design;
 FIG. 3 is front elevation view of my new vehicle seat design;
 FIG. 4 is a rear elevation view of my new vehicle seat design;
 FIG. 5 is a right elevation view of my new vehicle seat design;
 FIG. 6 is a left elevation view of my new vehicle seat design;
 FIG. 7 is a right elevation view of my new vehicle seats design shown with the right-hand seat reclined and shifted forward and with the center portion folded forward and shifted forward;
 FIG. 8 is a top plan view of my new vehicle seats design shown with the right-hand seat reclined and shifted forward and with the center portion folded forward and shifted forward. A top plan view of a further vehicle seat, located rearward of vehicle seats according to my new vehicle seats design, is shown in phantom. The design of the reclined right-hand seat flows into the design of the further vehicle seat; and,
 FIG. 9 is a right, front perspective view of my new vehicle seats design. A right, front perspective view of a further vehicle seat, located rearward of vehicle seats according to my new vehicle seat design, is shown in phantom. As in FIG. 8, the right-hand seat reclined and shifted forward and with the center portion folded forward and shifted forward and the design of the reclined right-hand seat flows into the design of the further vehicle seat.

[56] References Cited

U.S. PATENT DOCUMENTS

2,966,201	12/1960	Strahler	D6/333	X
4,132,447	1/1979	Terada	297/378.12	X
5,188,442	2/1993	Harty et al.	297/192	X
5,246,267	9/1993	Nagashima et al.	297/113	

FOREIGN PATENT DOCUMENTS

515726	8/1955	Canada	297/378.12
2615799	12/1988	France	297/115

Primary Examiner—Wallace R. Burke
Assistant Examiner—Monica A. Hannon
Attorney, Agent, or Firm—Thomas A. Gallagher

[57] CLAIM

The ornamental design for vehicle seat, as shown and described.

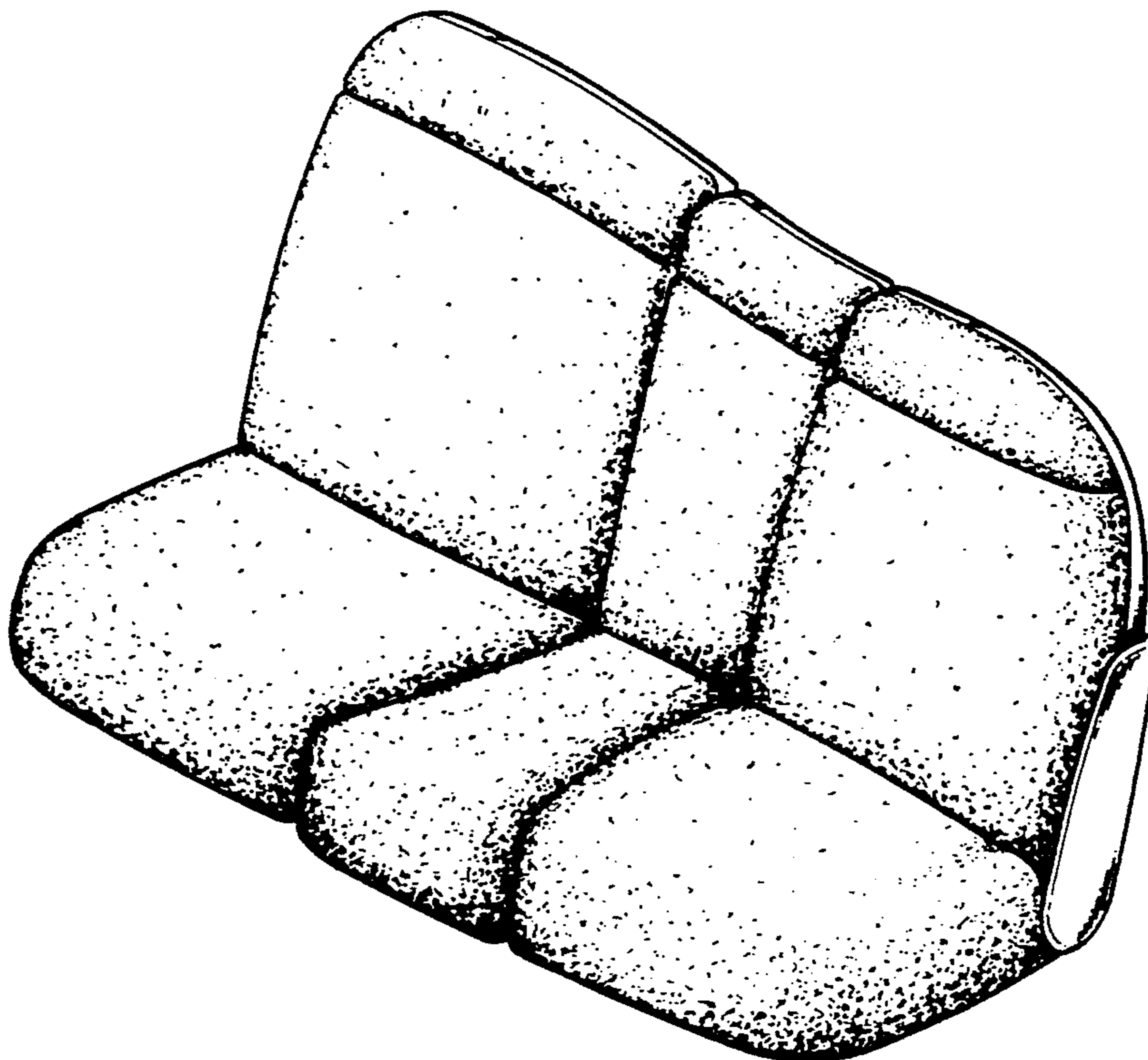

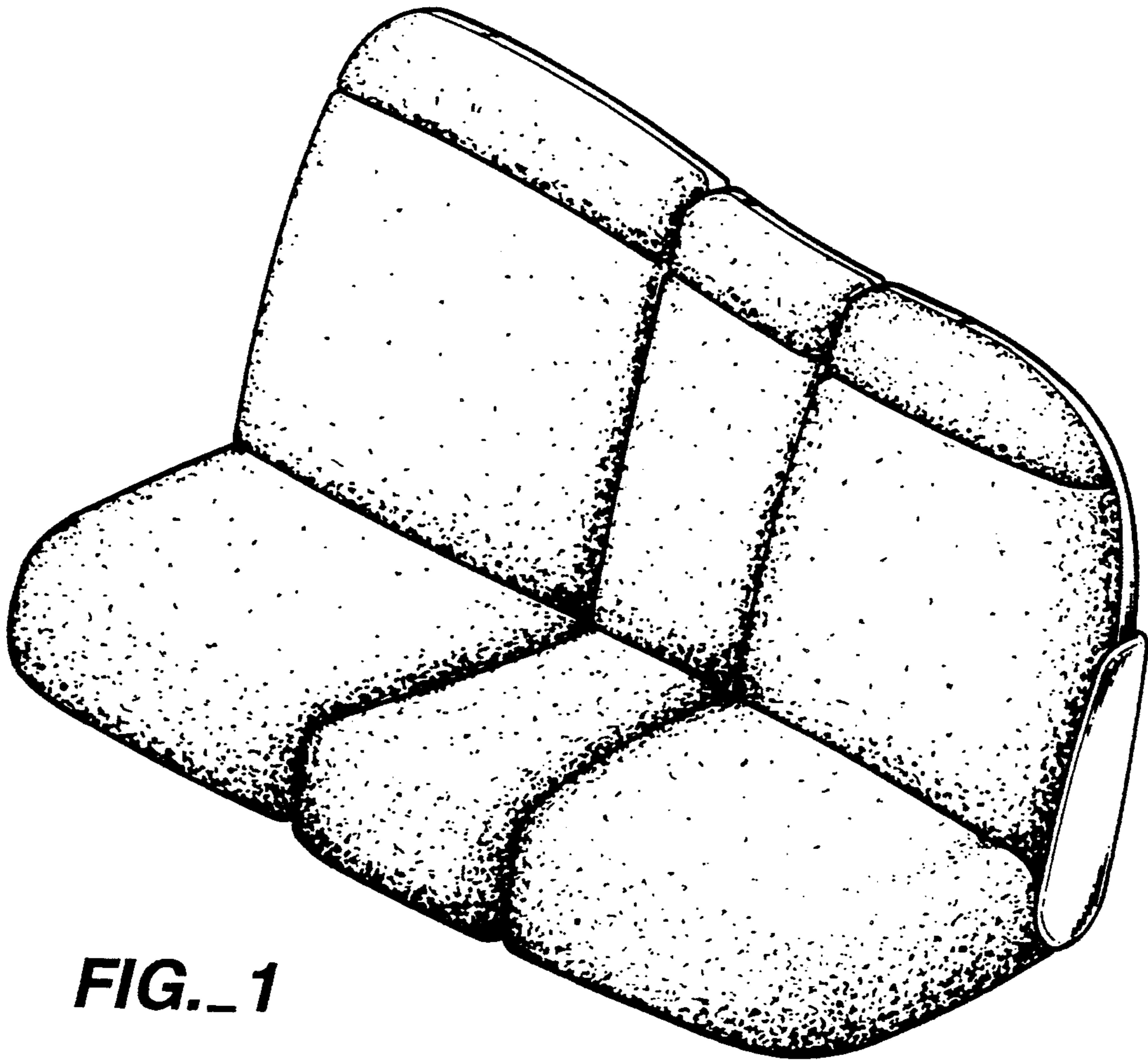

FIG. 1

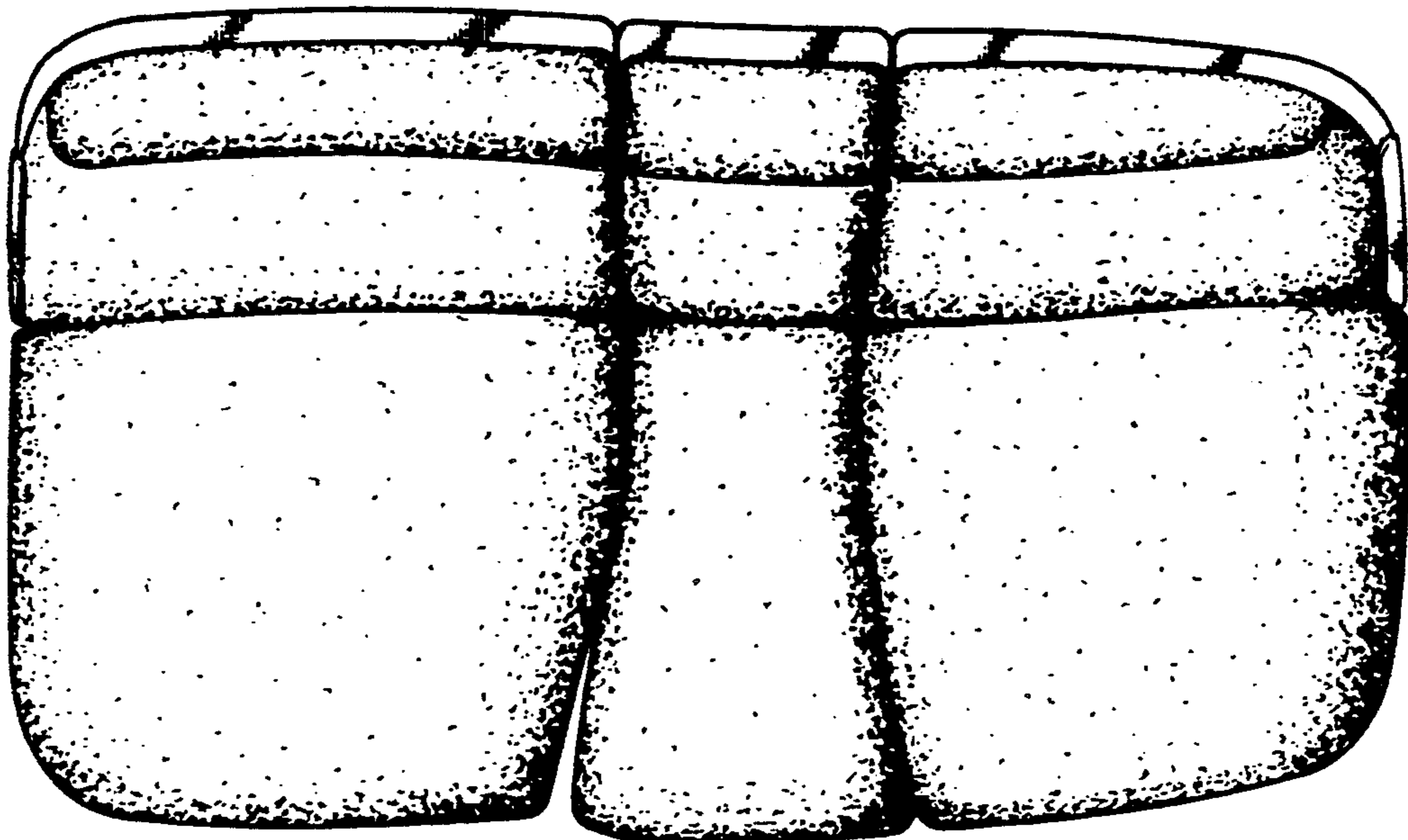

FIG. 2

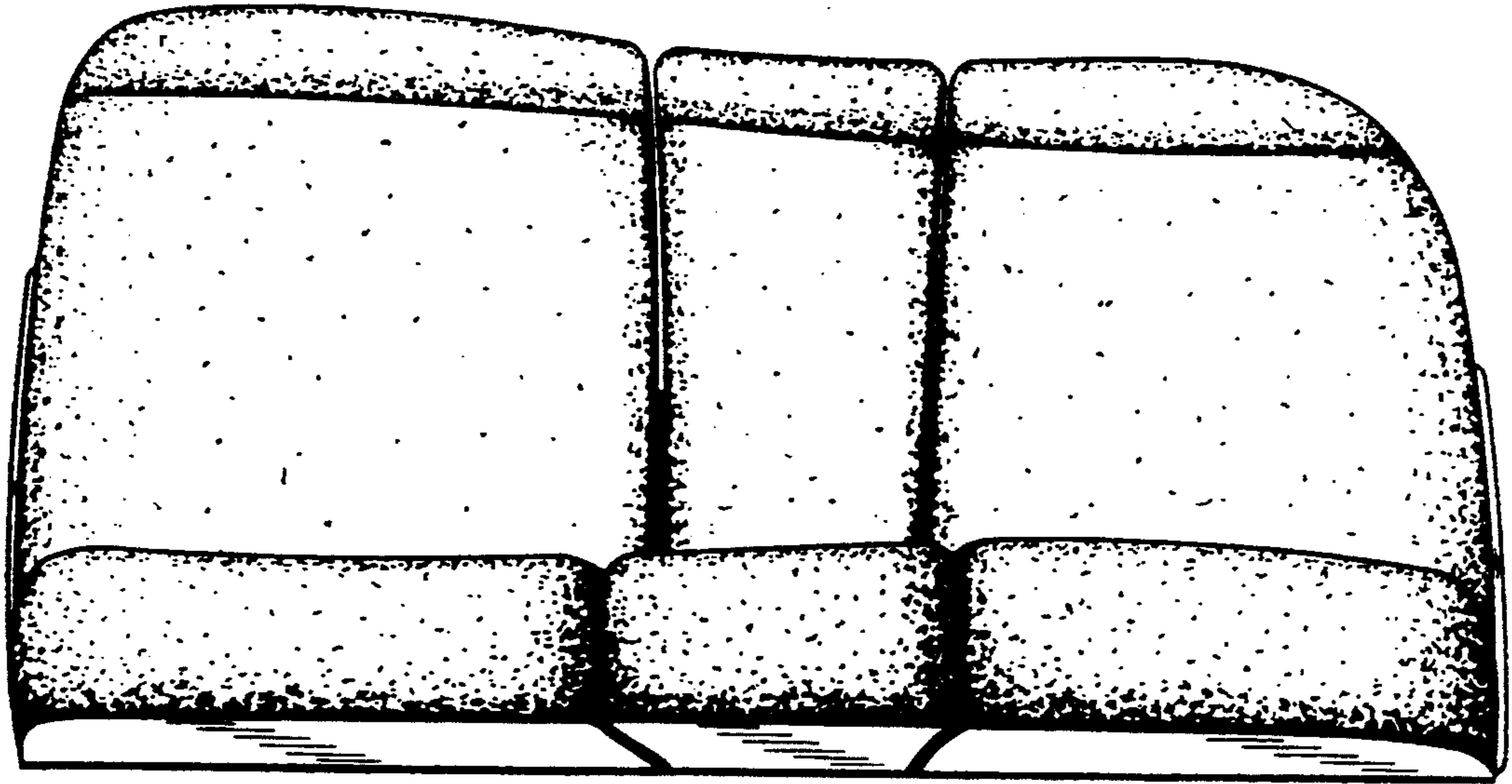

FIG._3

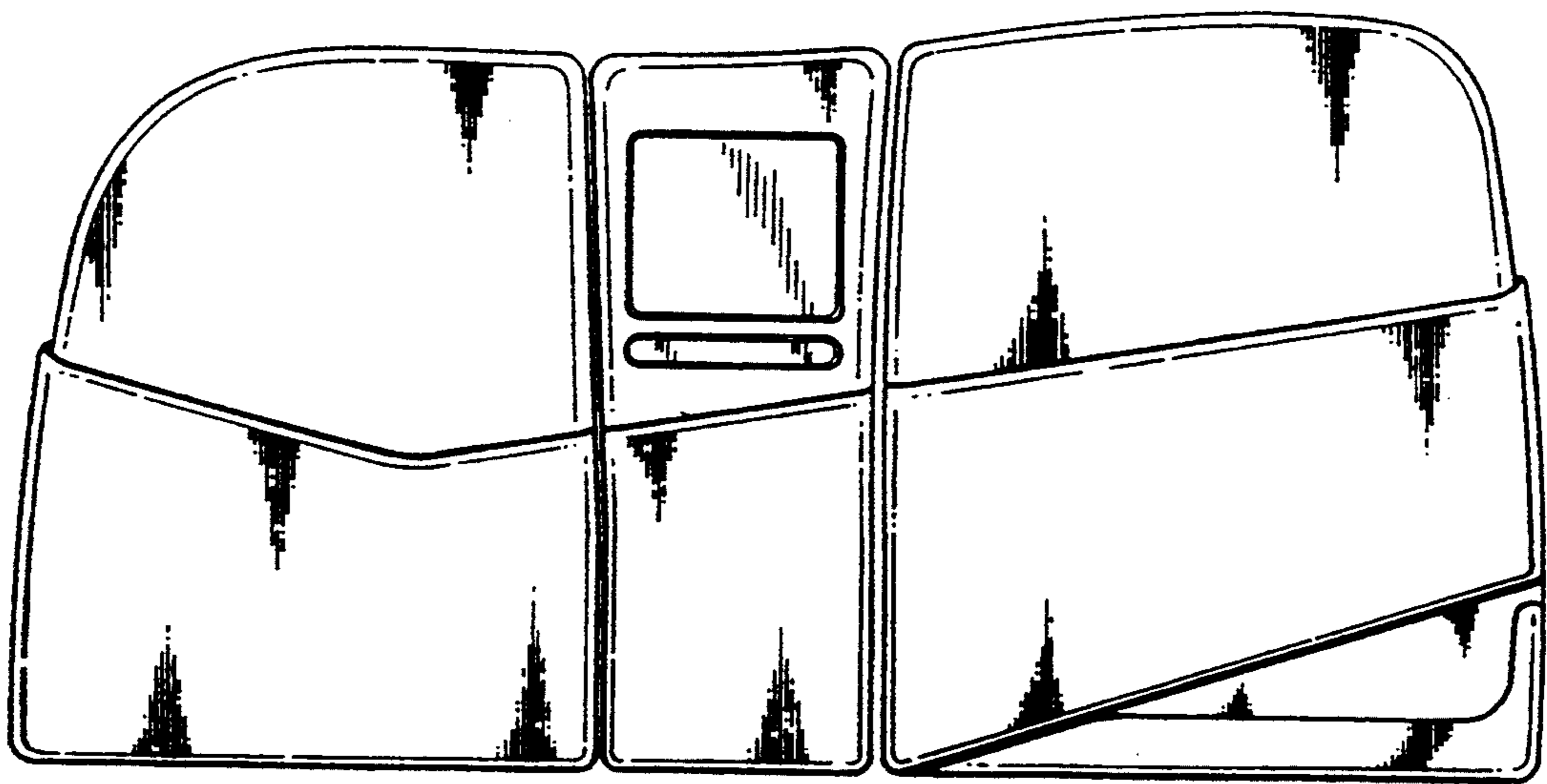

FIG._4

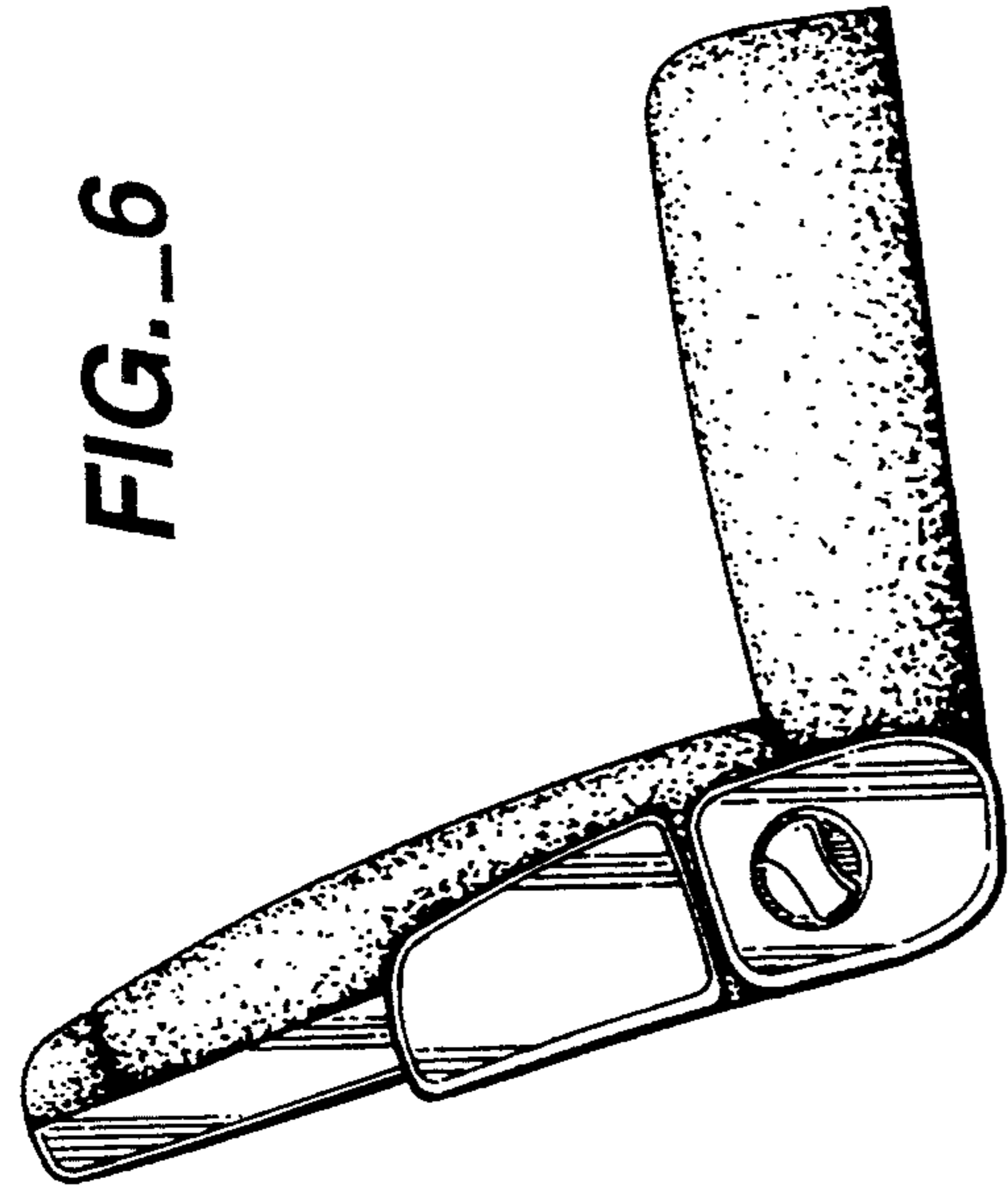

FIG. 6

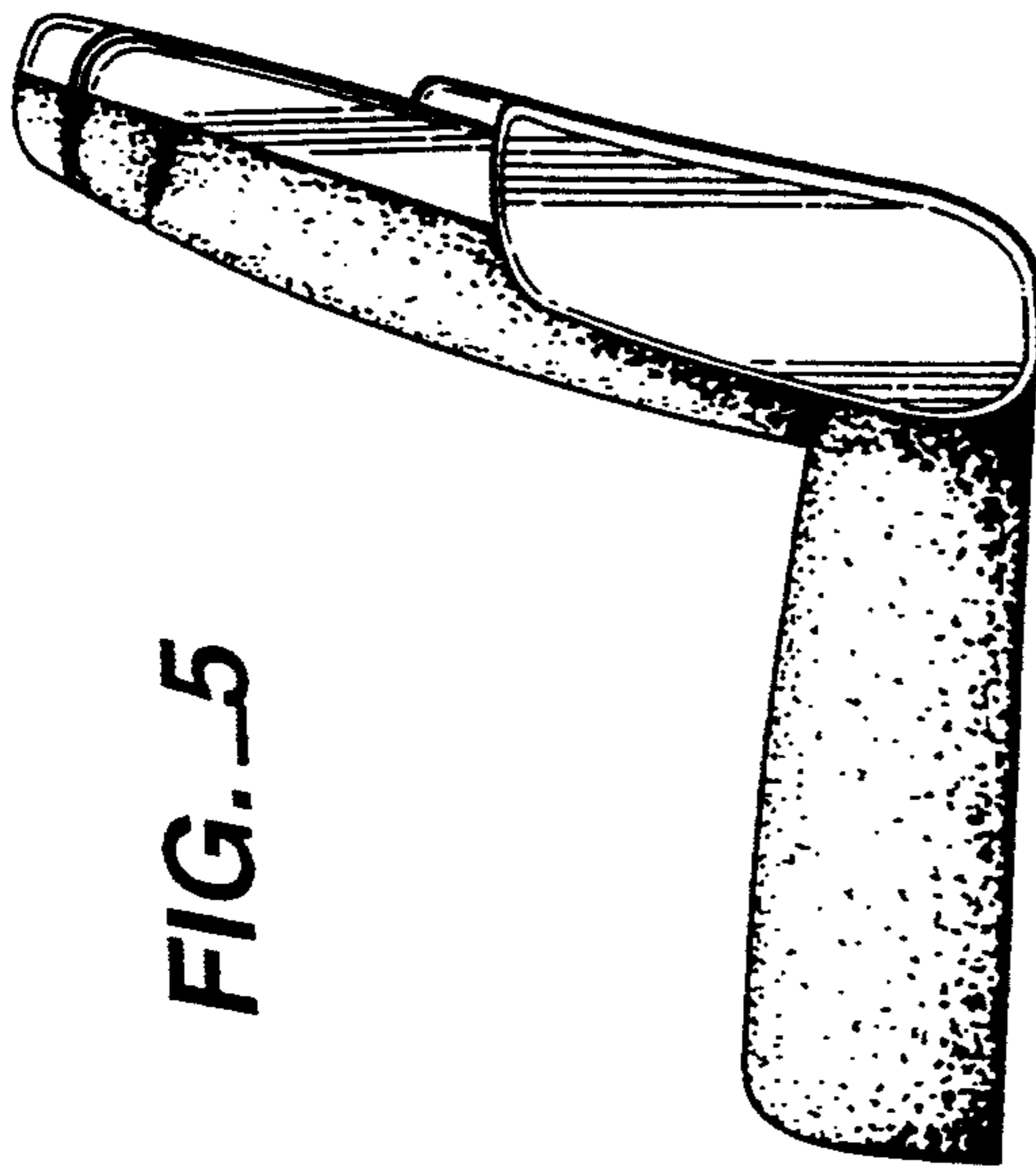

FIG. 5

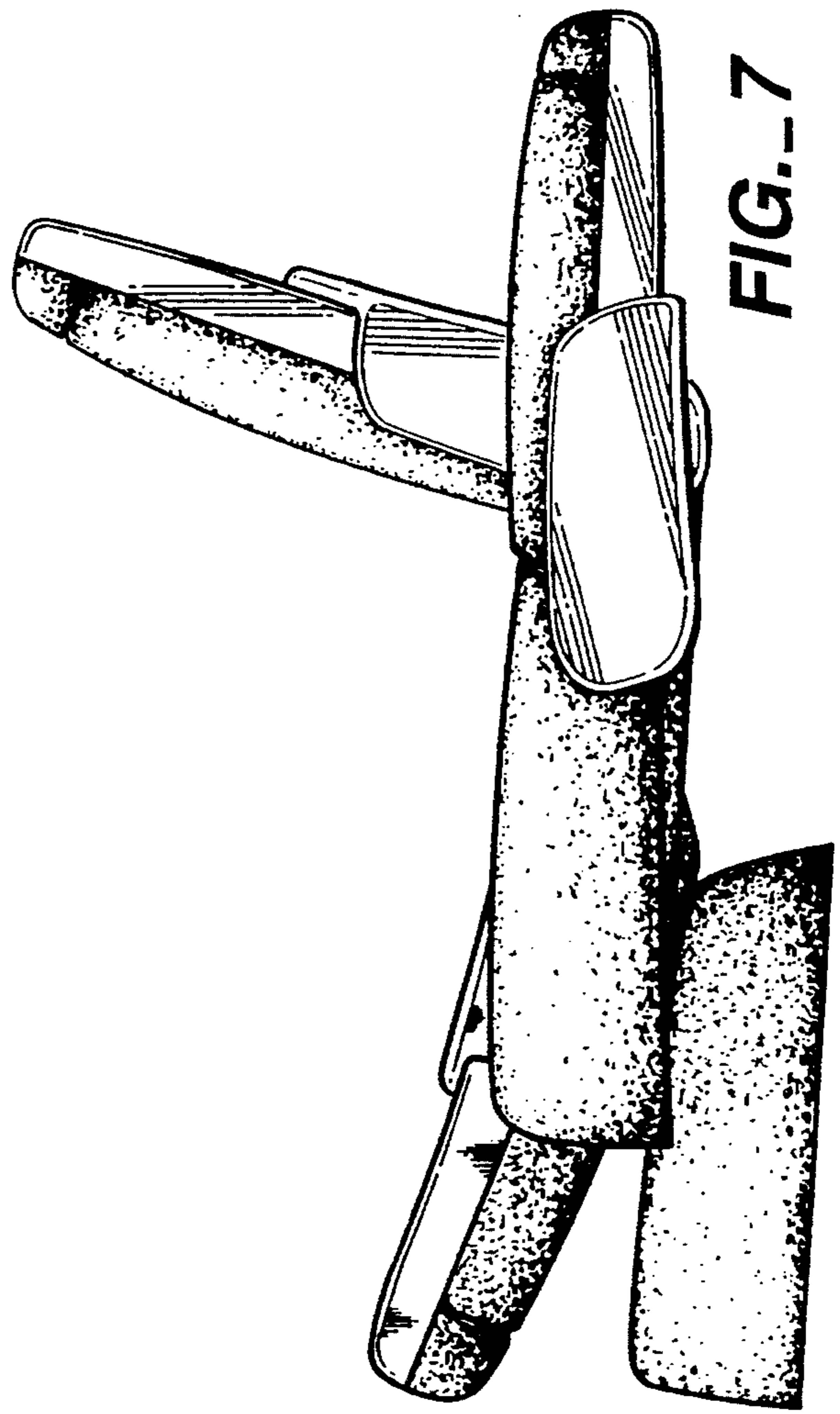

FIG. 7

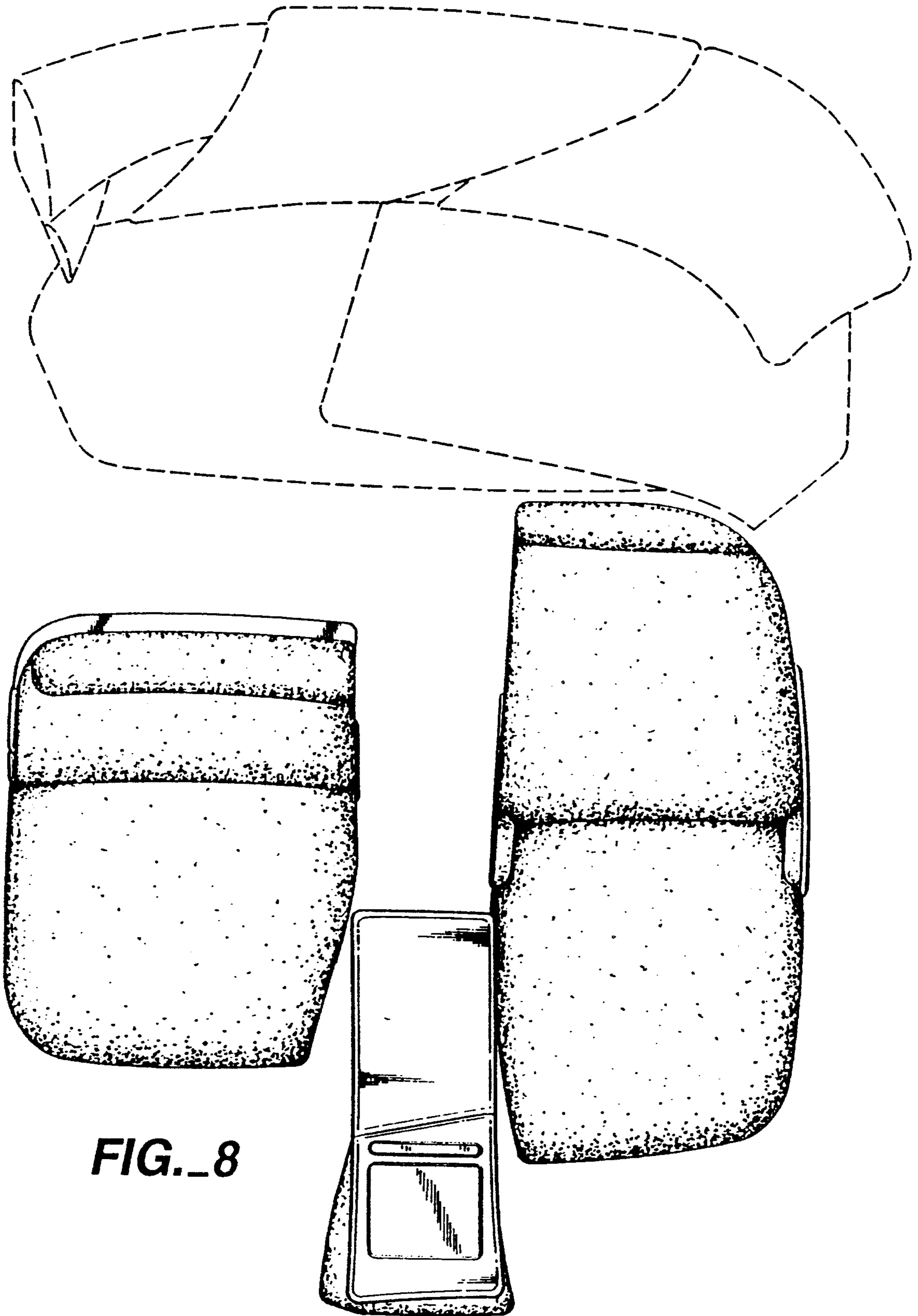

FIG. 8

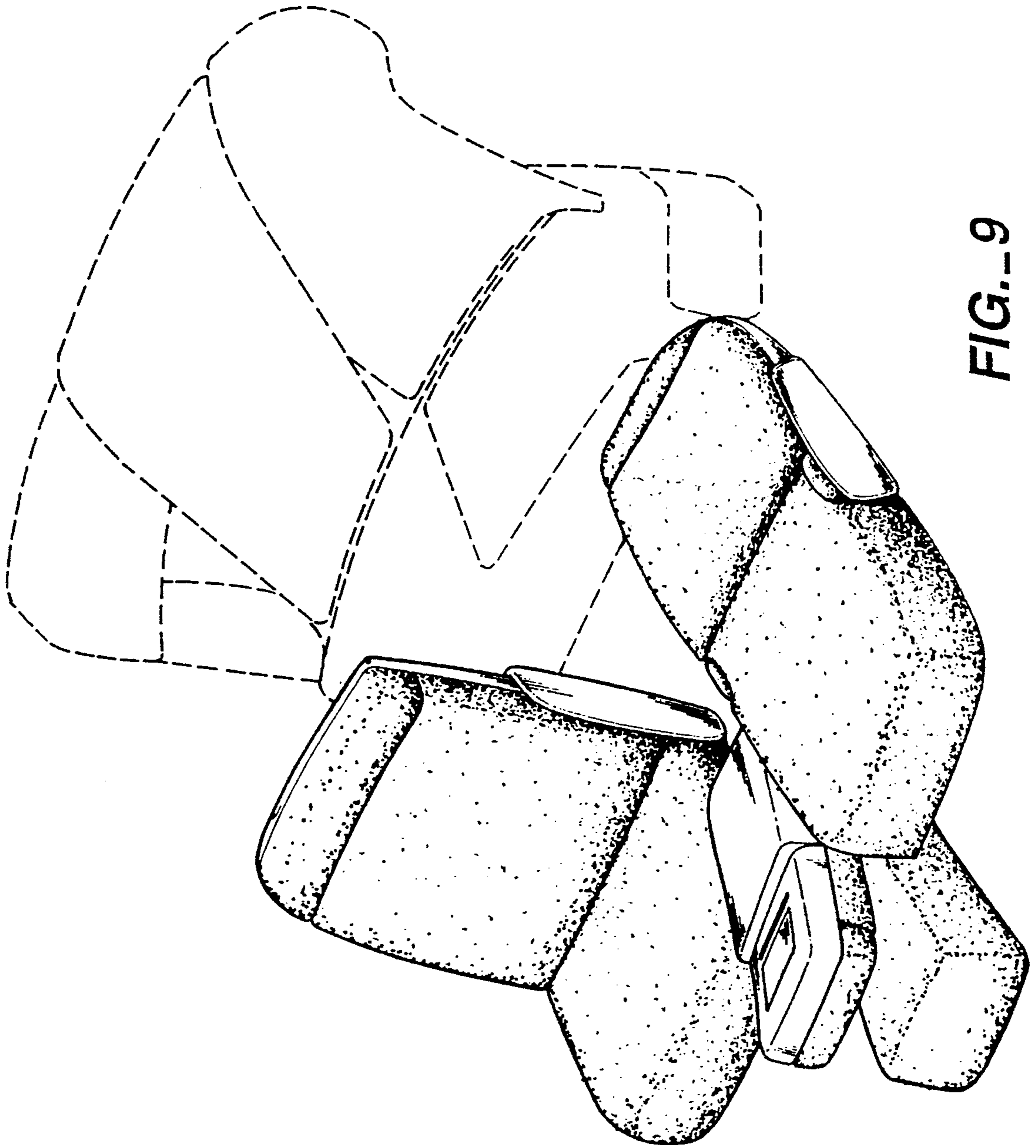

FIG.-9