



US00D355655S

# United States Patent [19]

[11] Patent Number: **Des. 355,655**

Burke

[45] Date of Patent: **\*\* Feb. 21, 1995**

[54] CONTROL PANEL FOR A VIDEO EDITING SYSTEM

D. 343,622 1/1994 Hanke ..... D14/217  
D. 347,424 5/1994 Hill ..... D14/125

[75] Inventor: **Jonathan Burke**, Corte Madera, Calif.

### OTHER PUBLICATIONS

Brochure entitled, "Sabre 4100 Dynamic Editing System," by The Grass Valley Group, Inc., six pages, 1992. Video Review, Dec. 1988, p. 36, Digital AV Editor.

[73] Assignee: **ImMIX**, a division of Carlton Int'l. Corp., Grass Valley, Calif.

*Primary Examiner*—Theodore M. Shooman

[\*\*] Term: **14 Years**

### [57] CLAIM

[21] Appl. No.: **4,122**

The ornamental design for a control panel for a video editing system, as shown.

[22] Filed: **Jan. 27, 1993**

### DESCRIPTION

[52] U.S. Cl. .... **D14/217**

[58] Field of Search ..... D14/124, 125, 160, 163, D14/165, 167, 217, 239, 299

FIG. 1 is a perspective view of the control panel; FIG. 2 is a top plan view of the control panel; FIG. 3 is a left side elevational view of the control panel; FIG. 4 is a right side elevational view of the control panel; FIG. 5 is a back elevational view of the control panel; and, FIG. 6 is a bottom plan view of the control panel.

### [56] References Cited

#### U.S. PATENT DOCUMENTS

D. 323,506 1/1992 Breslau ..... D14/217  
D. 338,017 8/1993 Mohri ..... D14/239  
D. 341,833 11/1993 MacKay et al. .... D14/217  
D. 341,834 11/1993 MacKay et al. .... D14/217

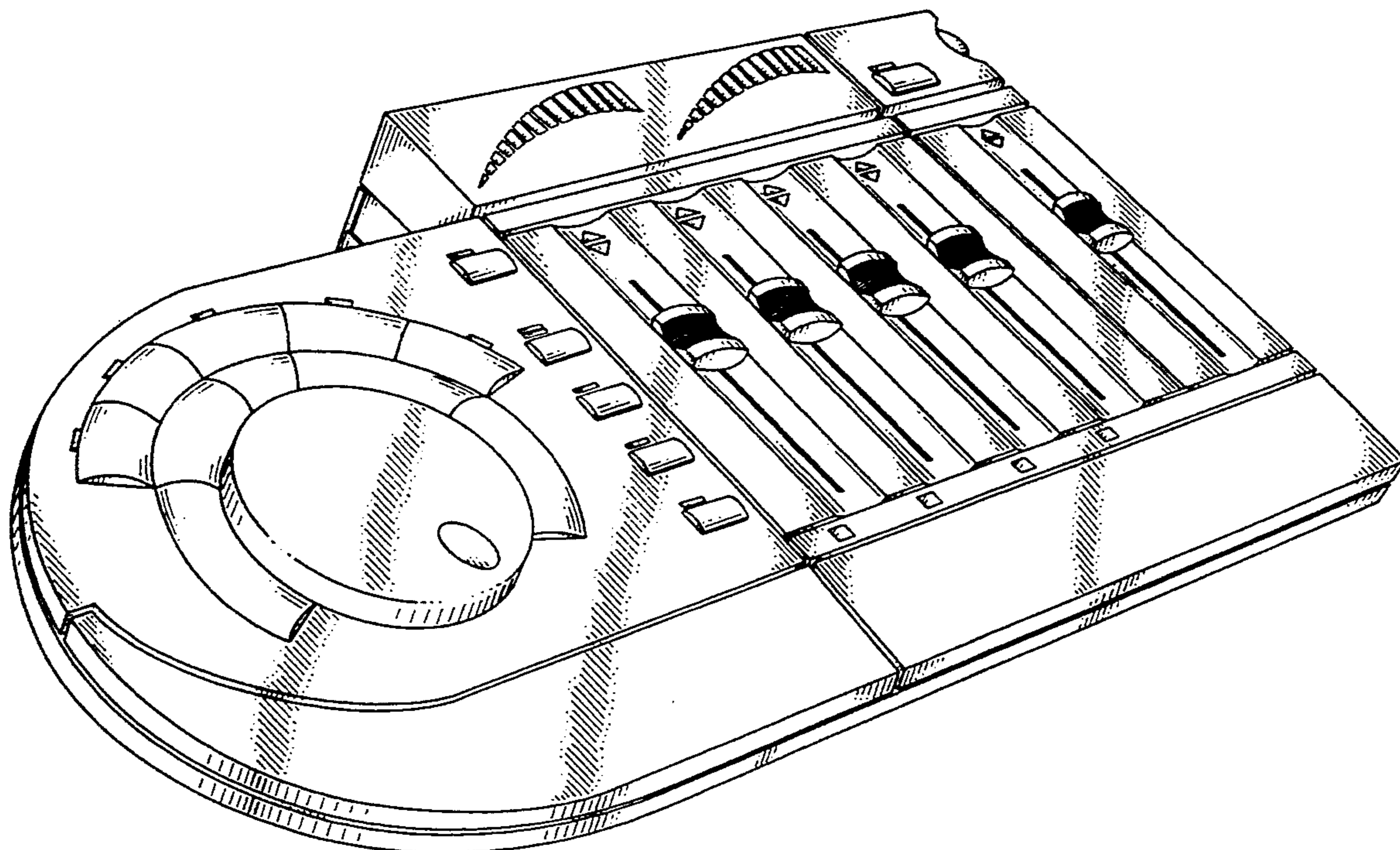

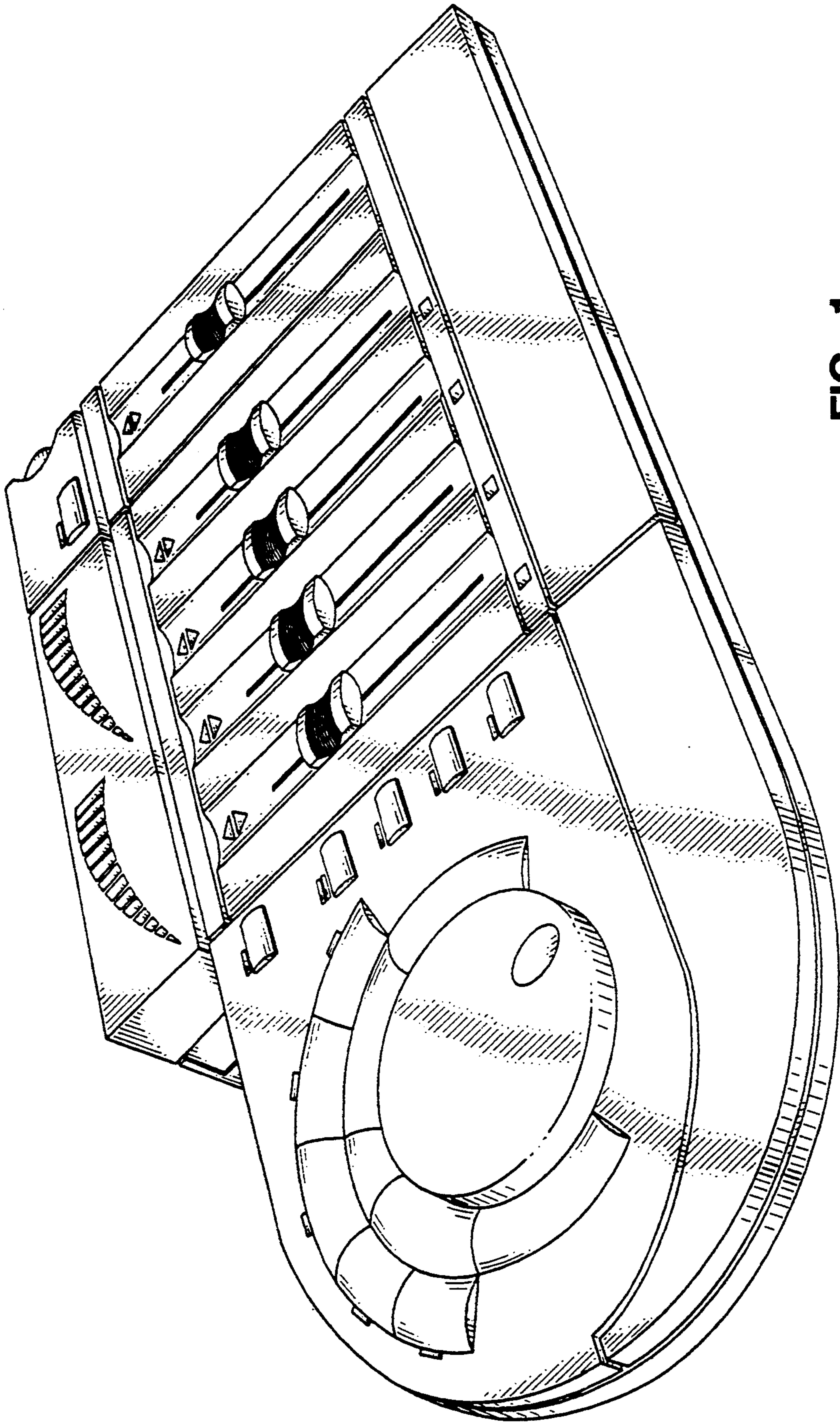

FIG. 1



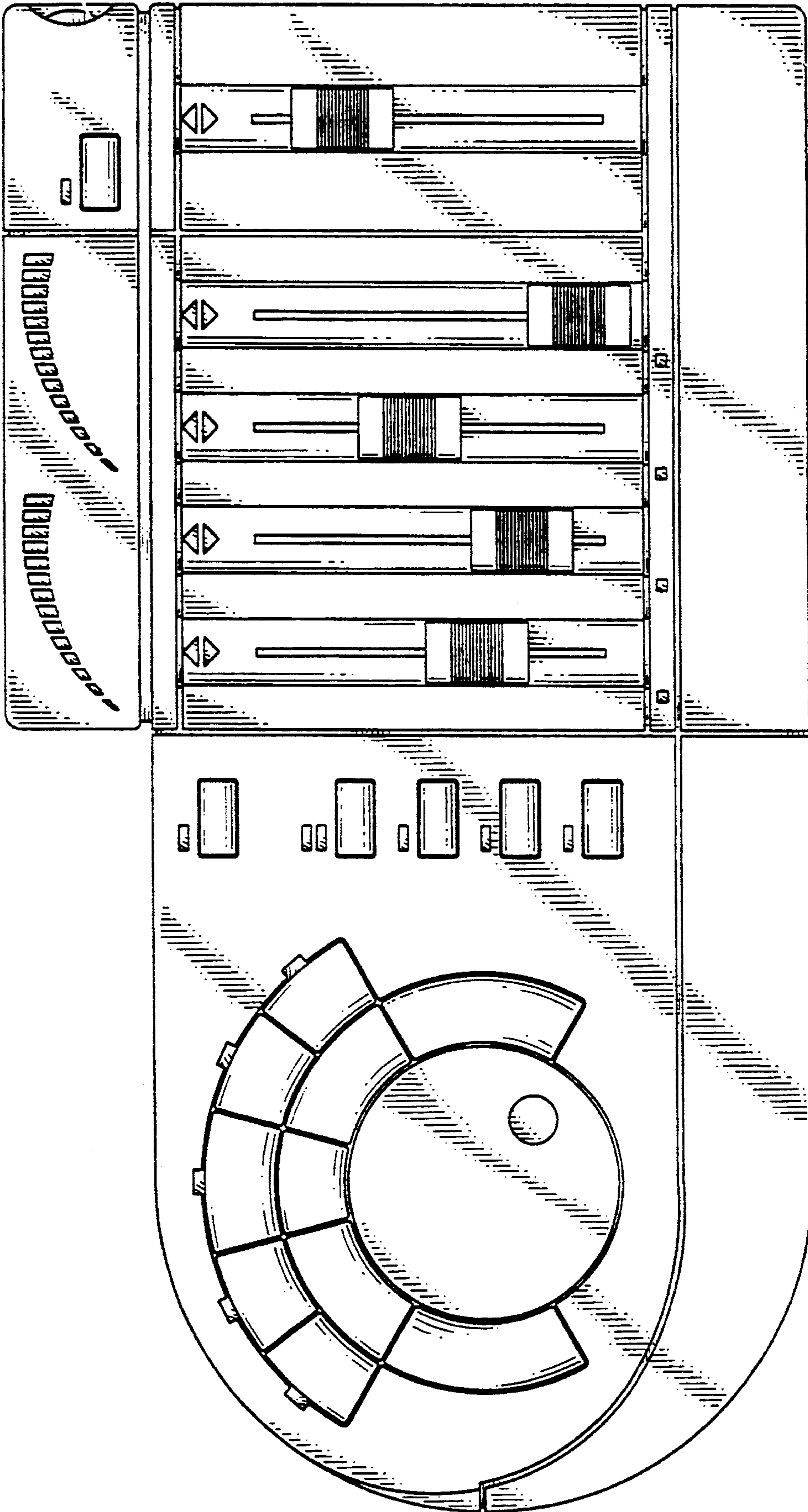

FIG. 2

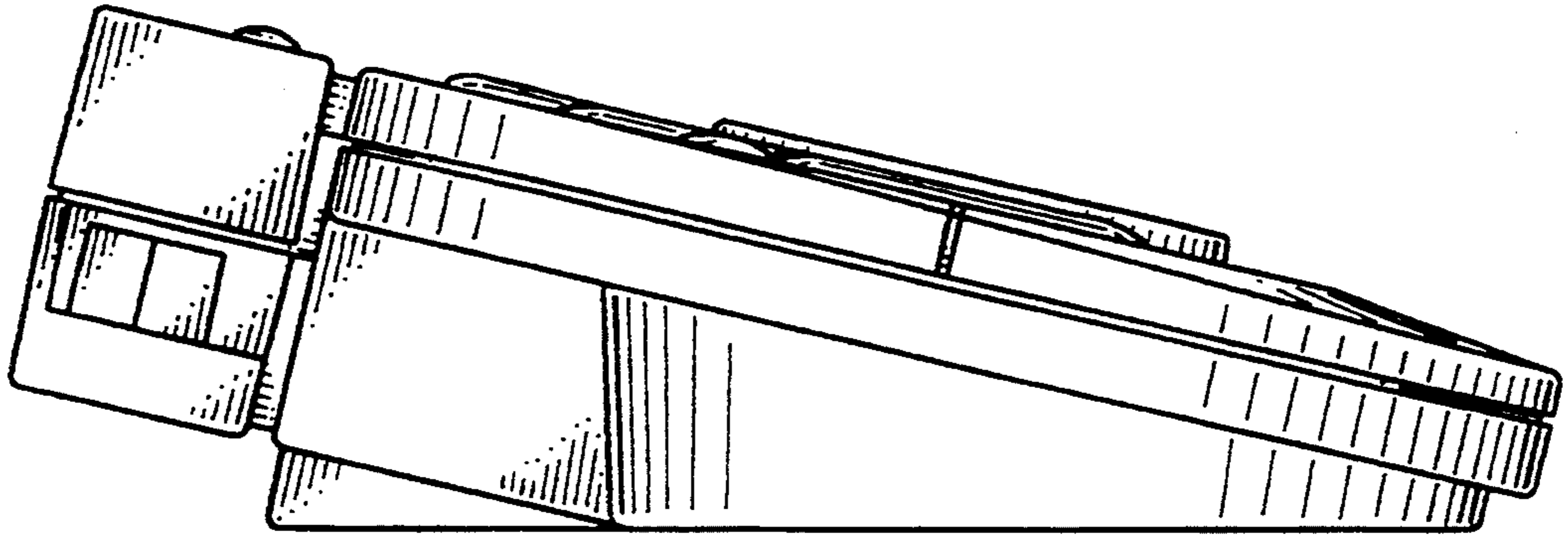

FIG. 3

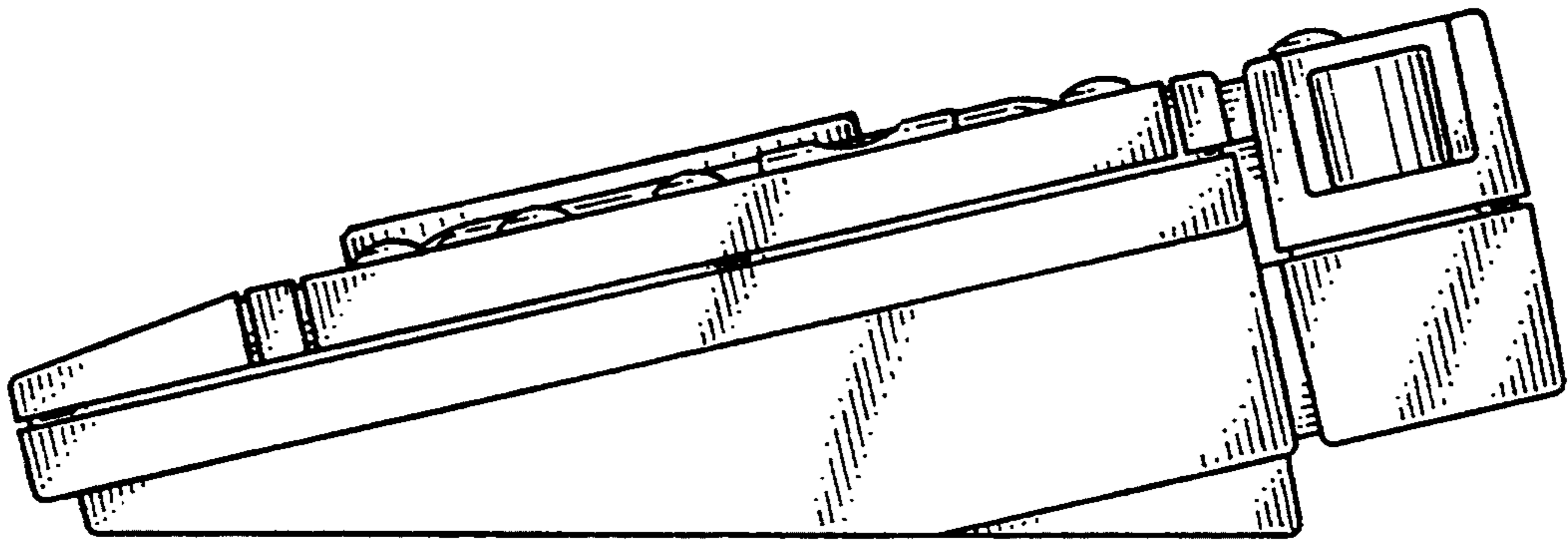

FIG. 4

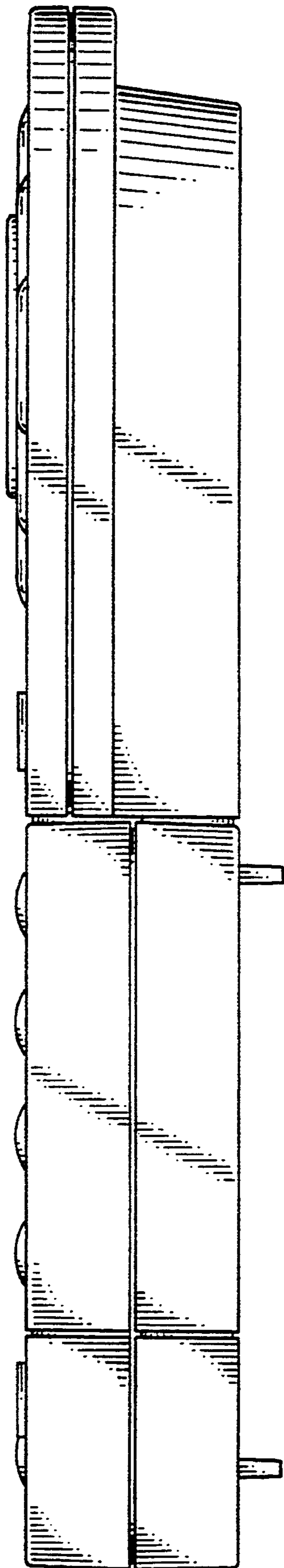

FIG. 5

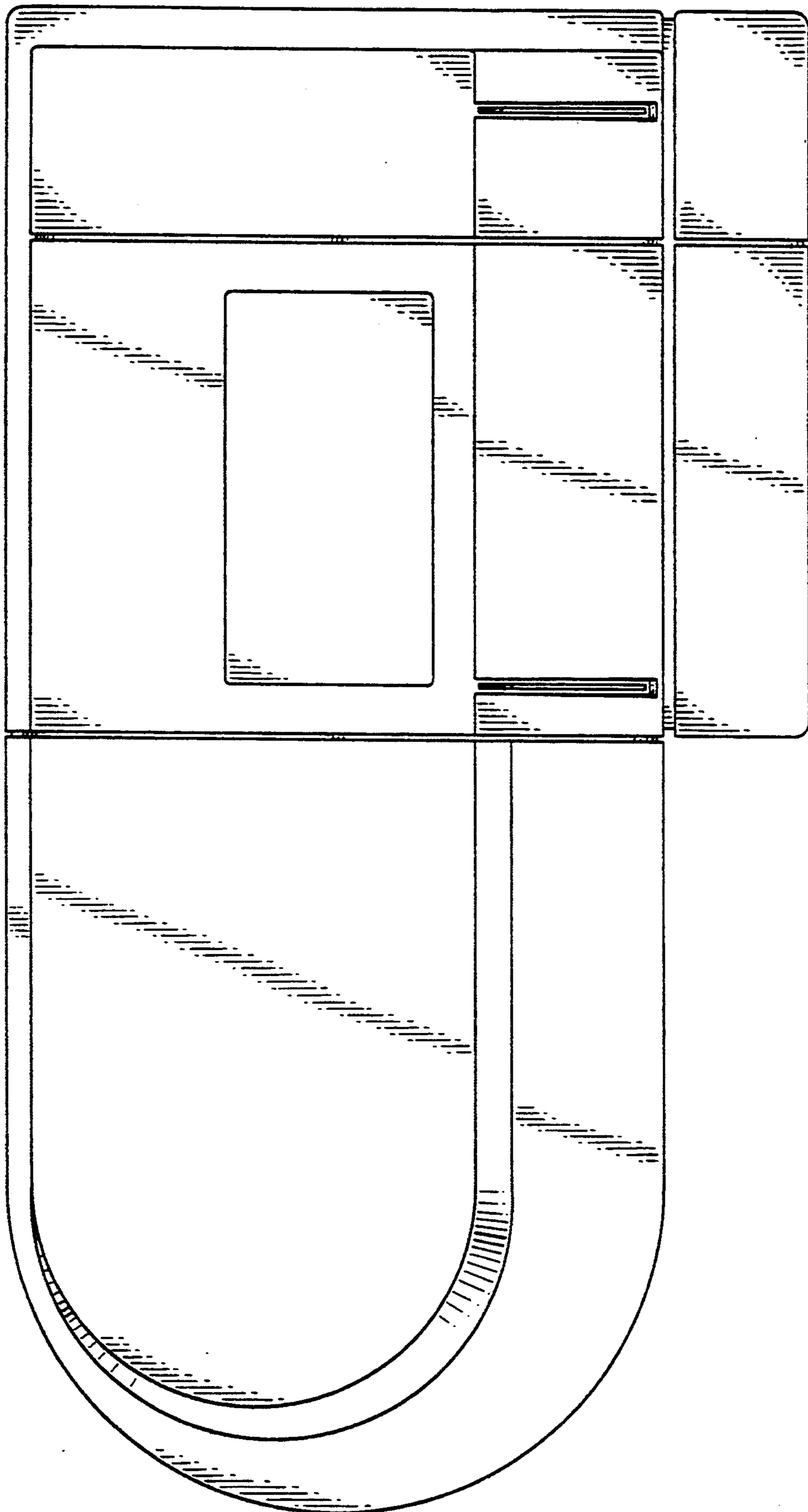

FIG. 6