



US00D355635S

United States Patent [19]

[11] Patent Number: Des. 355,635

Raisbeck

[45] Date of Patent: ** Feb. 21, 1995

[54] AIRCRAFT AFT FUSELAGE STOWAGE LOCKER

4,256,012 3/1981 Cowart et al. 244/137.3

[76] Inventor: James D. Raisbeck, 7536 Seward Park Ave. South, Seattle, Wash. 98118

Primary Examiner—Kay H. Chin
Attorney, Agent, or Firm—Christensen, O'Connor, Johnson & Kindness

[**] Term: 14 Years

[57] CLAIM

The ornamental design for an aircraft aft fuselage stowage locker, as shown and described.

[21] Appl. No.: 5,438

DESCRIPTION

[22] Filed: Mar. 3, 1993

[52] U.S. Cl. D12/345

[58] Field of Search D12/345; 244/117 R, 244/137.1, 137.3, 119, 118.1

FIG. 1 is a perspective view of an aircraft aft fuselage stowage locker showing my new design as installed on the aft fuselage of an aircraft, which is shown in broken lines for illustrative purposes only;

FIG. 2 is a bottom plan view thereof;

FIG. 3 is a left side, elevational view of my new design, the right side elevational view being a mirror image thereof; and,

FIG. 4 is a rear elevational view thereof.

[56] References Cited

U.S. PATENT DOCUMENTS

D. 149,555 5/1948 Hibbard D12/345
4,165,810 8/1979 Young 244/137.3

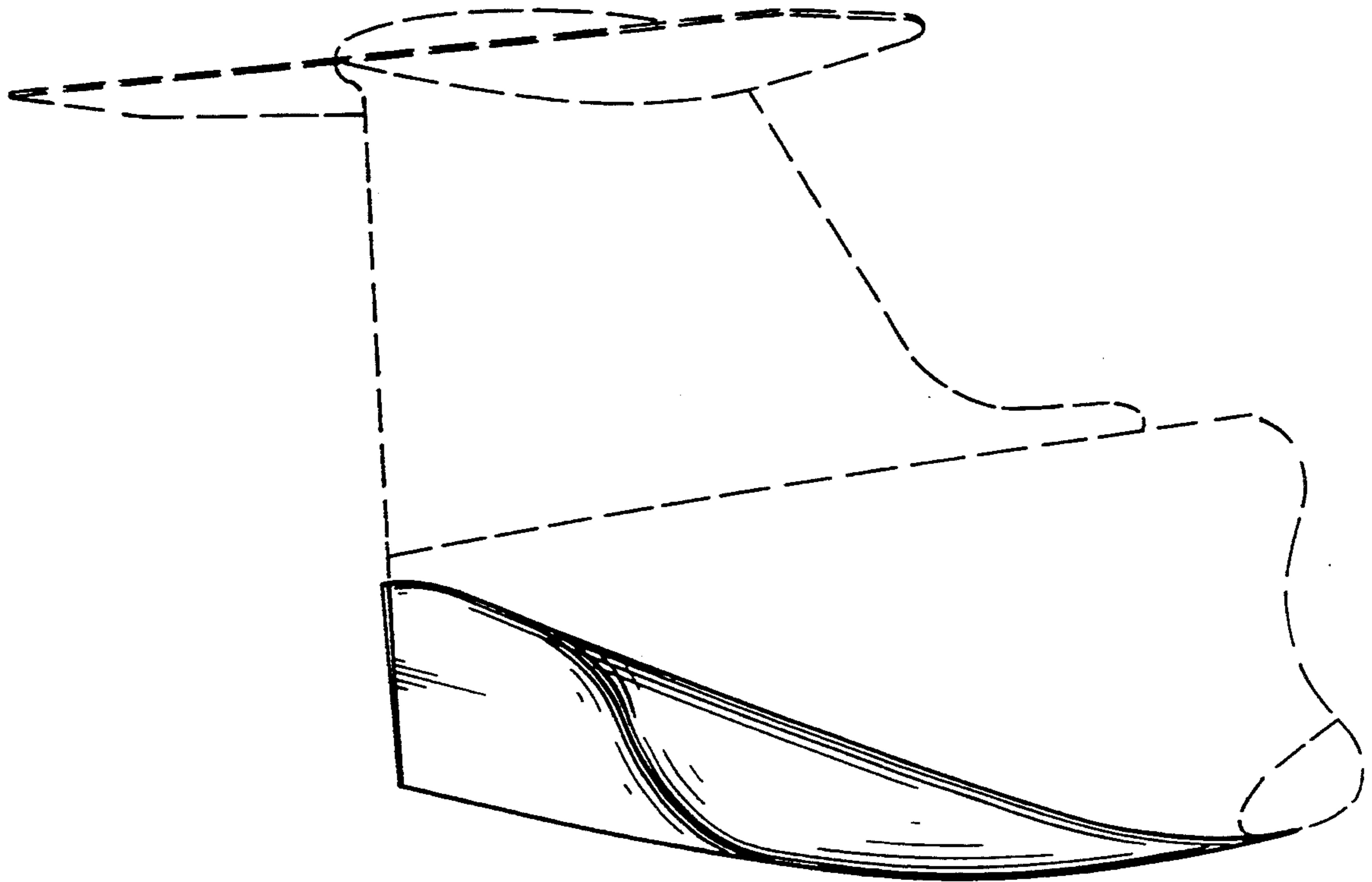
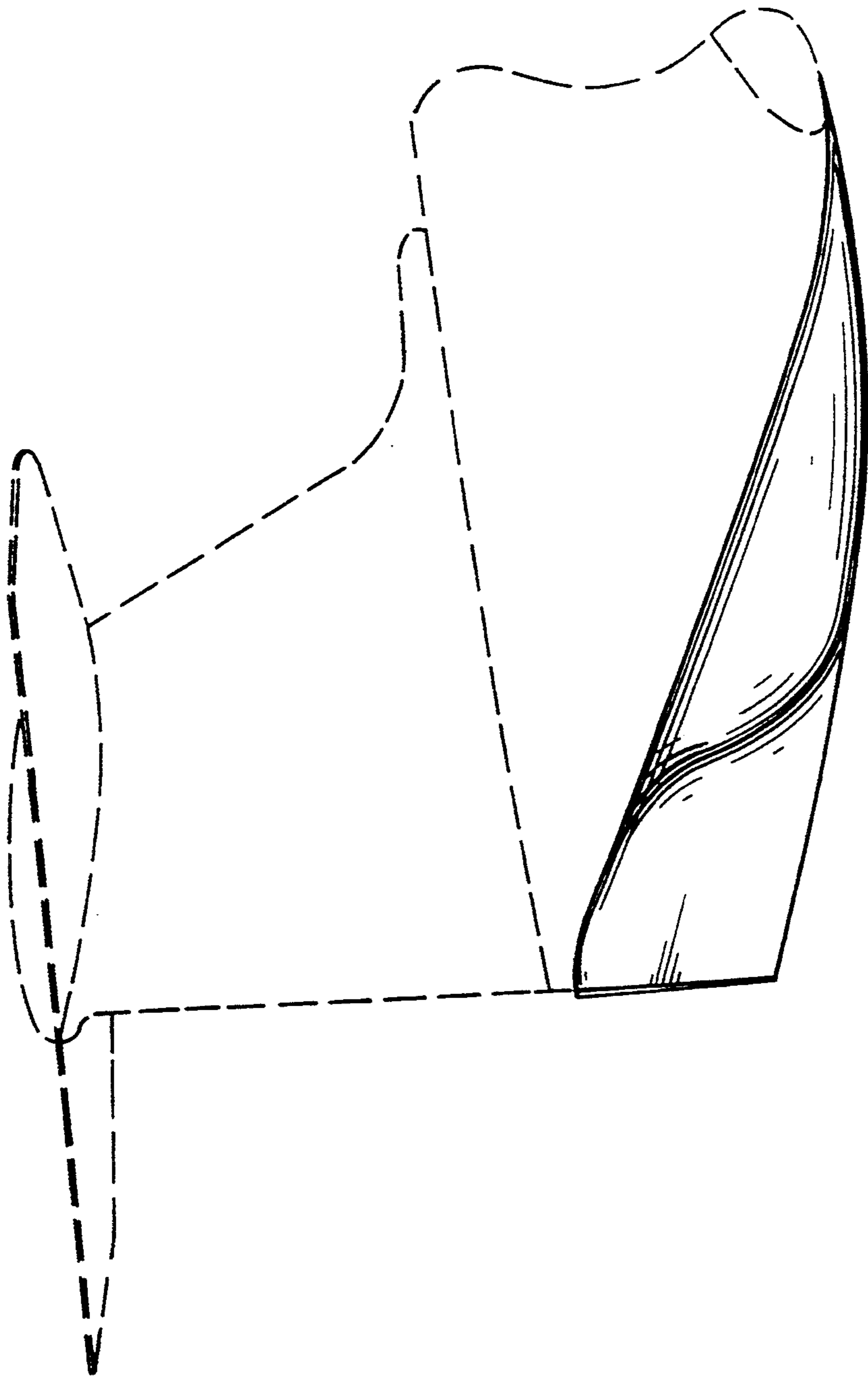

Fig. 1.



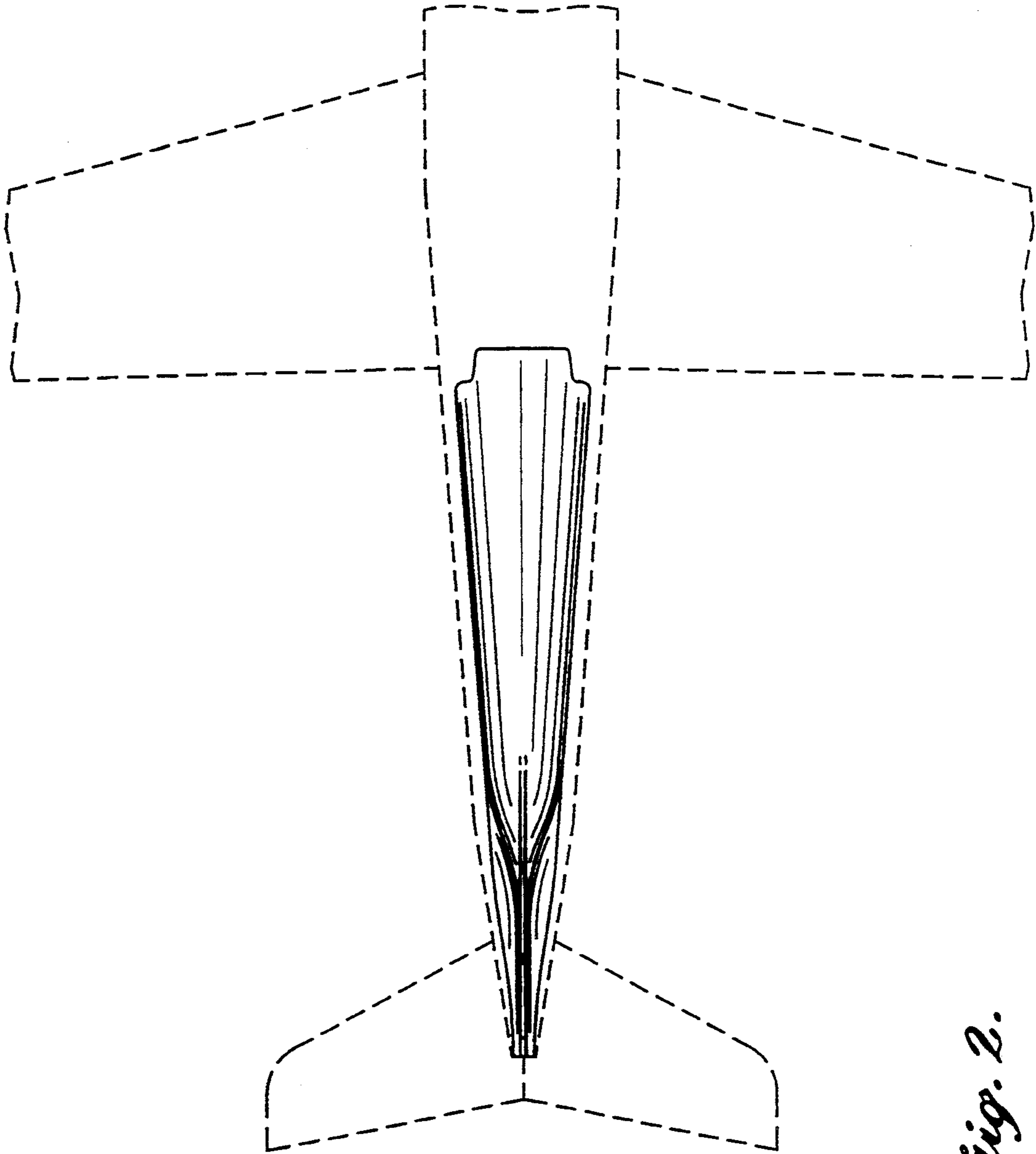

Fig. 2.

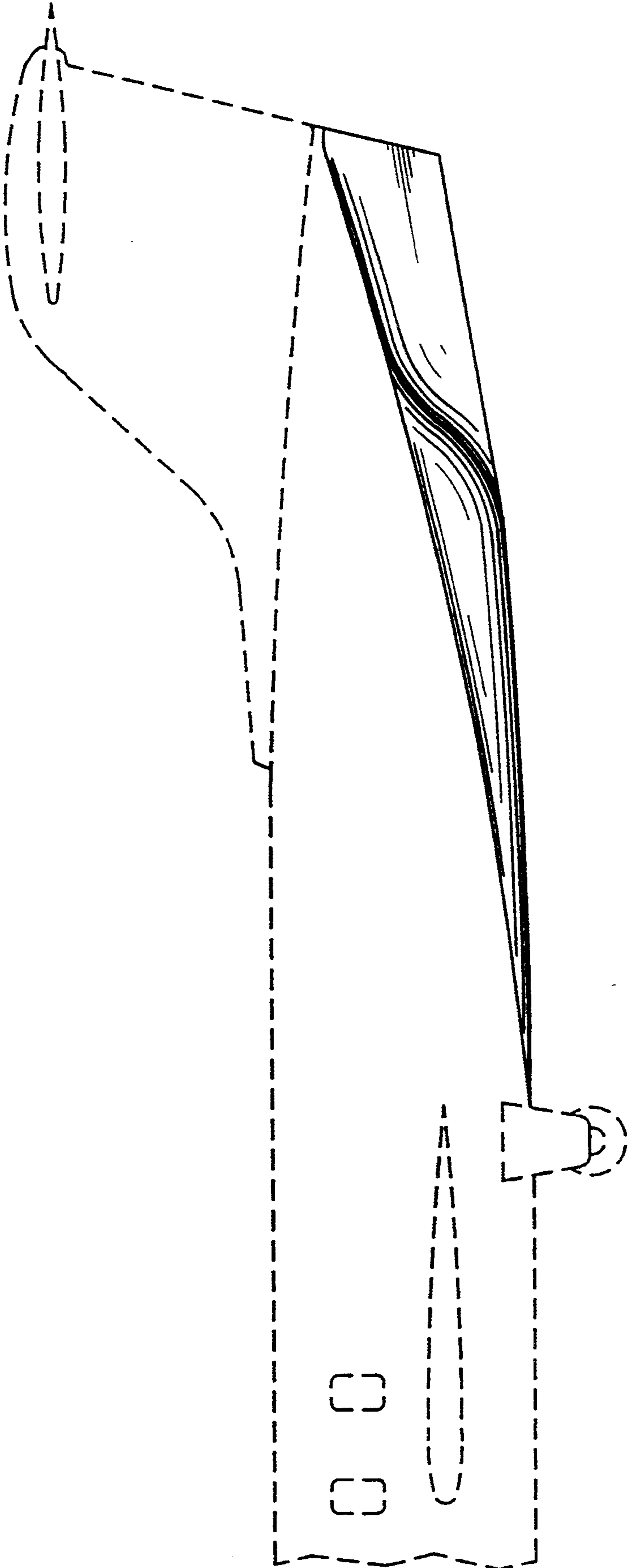

Fig. 3.

Fig. 4.

