



US00D355481S

# United States Patent [19]

[11] Patent Number: **Des. 355,481**

**Keen**

[45] Date of Patent: **\*\* Feb. 14, 1995**

[54] **COMBINED TOILET SEAT AND EXHAUST FAN**

4,165,544 8/1979 Barry ..... 4/216 X  
4,175,293 11/1979 Stephens et al. .... 4/217 X  
4,365,361 12/1982 Sanstrom .

[76] Inventor: **Eric Keen, R.R. 2 Box 303, Knox, Ind. 46534**

*Primary Examiner*—A. Hugo Word  
*Assistant Examiner*—Eric Watterson  
*Attorney, Agent, or Firm*—Terry M. Gernstein

[\*\*] Term: **14 Years**

[21] Appl. No.: **10,917**

[57] **CLAIM**

[22] Filed: **Jul. 22, 1993**

The ornamental design for a combined toilet seat and exhaust fan, as shown and described.

[52] U.S. Cl. .... **D23/311**

[58] Field of Search ..... D23/311, 312, 309;  
4/209 R, 237, 238, 242.1, 234, 216, 215, 661,  
351, 348

**DESCRIPTION**

[56] **References Cited**

**U.S. PATENT DOCUMENTS**

- D. 215,937 11/1969 Meyer ..... D23/311
- D. 338,712 8/1993 Schaldenbrand ..... D23/311
- 1,513,168 5/1922 Frick ..... 4/217
- 2,696,619 12/1954 Ring .
- 3,277,499 10/1966 Keefauver .
- 3,733,619 5/1973 Smith ..... 4/217

FIG. 1 is a front, top and side perspective view of the combined toilet seat and exhaust fan showing my new design, the exhaust conduit is broken away to show indeterminate length;

- FIG. 2 is a front elevational view thereof;
- FIG. 3 is a rear elevational view thereof;
- FIG. 4 is a side elevational view thereof;
- FIG. 5 is a side elevational view thereof;
- FIG. 6 is a top plan view thereof; and,
- FIG. 7 is a bottom plan view thereof.

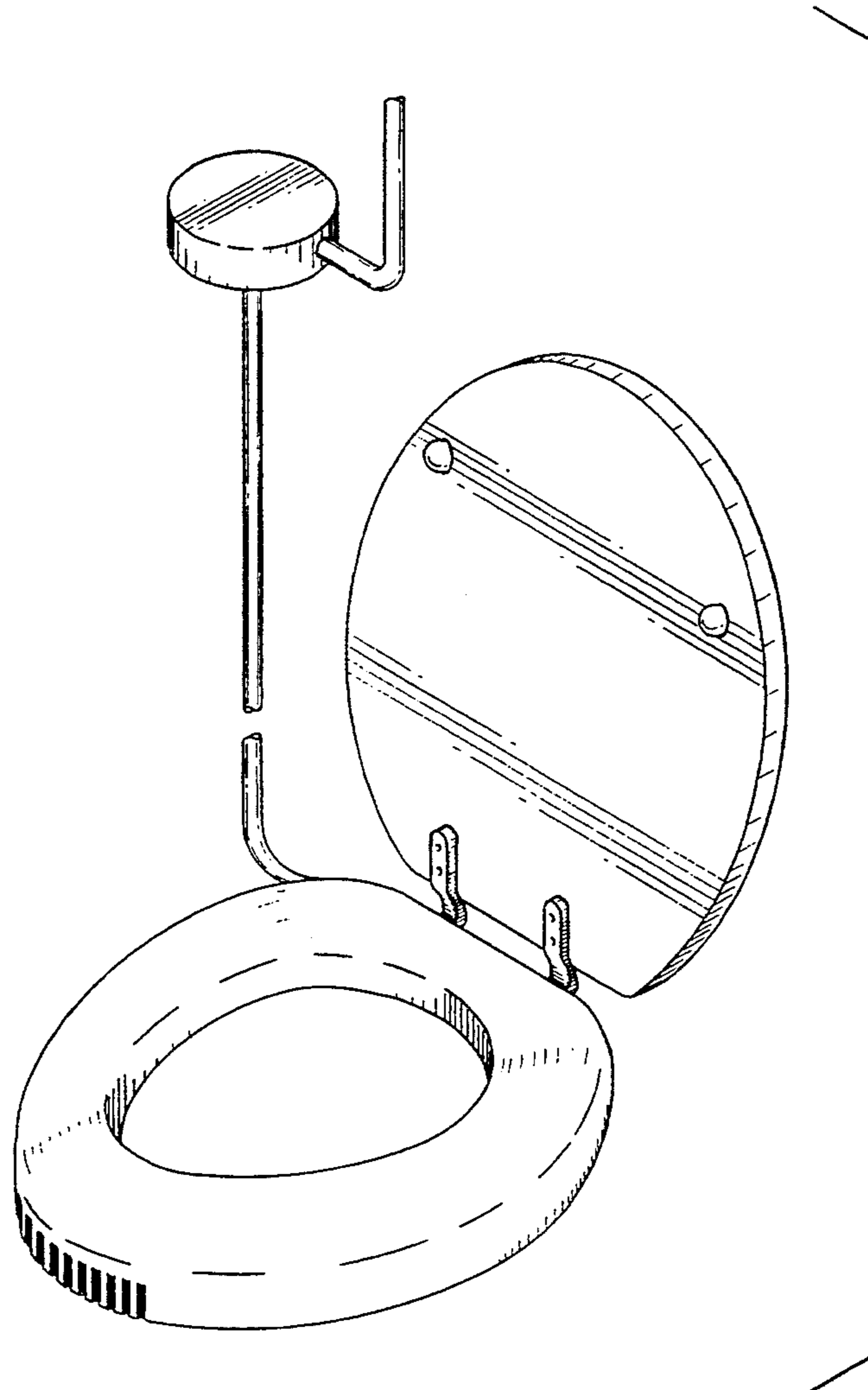

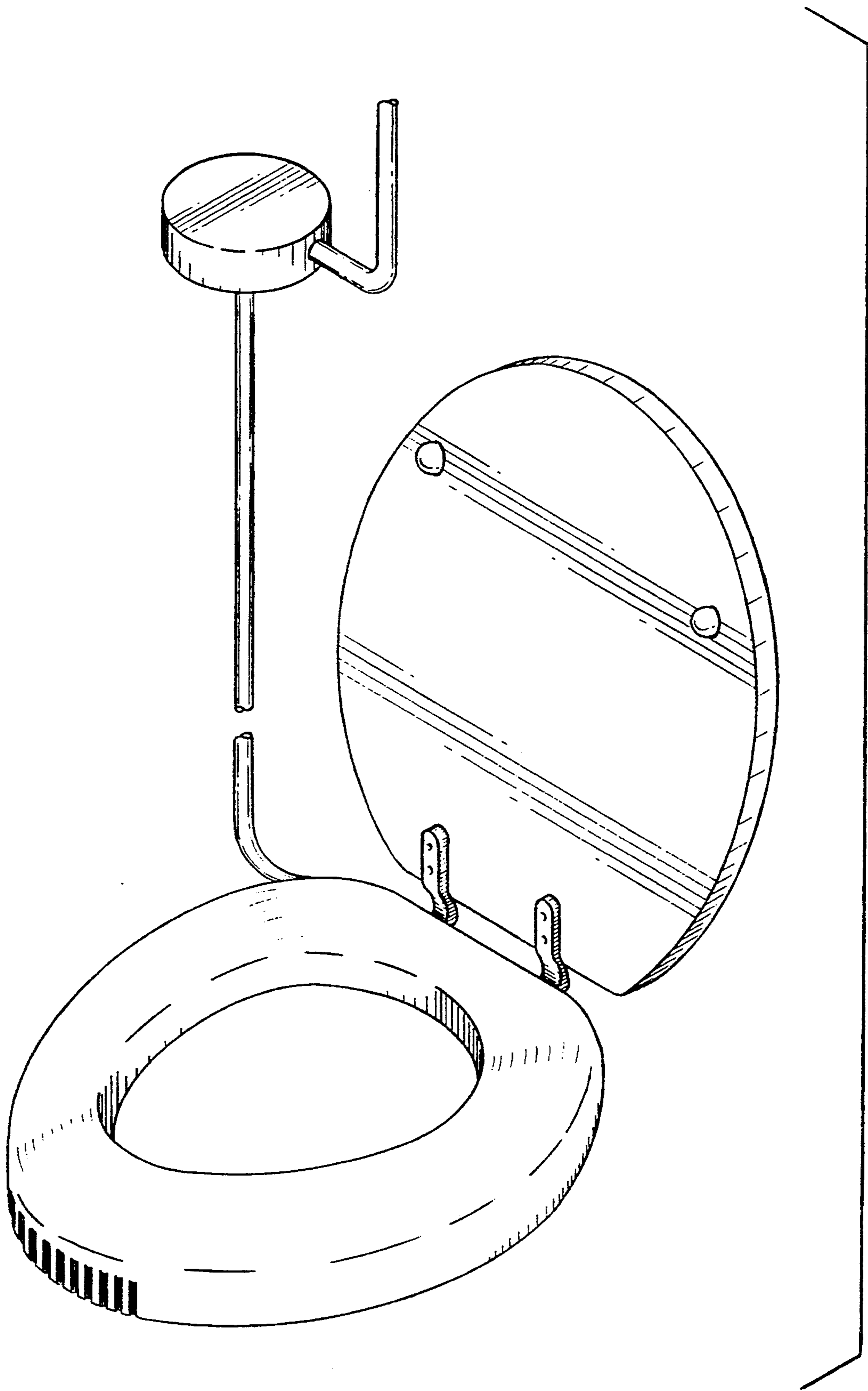

FIG. 1

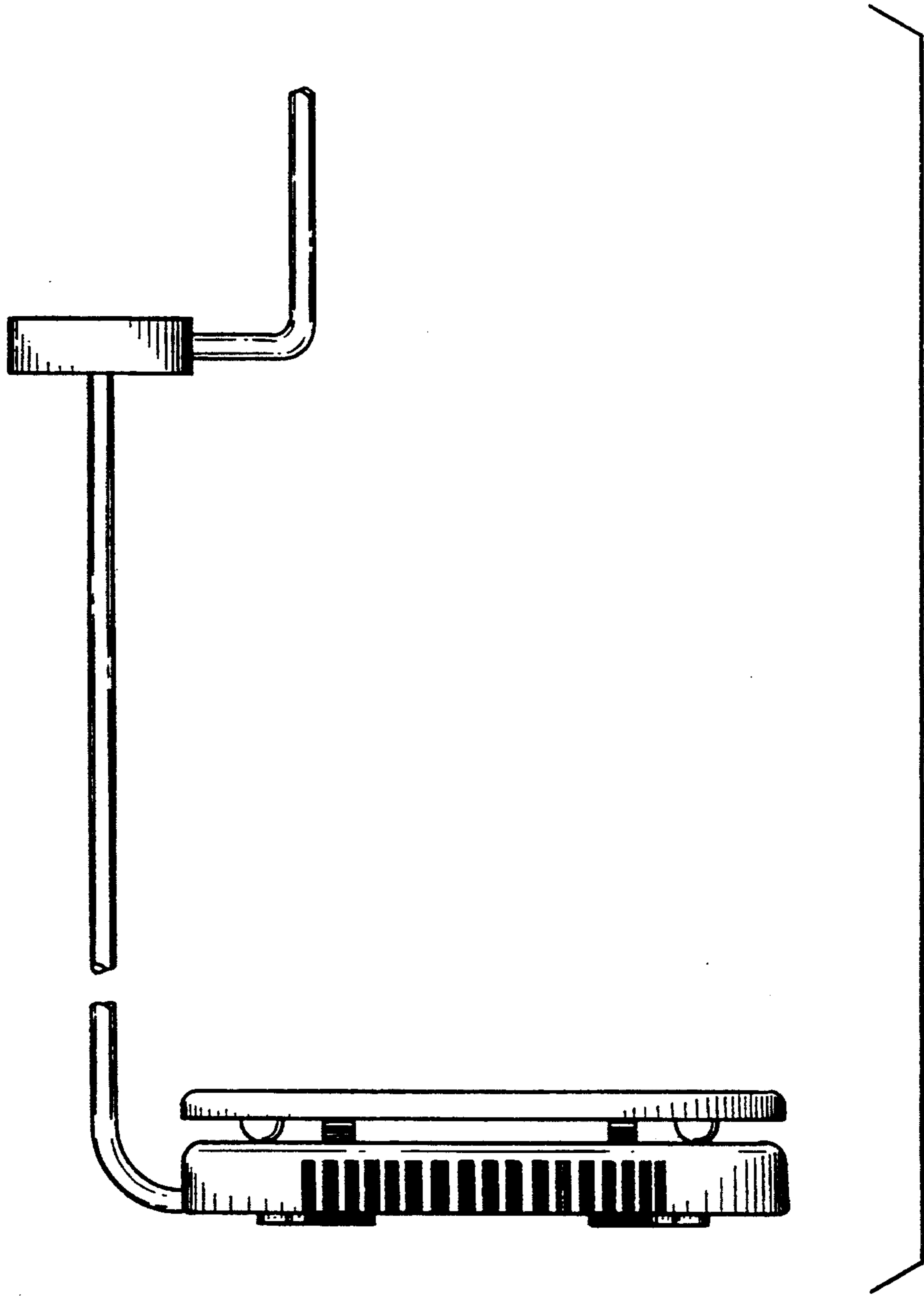

FIG. 2

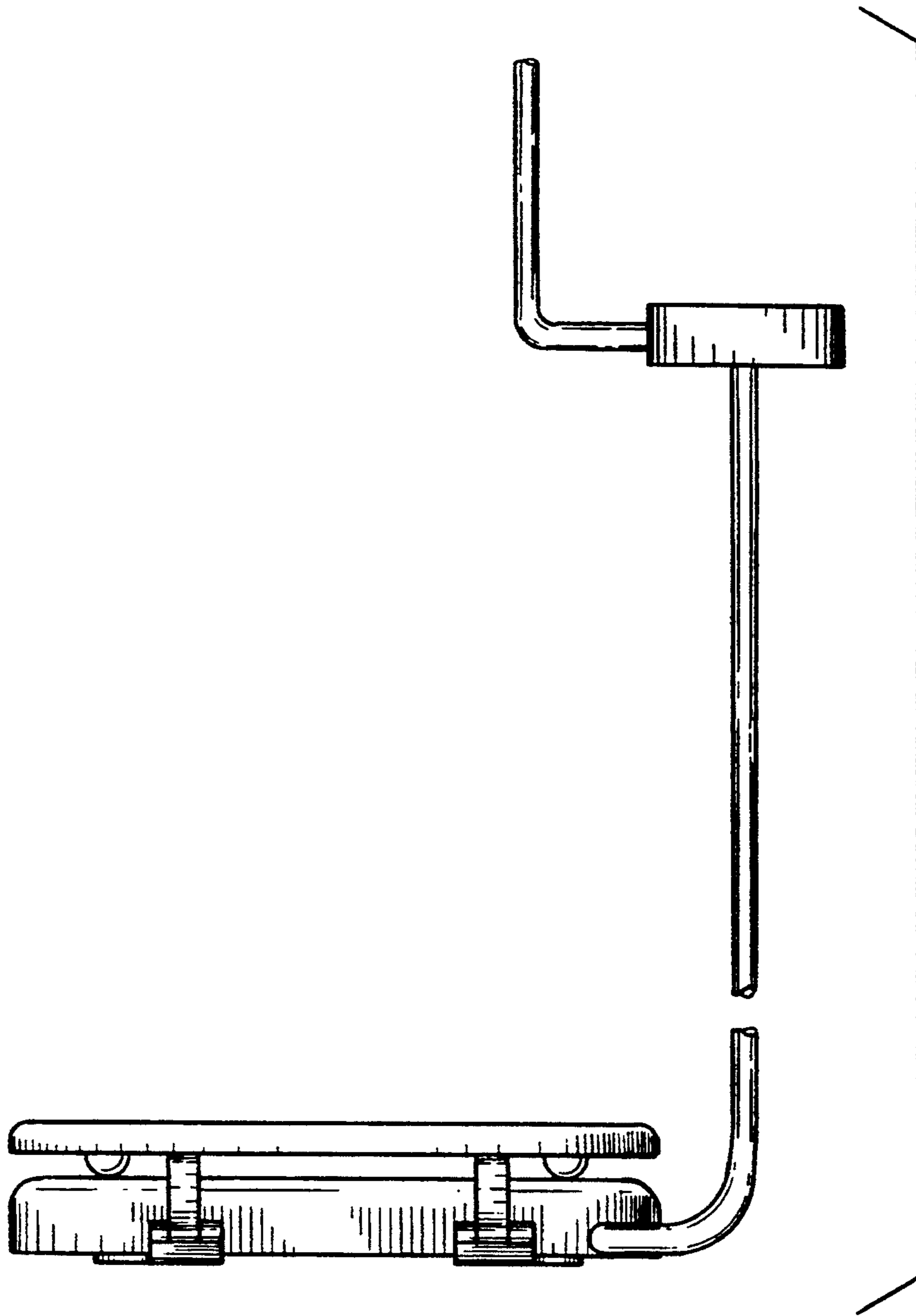

FIG. 3

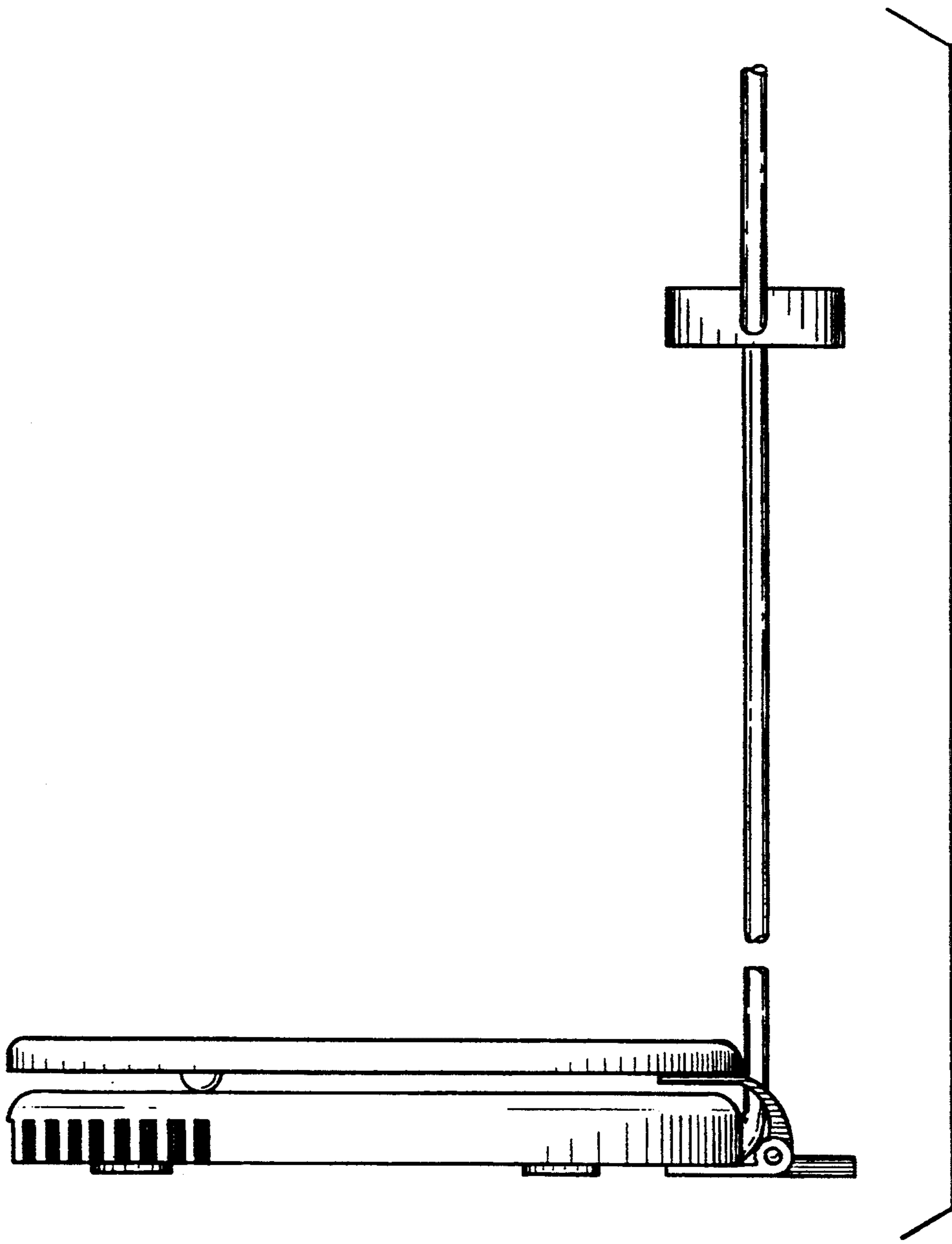

FIG. 4

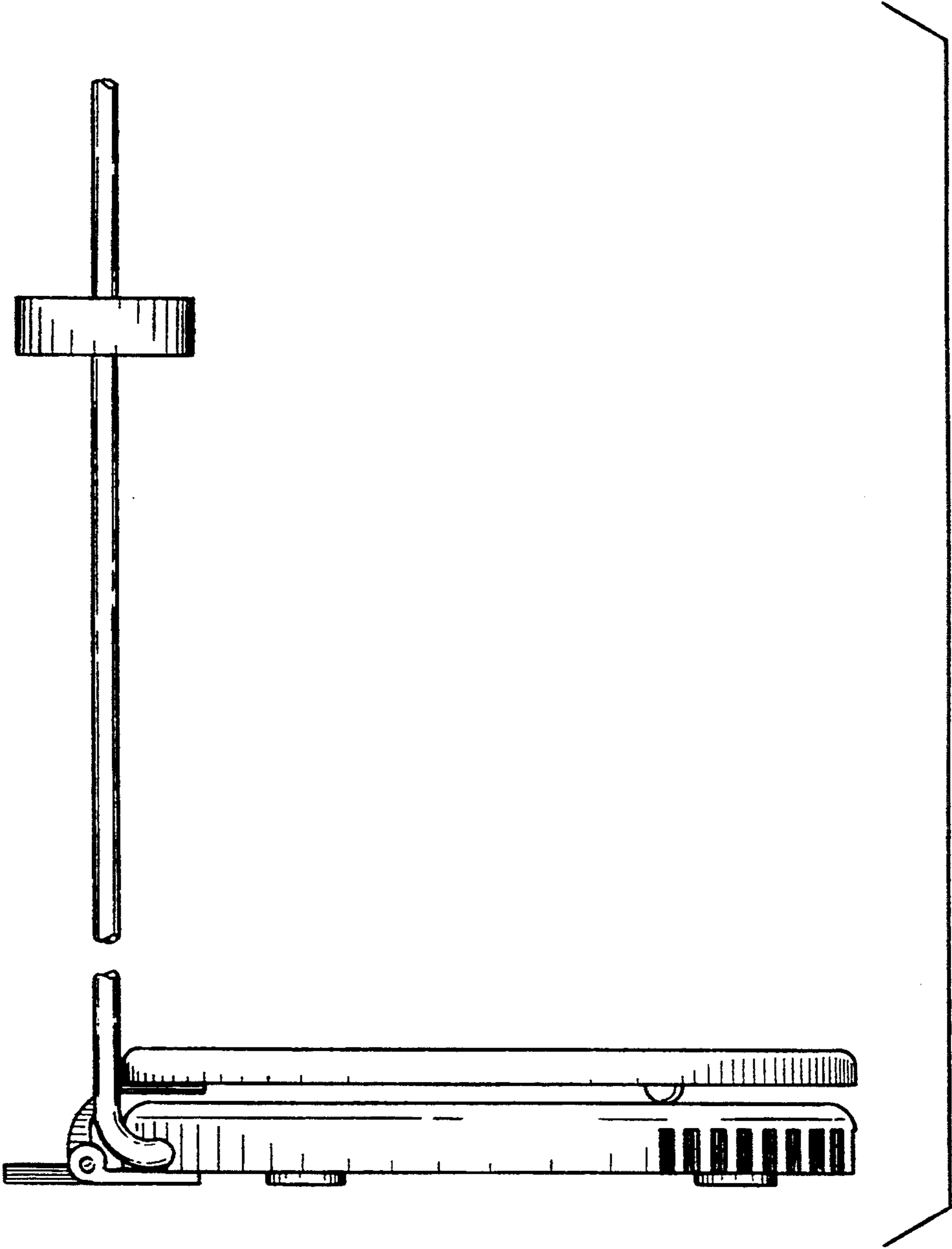

FIG. 5

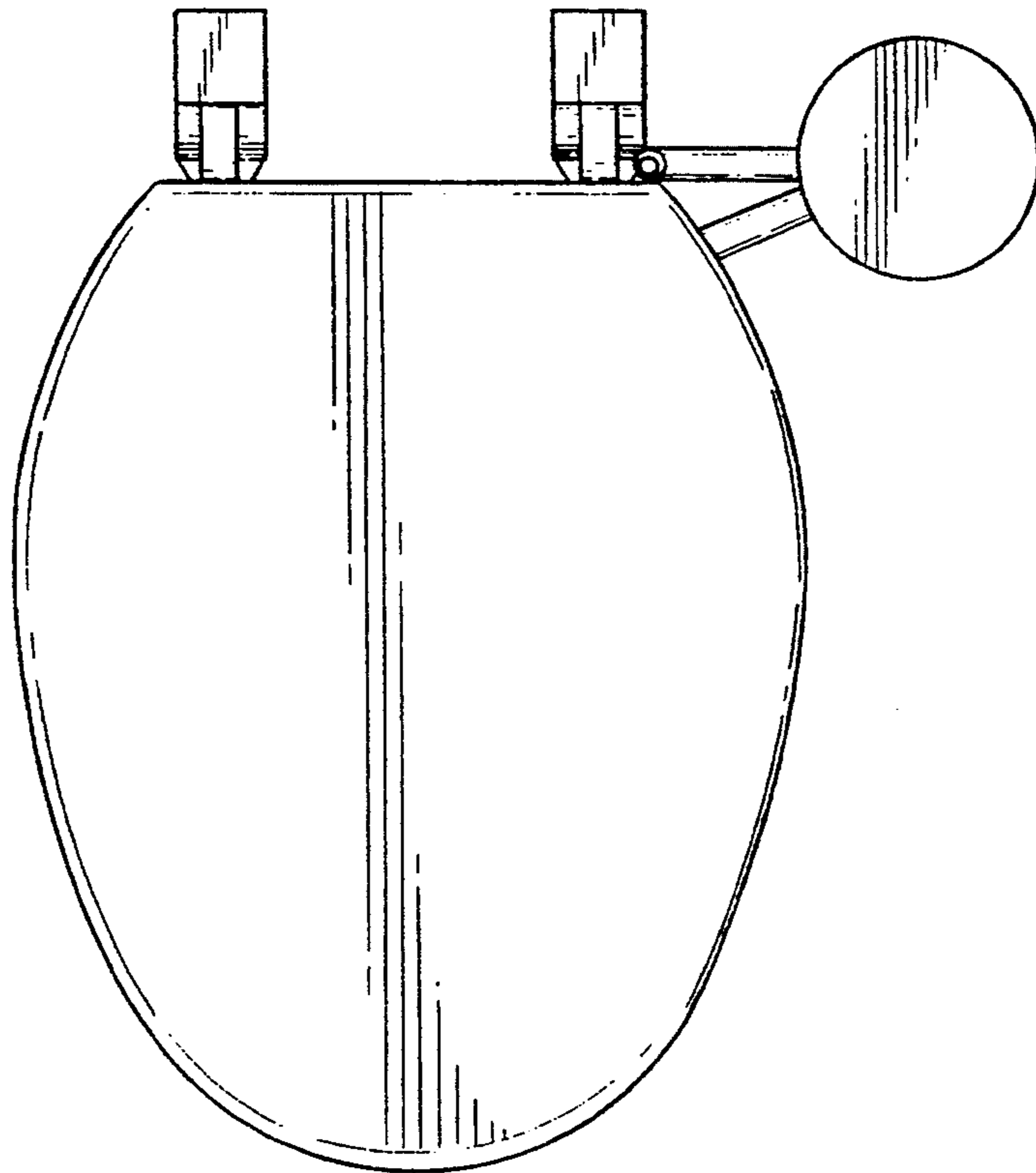

FIG. 6

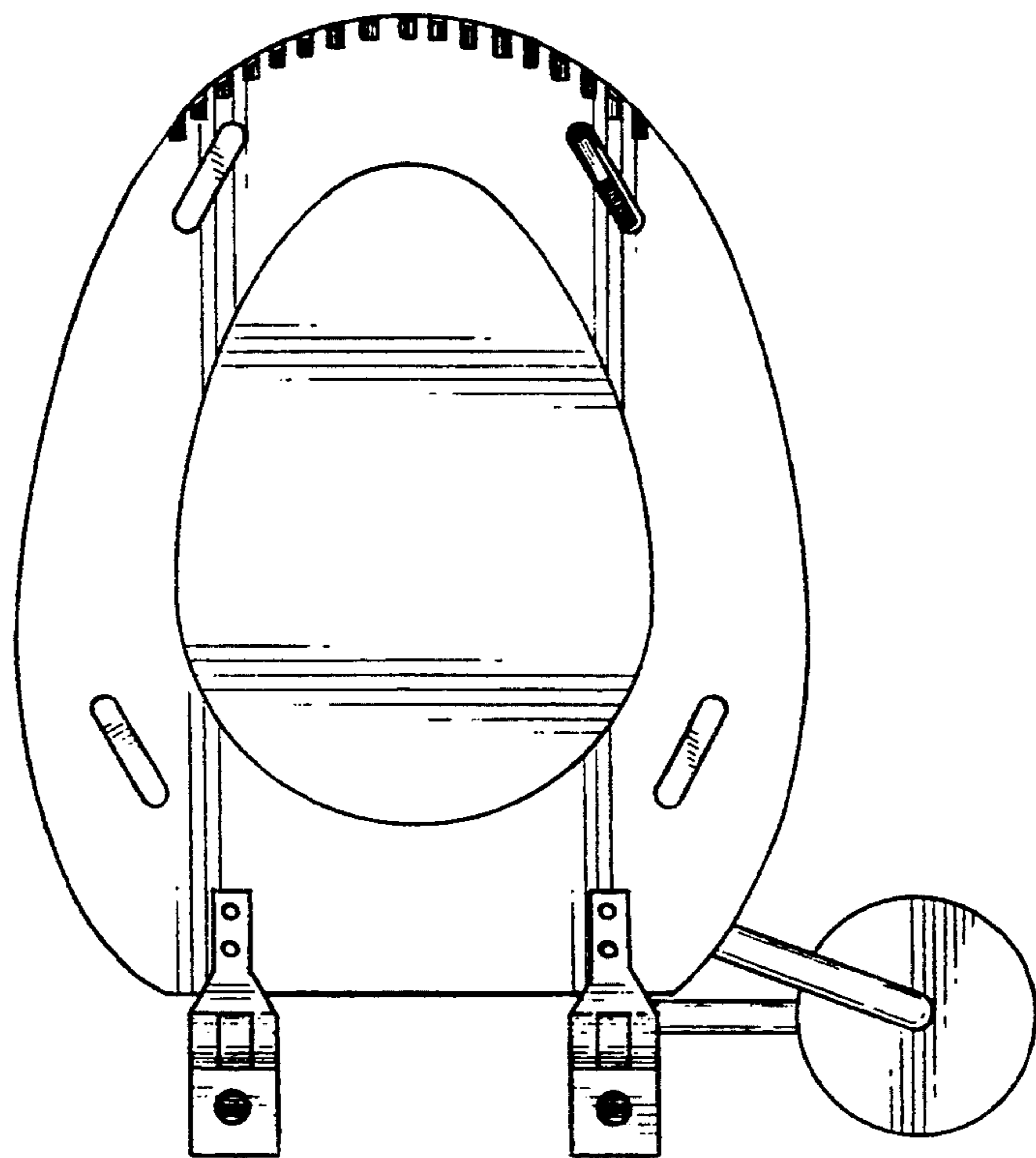

FIG. 7