



US00D355439S

United States Patent [19]
Hollington

[11] **Patent Number: Des. 355,439**
[45] **Date of Patent: ** Feb. 14, 1995**

[54] **WRITING INSTRUMENT**

- [75] Inventor: **Geoffrey A. Hollington**, London, England
- [73] Assignee: **Parker Pen (Benelux) B.V.**, Netherlands
- [*] Notice: The portion of the term of this patent subsequent to Aug. 17, 2007 has been disclaimed.
- [**] Term: **14 Years**
- [21] Appl. No.: **4,369**
- [22] Filed: **Feb. 3, 1993**
- [52] U.S. Cl. **D19/43; D19/50; D19/51; D19/57**
- [58] Field of Search **D19/35, 36, 41-51, D19/54-58, 81-85; 401/99, 100, 101, 102, 103, 104, 209, 221, 222, 243-247**

[56] **References Cited**

U.S. PATENT DOCUMENTS

- D. 78,794 6/1929 Sheaffer D19/36
- D. 88,821 12/1932 Platt et al. D19/56
- D. 330,217 10/1992 Booker D19/51 X
- D. 338,491 9/1993 Hollington D19/50

Primary Examiner—Martie Thompson
Attorney, Agent, or Firm—Andrus, Scales, Starke & Sawall

[57] **CLAIM**

The ornamental design for a writing instrument, as shown.

DESCRIPTION

FIG. 1 is a perspective view of a writing instrument incorporating my new design;
 FIG. 2 is a front elevational view of the writing instrument of FIG. 1;
 FIG. 3 is a rear elevational view of the writing instrument of FIG. 1;
 FIG. 4 is a left side, elevational view of the writing instrument of FIG. 1;
 FIG. 5 is a top view of the writing instrument of FIG. 1;

FIG. 6 is a bottom view of the writing instrument of FIG. 1;
 FIG. 7 is perspective view of a writing instrument incorporating a second embodiment of my new design;
 FIG. 8 is a front elevational view of the writing instrument of FIG. 7;
 FIG. 9 is a rear elevational view of the writing instrument of FIG. 7;
 FIG. 10 is a left side, elevational view of the writing instrument of FIG. 7;
 FIG. 11 is a top view of the writing instrument of FIG. 7;
 FIG. 12 is a bottom view of the writing instrument of FIG. 7;
 FIG. 13 is a perspective view of a writing instrument incorporating a third embodiment of my new design;
 FIG. 14 is a left side elevational view of the writing instrument of FIG. 13 in an exploded condition;
 FIG. 15 is a front elevational view of the writing instrument of FIG. 13;
 FIG. 16 is a rear elevational view of the writing instrument of FIG. 13;
 FIG. 17 is a left side, elevational view of the writing instrument of FIG. 13;
 FIG. 18 is a top view of the writing instrument of FIG. 13;
 FIG. 19 is a bottom view of the writing instrument of FIG. 13;
 FIG. 20 is a perspective view of a writing instrument incorporating a fourth embodiment of my new design;
 FIG. 21 is a left side elevational view of the writing instrument of FIG. 20 in an exploded condition;
 FIG. 22 is a front elevational view of the writing instrument of FIG. 20;
 FIG. 23 is a rear elevational view of the writing instrument of FIG. 20;
 FIG. 24 is a left side, elevational view of the writing instrument of FIG. 20;
 FIG. 25 is a top view of the writing instrument of FIG. 20; and,
 FIG. 26 is a bottom view of the writing instrument of FIG. 20.

The characteristic feature of the design resides in the particularly configured clip member in combination with the writing instrument body shown, as best illustrated, in FIGS. 1, 7, and 20.



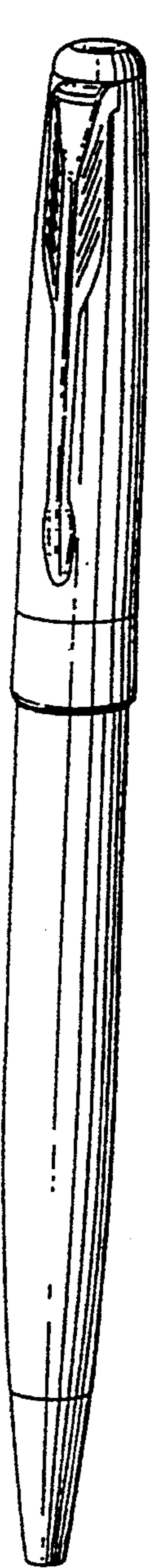

Fig. 1.



Fig. 2.

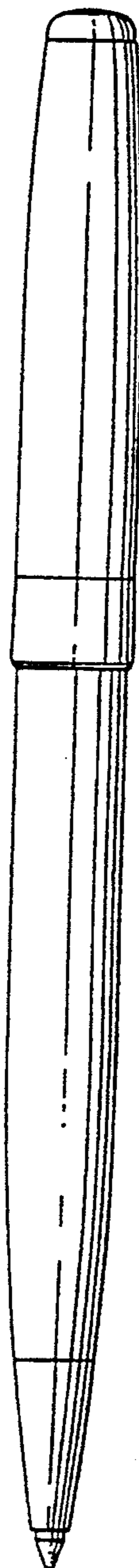

Fig. 3.

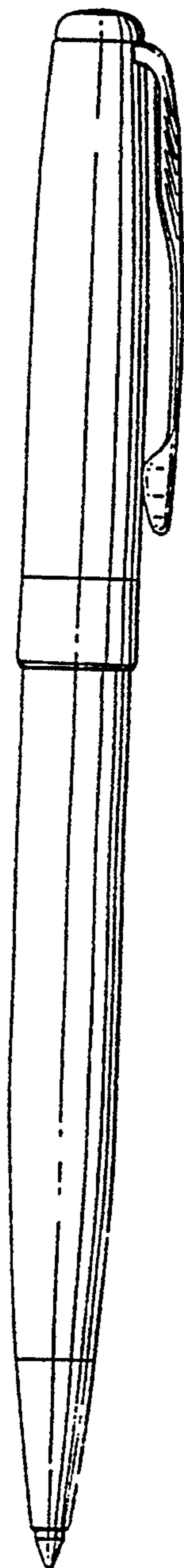

Fig. 4.



Fig. 5.

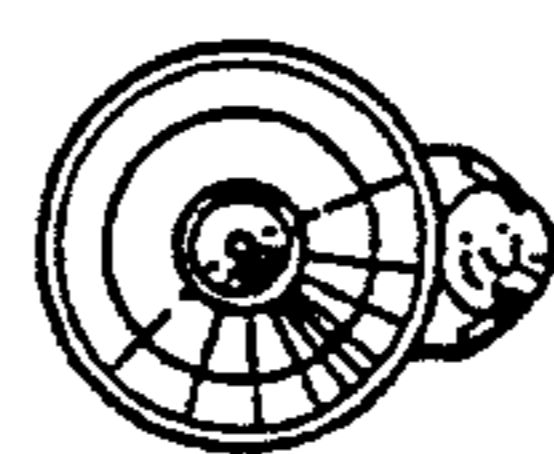

Fig. 6.

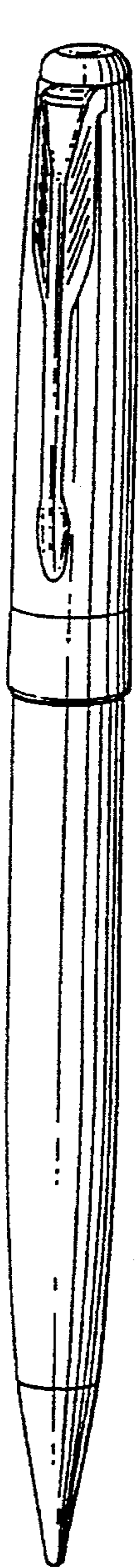

Fig. 7.

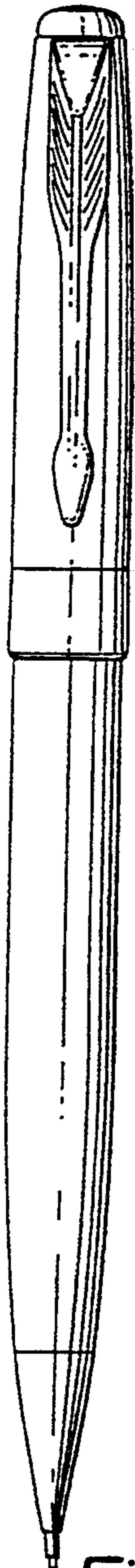

Fig. 8.

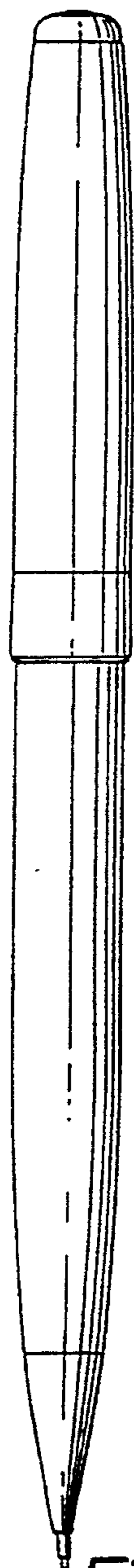

Fig. 9.

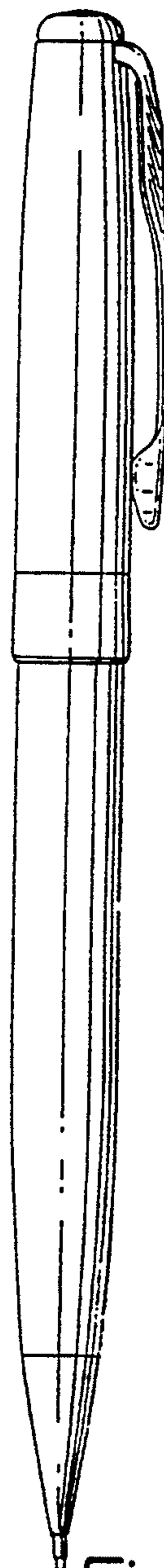

Fig. 10.

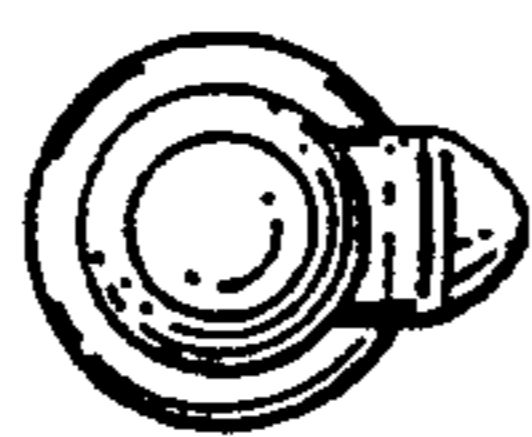

Fig. 11.

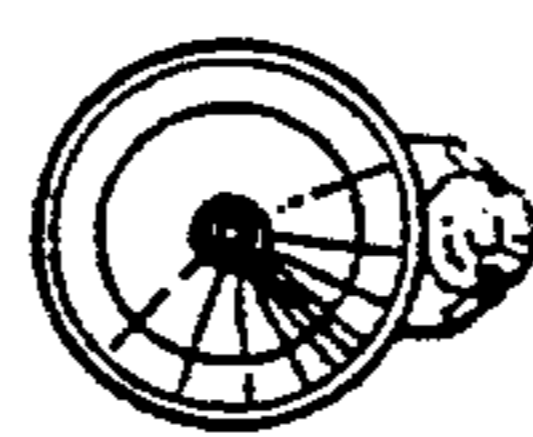

Fig. 12.

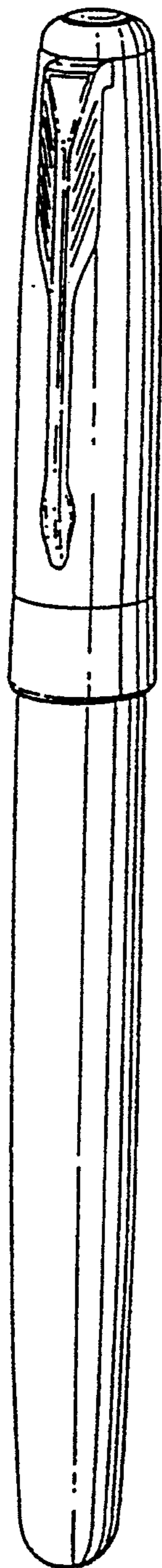

Fig. 13.

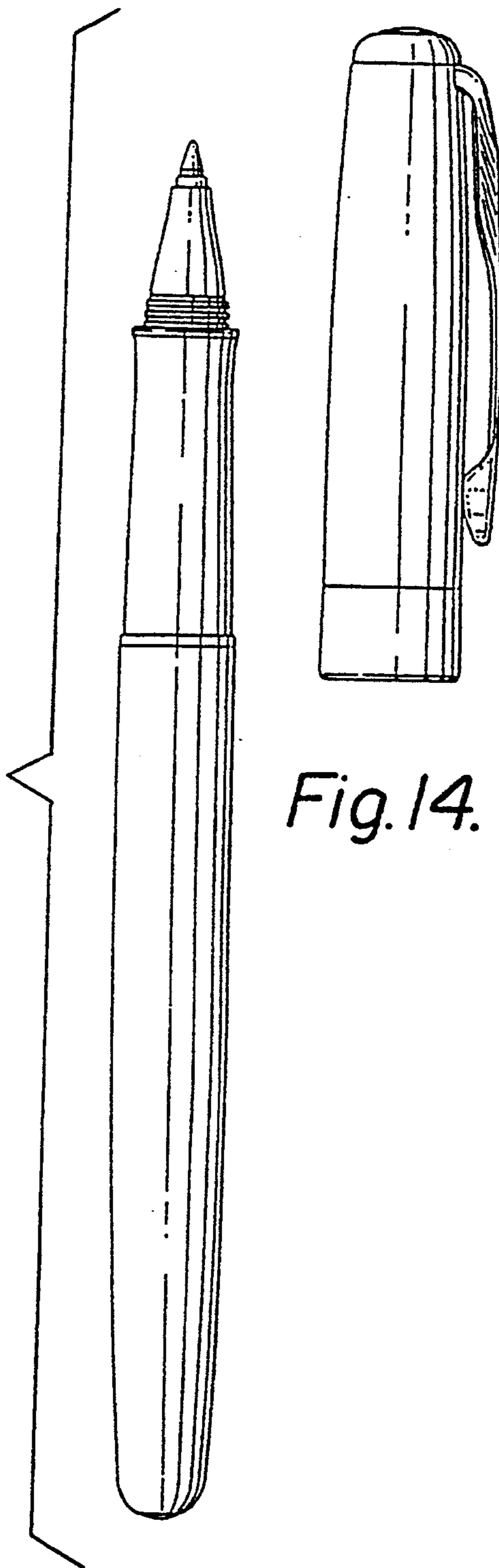

Fig. 14.

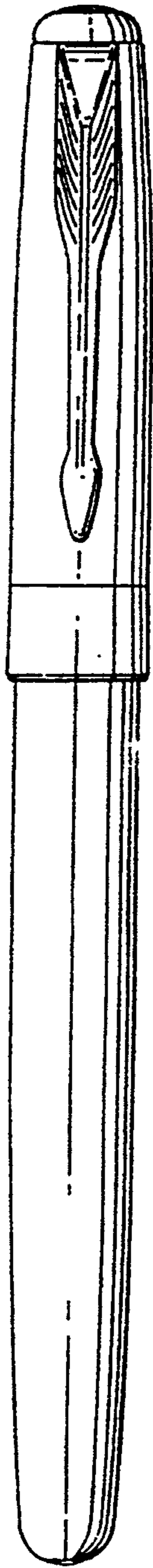

Fig. 15.

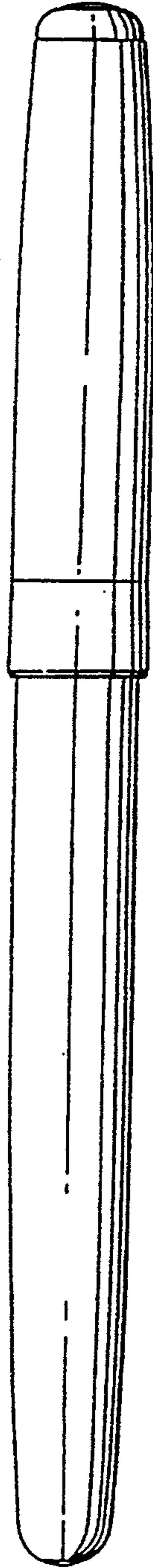

Fig. 16.

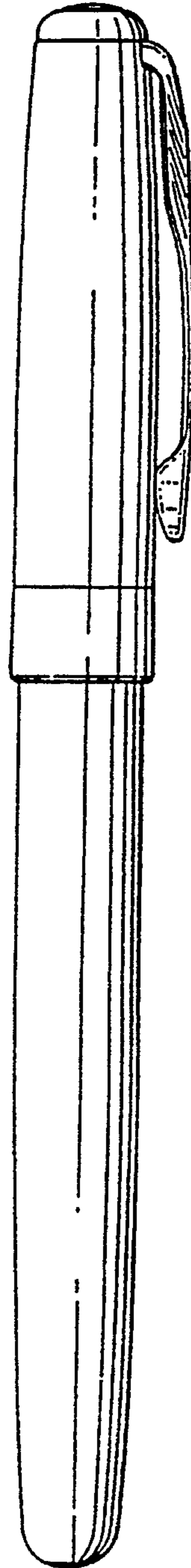

Fig. 17.

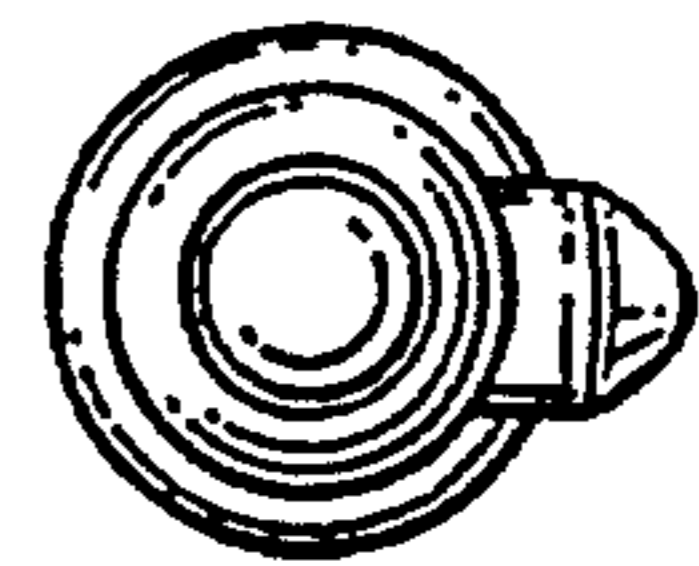

Fig. 18.

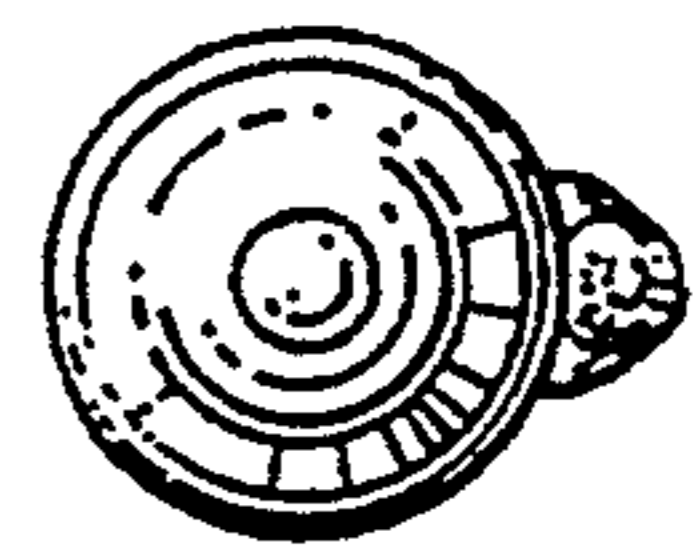

Fig. 19.

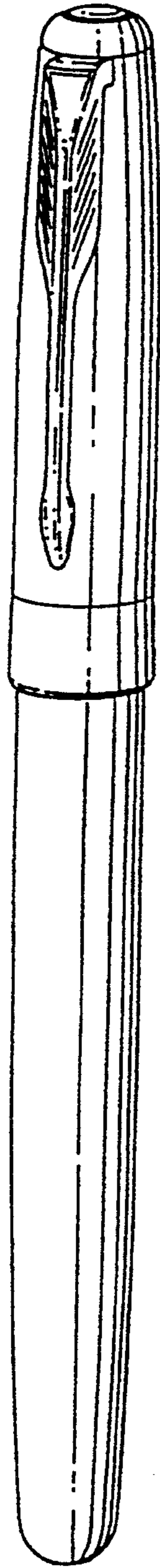

Fig. 20.

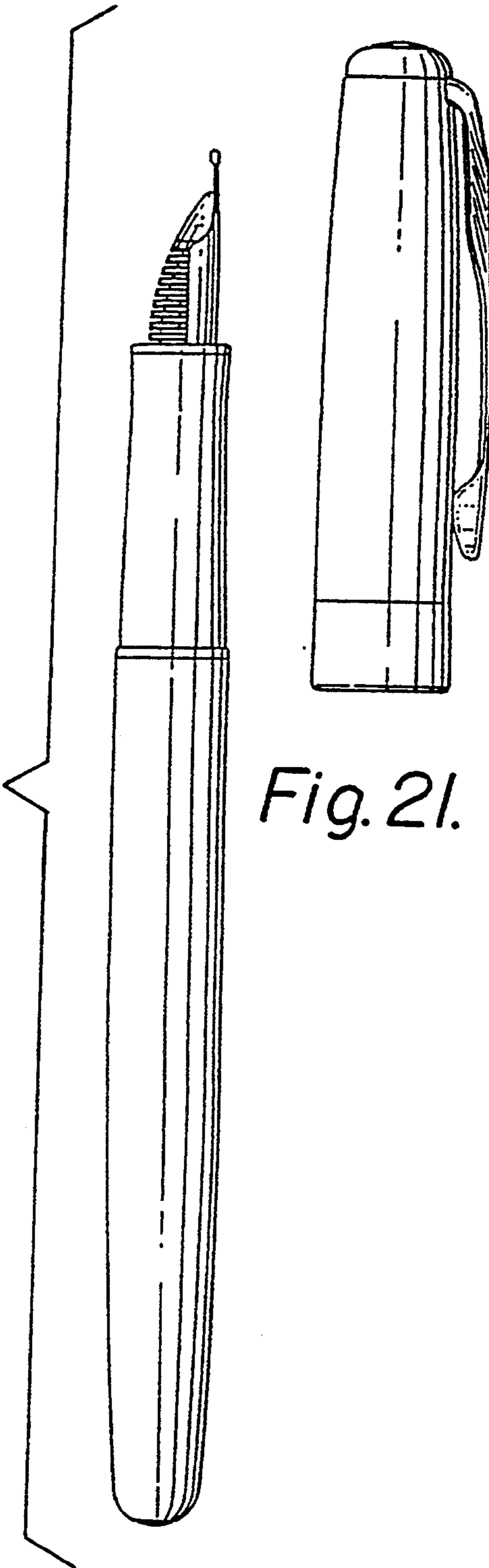

Fig. 21.

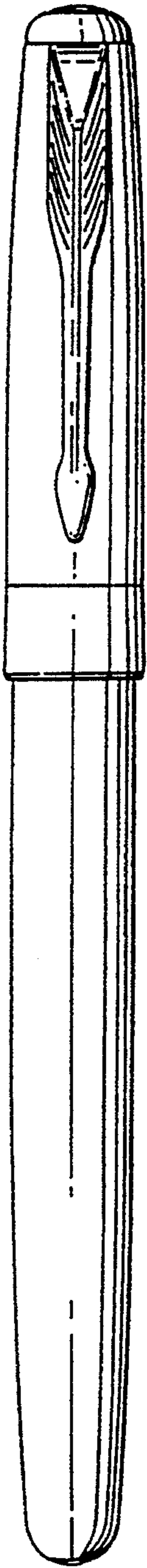

Fig. 22.

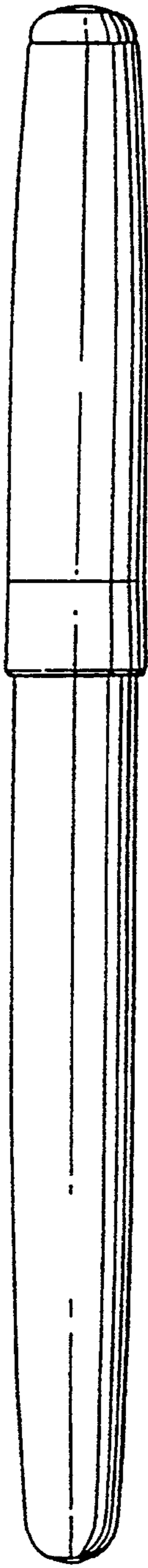

Fig. 23.

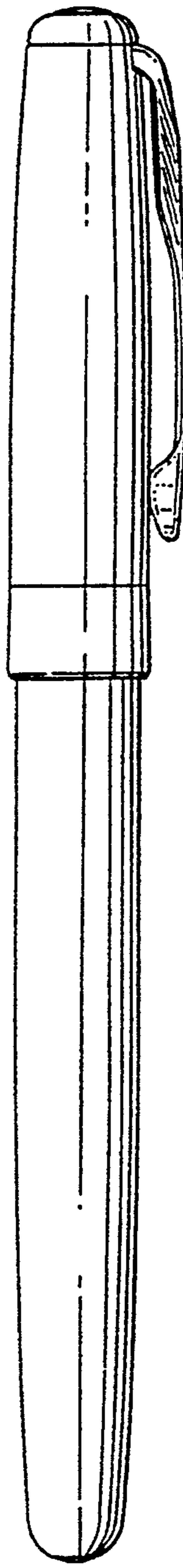

Fig. 24.

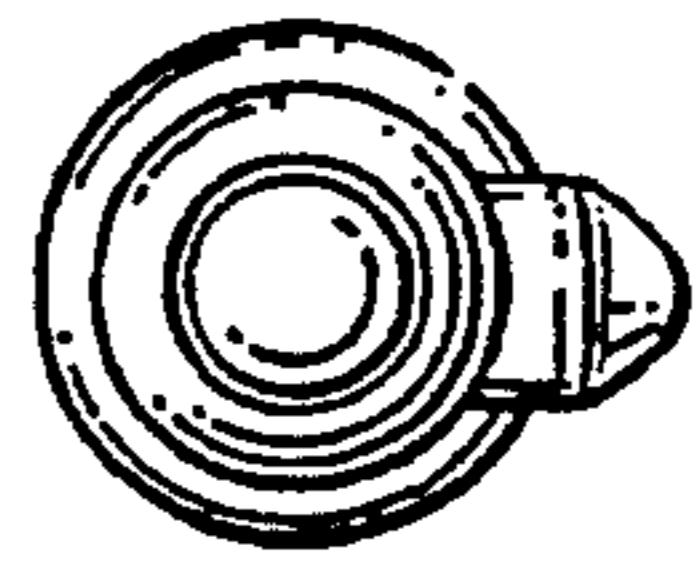

Fig. 25.

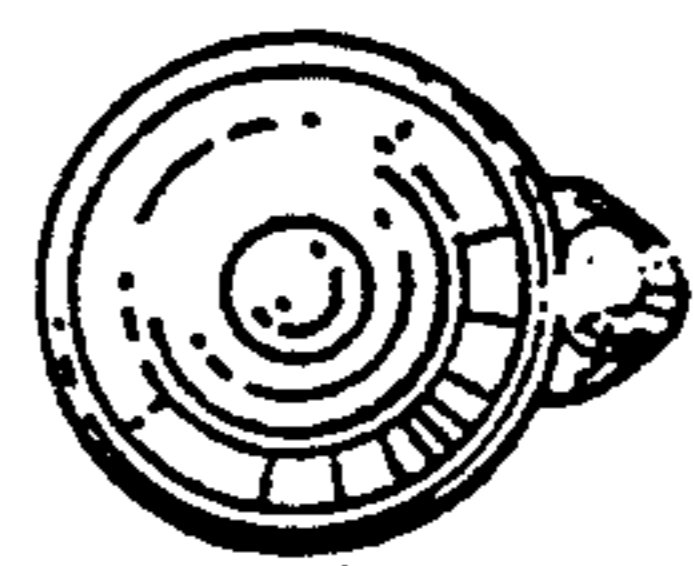

Fig. 26.