



US00D355397S

# United States Patent [19]

[11] Patent Number: **Des. 355,397**

Verduyn et al.

[45] Date of Patent: **\*\* Feb. 14, 1995**

[54] **AUTOMOBILE BODY**

D. 87,081 5/1932 Pike ..... D12/91

[75] Inventors: **Kevin R. Verduyn**, Oceanside;  
**Thomas G. Tremont**, San Diego, both  
of Calif.; **Thomas C. Gale**, Rochester;  
**K. Neil Walling**, Leonard, both of  
Mich.; **Timothy W. Anness**, San  
Diego, Calif.

*Primary Examiner*—James M. Gandy  
*Attorney, Agent, or Firm*—Mark P. Calcaterra

[73] Assignee: **Chrysler Corporation**, Highland  
Park, Mich.

[57] **CLAIM**

The ornamental design for an automobile body, as  
shown and described.

[\*\*] Term: **14 Years**

**DESCRIPTION**

[21] Appl. No.: **3,439**

FIG. 1 is a front perspective view of an automobile  
body showing our new design, it being understood that  
the broken lines are for illustrative purposes only and  
form no part of the claimed design;

[22] Filed: **Jan. 4, 1993**

FIG. 2 is a rear perspective view of the automobile  
body shown in FIG. 1;

**Related U.S. Application Data**

[63] Continuation-in-part of Ser. No. 1,540, Nov. 17, 1992.

FIG. 3 is a side elevational view of the automobile body  
shown in FIG. 1;

[52] U.S. Cl. .... **D12/92**

FIG. 4 is a side elevational view of the automobile body  
shown in FIG. 1 with the convertible ttop down;

[58] Field of Search ..... D12/91, 92; 296/185

FIG. 5 is a top perspective view of the automobile body  
shown in FIG. 1;

[56] **References Cited**

**U.S. PATENT DOCUMENTS**

D. 79,563 10/1929 Morton ..... D12/91  
D. 86,742 4/1932 Pike ..... D12/91

FIG. 6 is a front elevational view of the automobile  
body of FIG. 1; and,

FIG. 7 is a rear elevational view of the automobile body  
of FIG. 1.

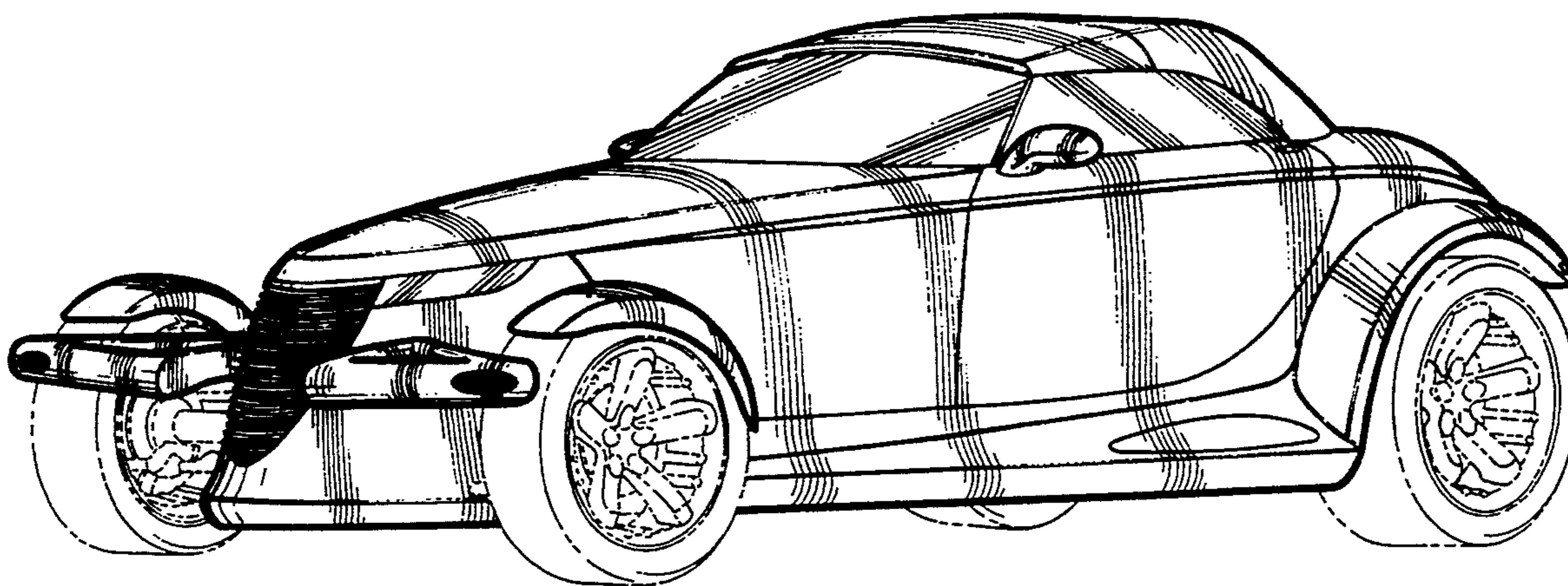

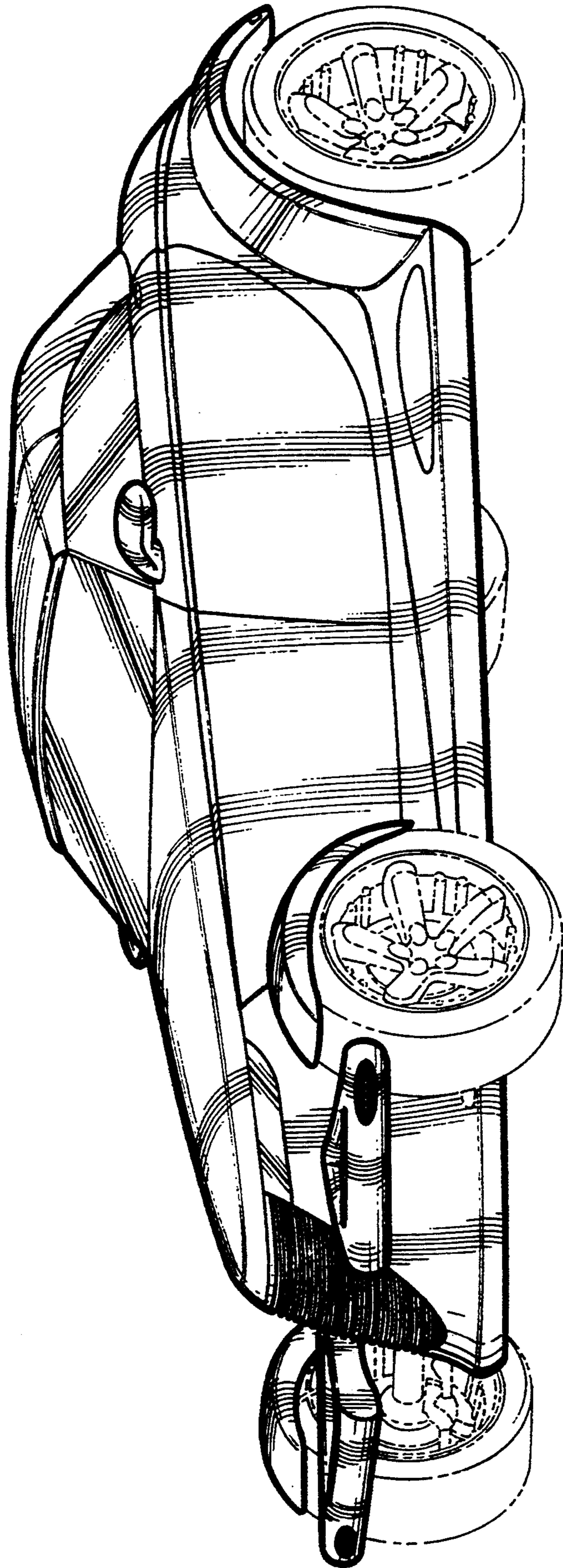

Fig-1



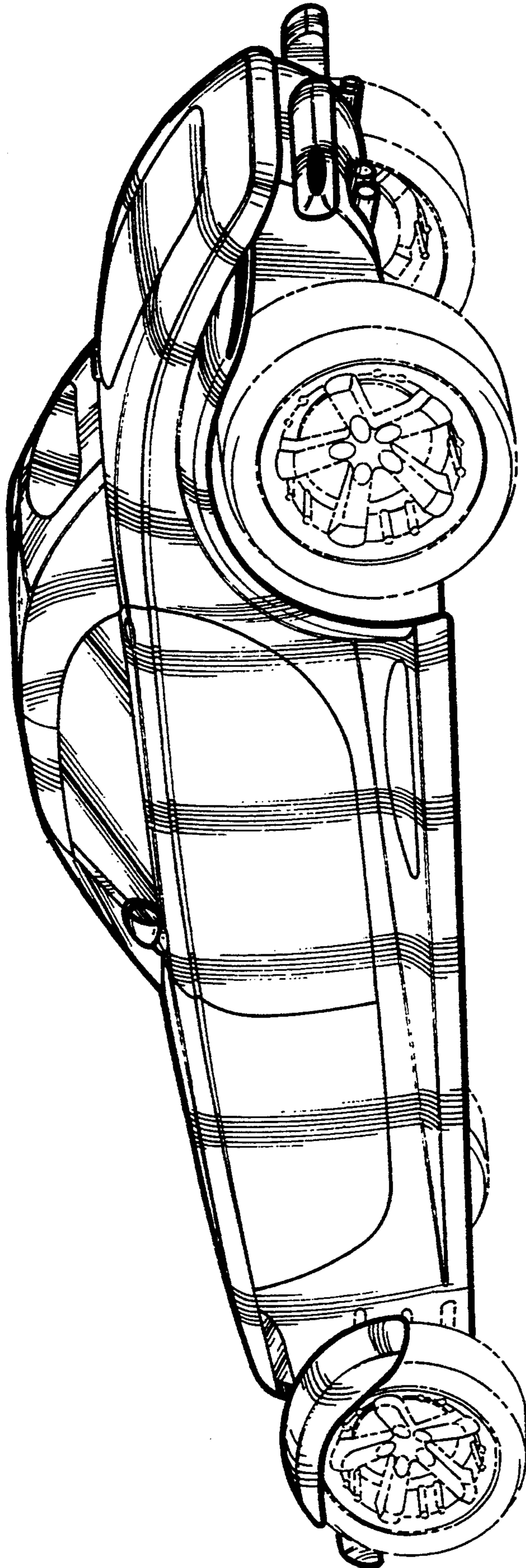

Fig-2

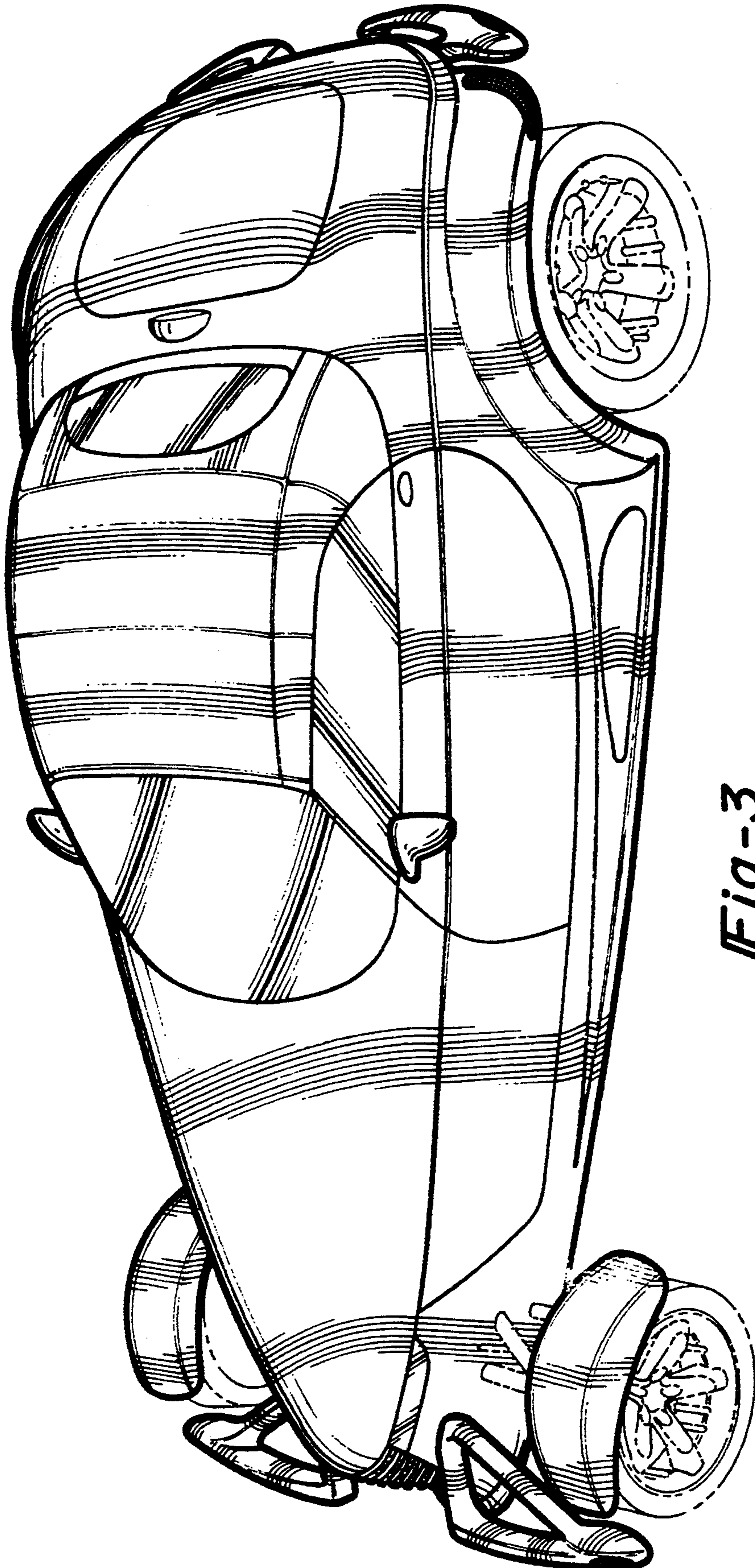

Fig-3

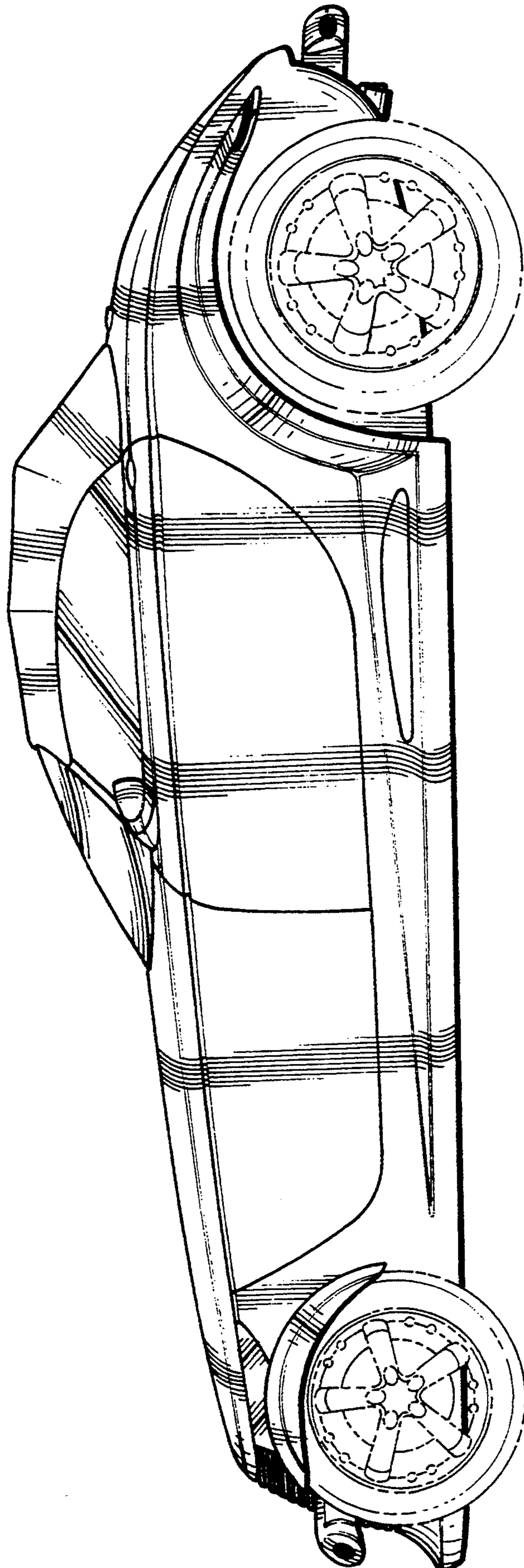

Fig - 4



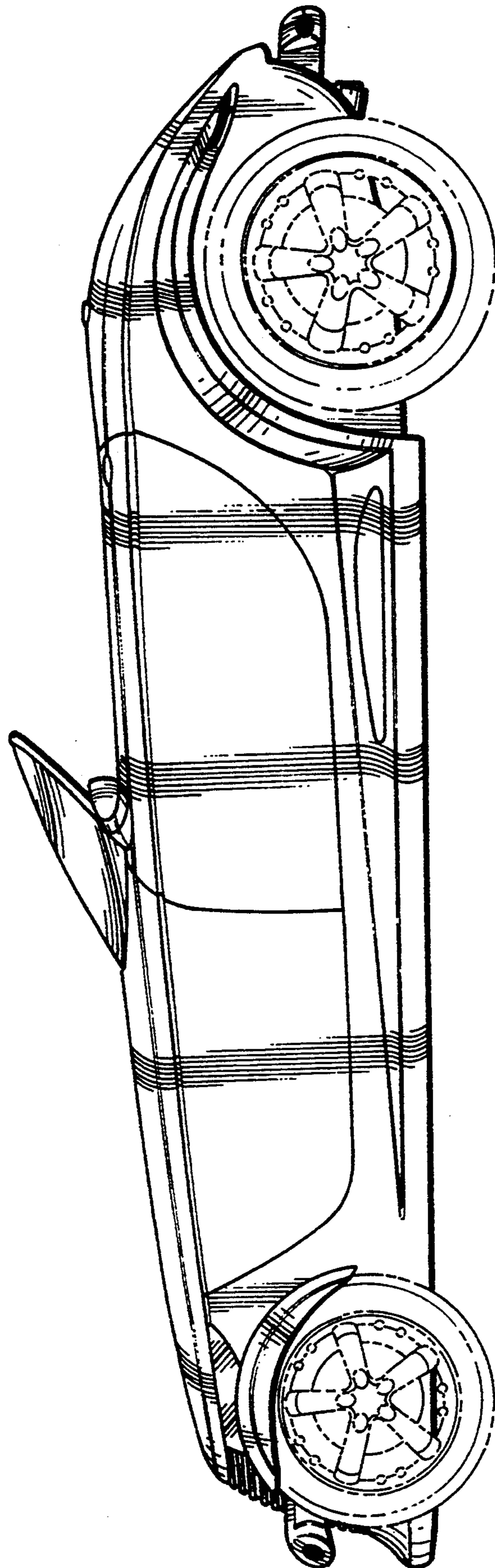

Fig-5

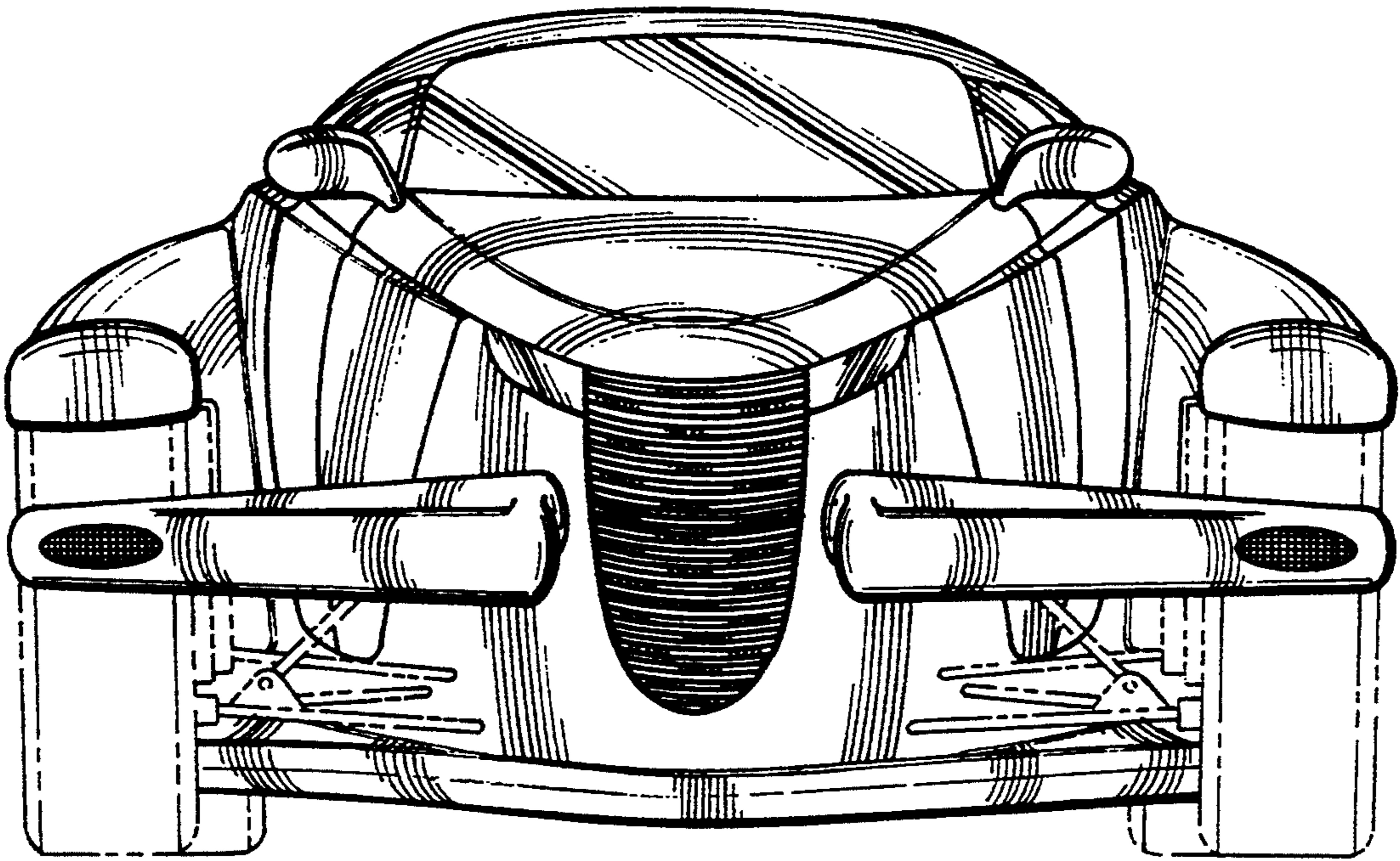

Fig-6

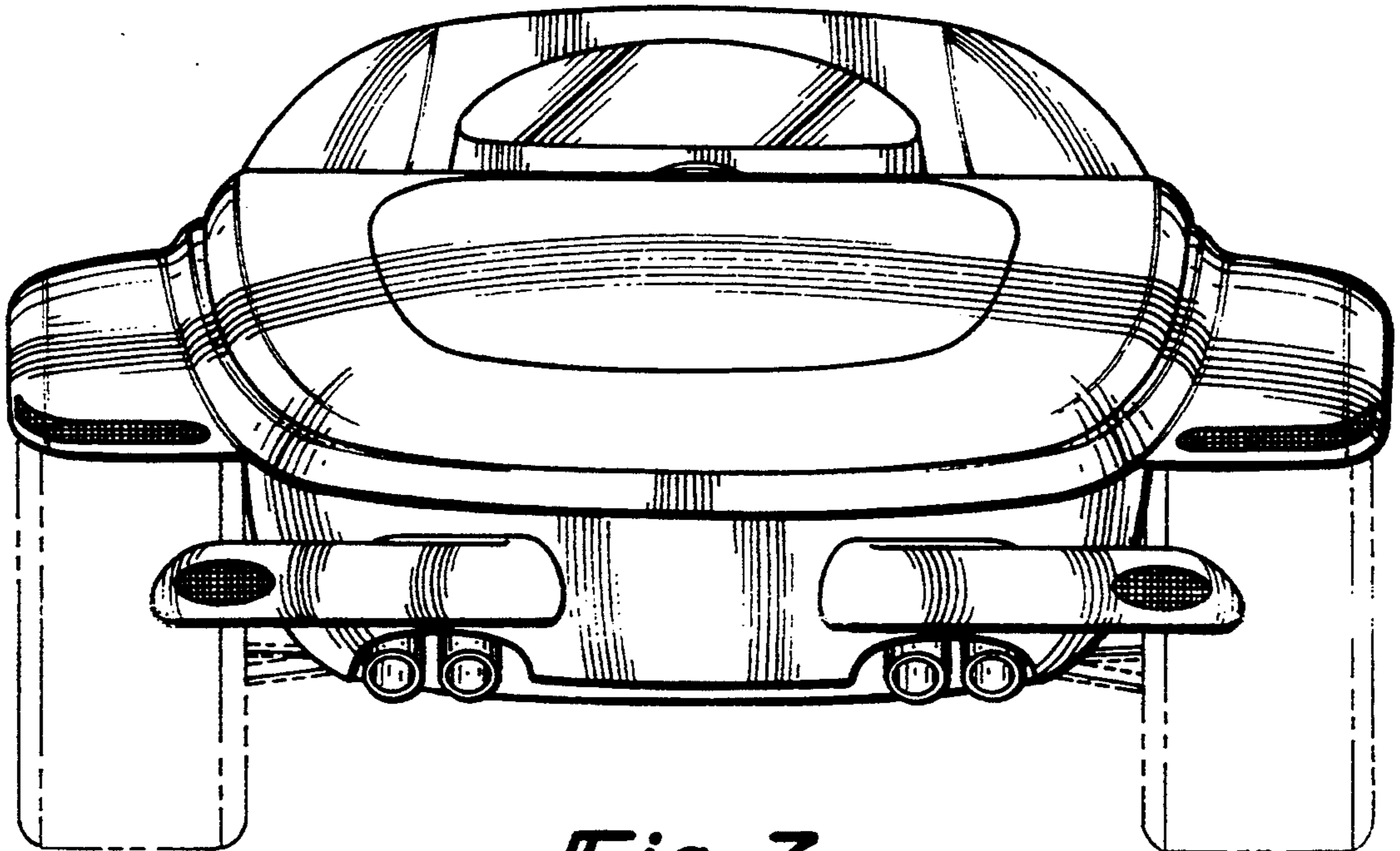

Fig-7