



US00D355291S

United States Patent [19]

Soederberg

[11] Patent Number: **Des. 355,291**

[45] Date of Patent: **** Feb. 7, 1995**

[54] **FORKLIFT**

[75] Inventor: **Richard Soederberg, Mühlacker, Germany**

[73] Assignee: **Dr. Ing h.c.f. Porsche AG, Weissach, Germany**

[**] Term: **14 Years**

[21] Appl. No.: **12,205**

[22] Filed: **Aug. 26, 1993**

[30] **Foreign Application Priority Data**

Feb. 26, 1993 [DE] Germany M9301573.9

[52] U.S. Cl. **D34/28**

[58] Field of Search D34/28, 34, 37; 414/529, 785, 607; 180/89.12, 89.14, 89.17

[56] **References Cited**

U.S. PATENT DOCUMENTS

- D. 231,340 4/1974 Haynes D34/34
- D. 234,050 1/1975 Crawford et al. D34/34
- D. 338,764 8/1993 Furuta D34/34

- 3,754,673 8/1973 Barda et al. 414/785
- 3,893,579 7/1975 Glewwe 414/607
- 4,043,472 8/1977 Hoyt 414/785
- 4,688,981 8/1987 Raunsborge et al. 414/607

Primary Examiner—Wallace R. Burke
Assistant Examiner—Robin V. Taylor
Attorney, Agent, or Firm—Evenson, McKeown, Edwards and Lenahan

[57] **CLAIM**

The ornamental design for a forklift, as shown and described.

DESCRIPTION

FIG. 1 is a right side view of a forklift showing my new design;
FIG. 2 is a left side view thereof;
FIG. 3 is a rear end view thereof;
FIG. 4 is a front view thereof;
FIG. 5 is a left, front perspective view thereof; and,
FIG. 6 is a top, left perspective view thereof.
The broken line showing is for illustrative purposes only and forms no part of the claimed design.

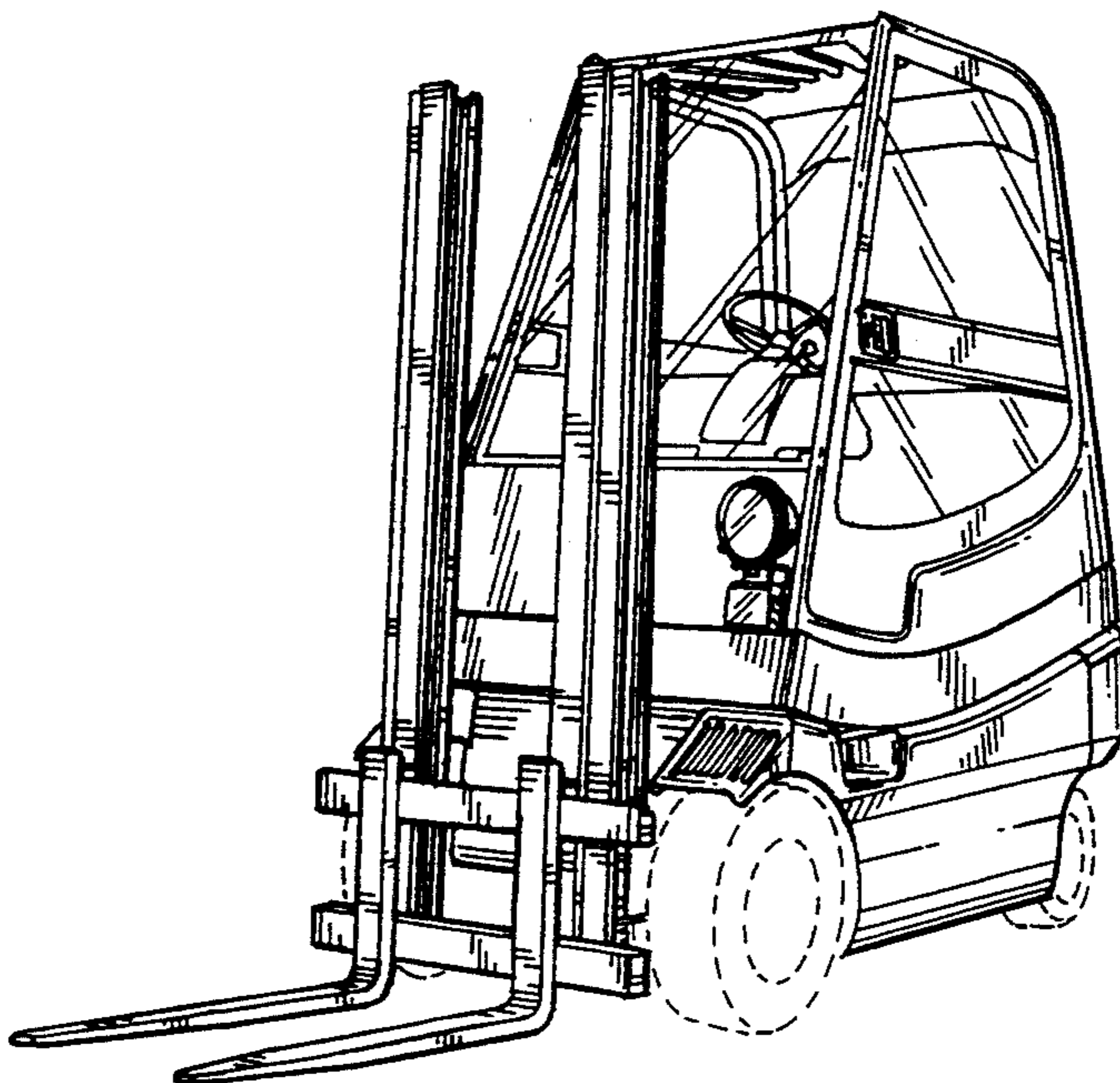
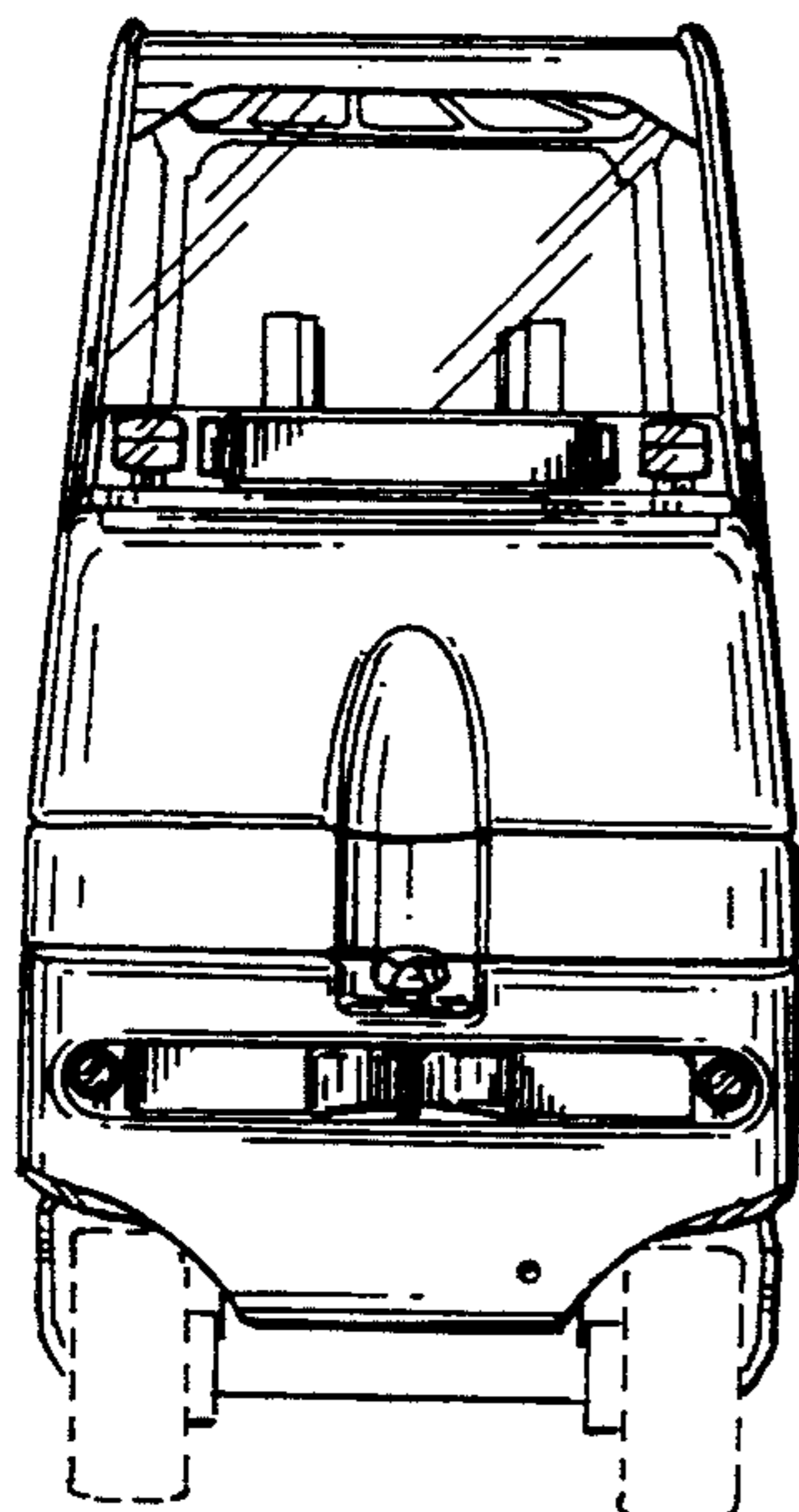

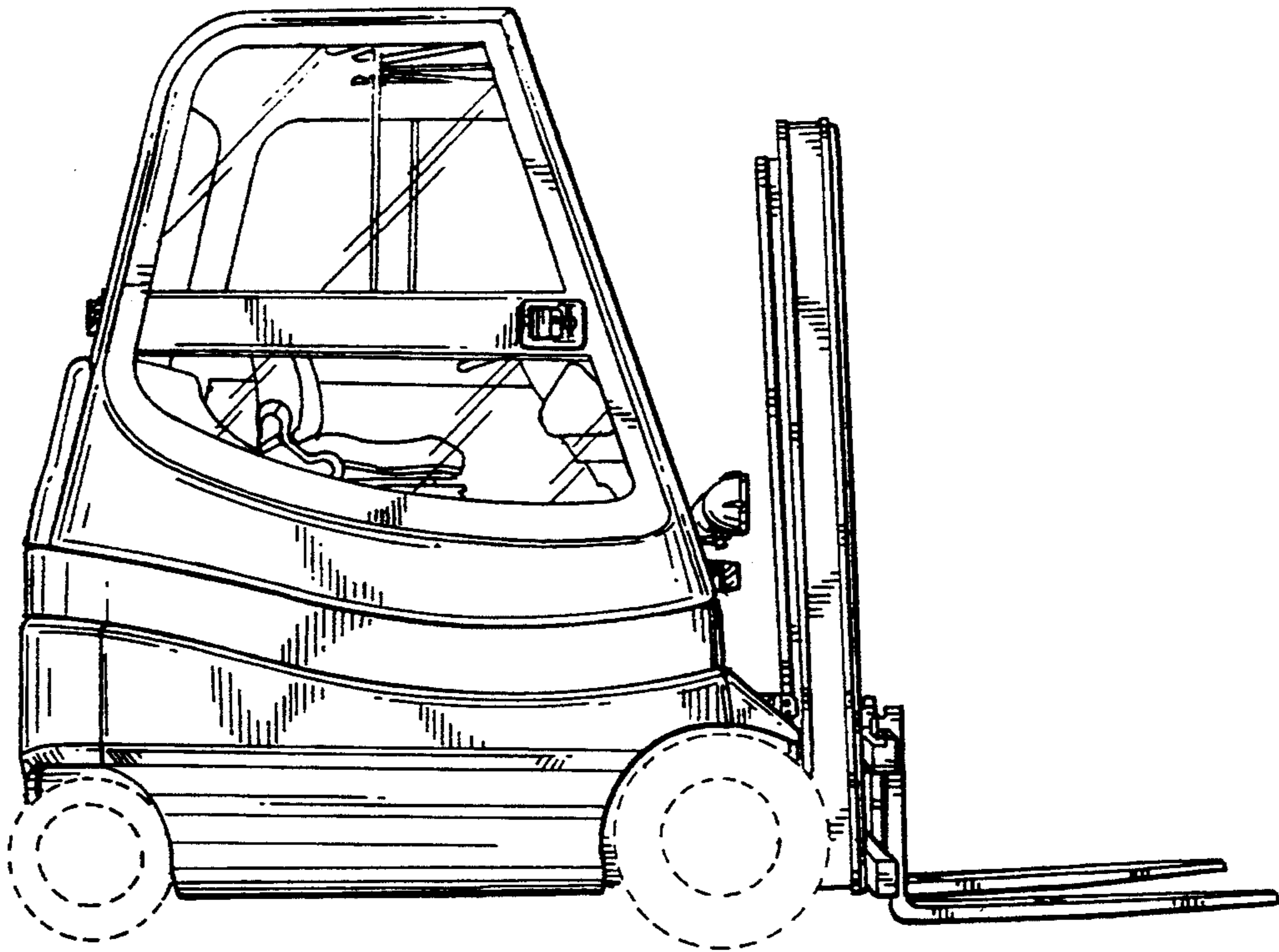

FIG. 1

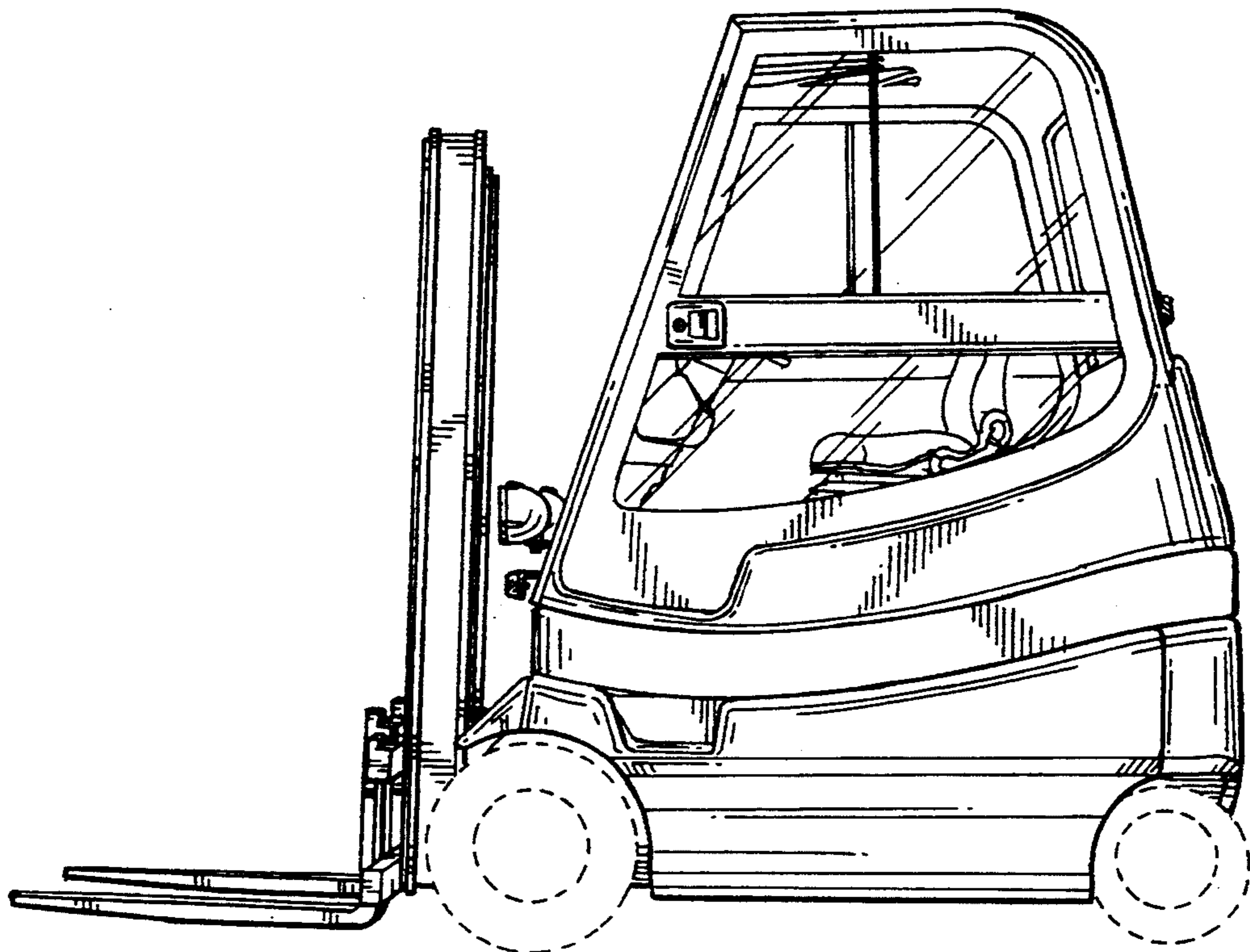

FIG. 2

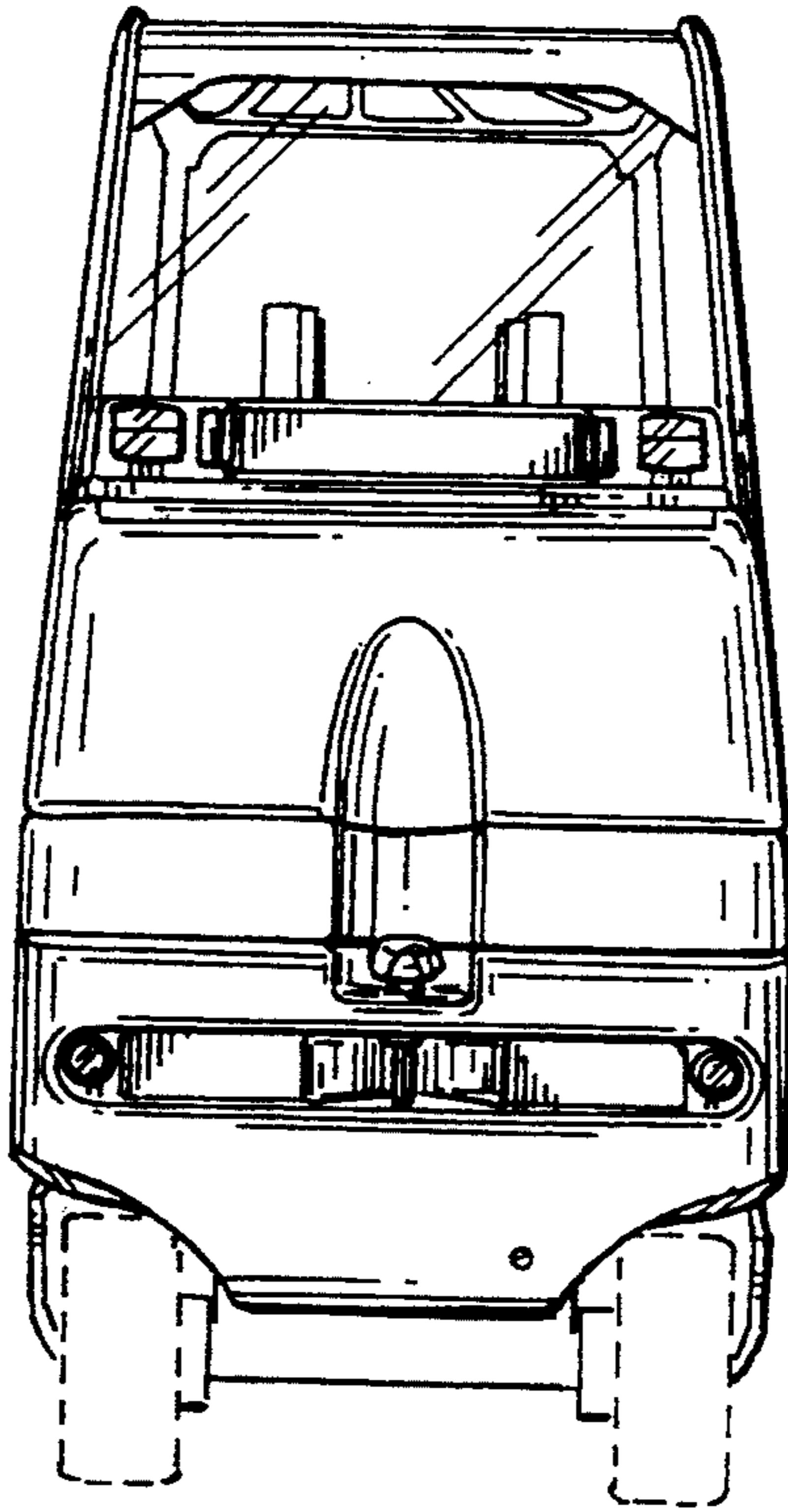

FIG. 3

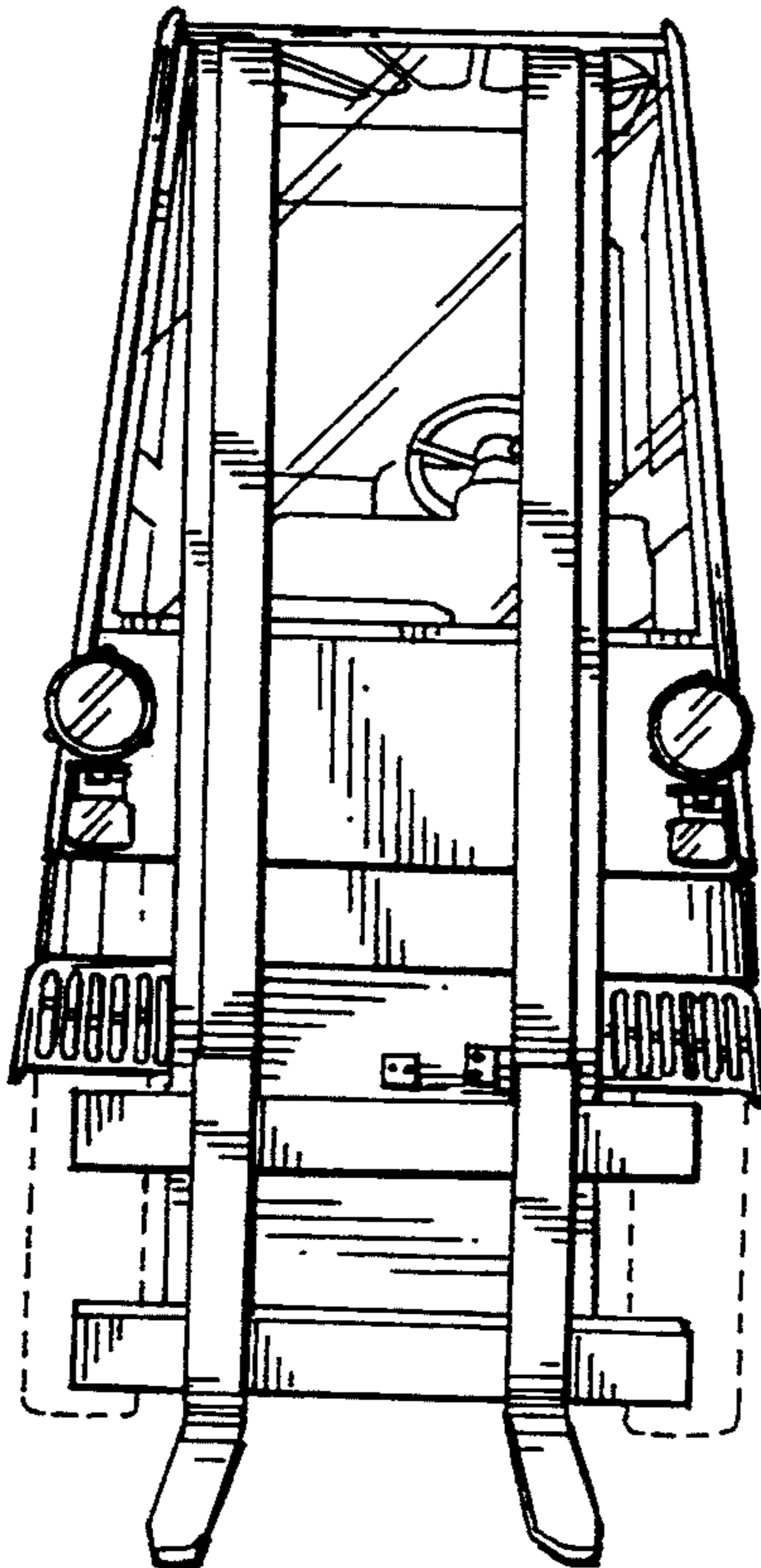

FIG. 4

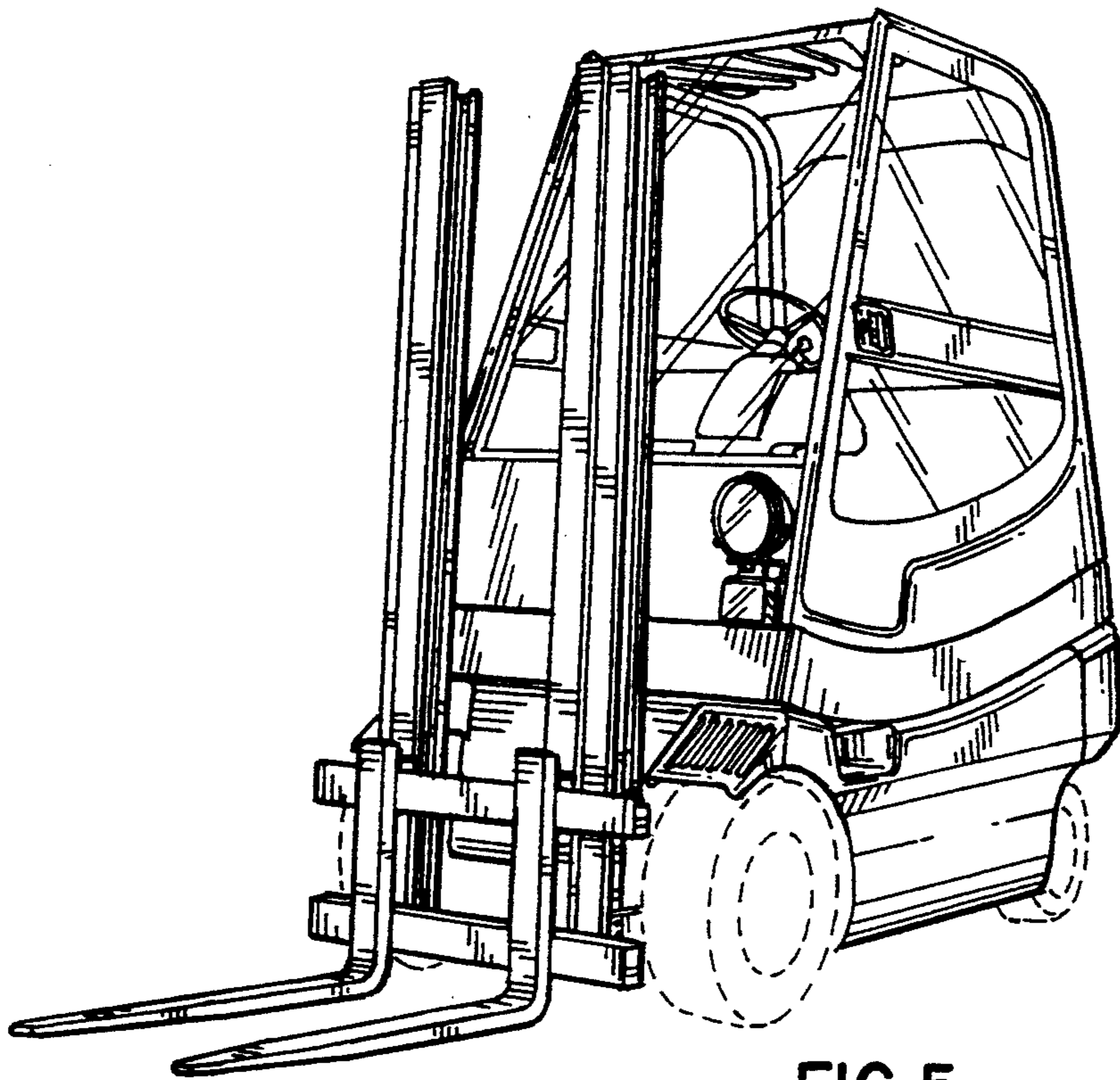

FIG. 5

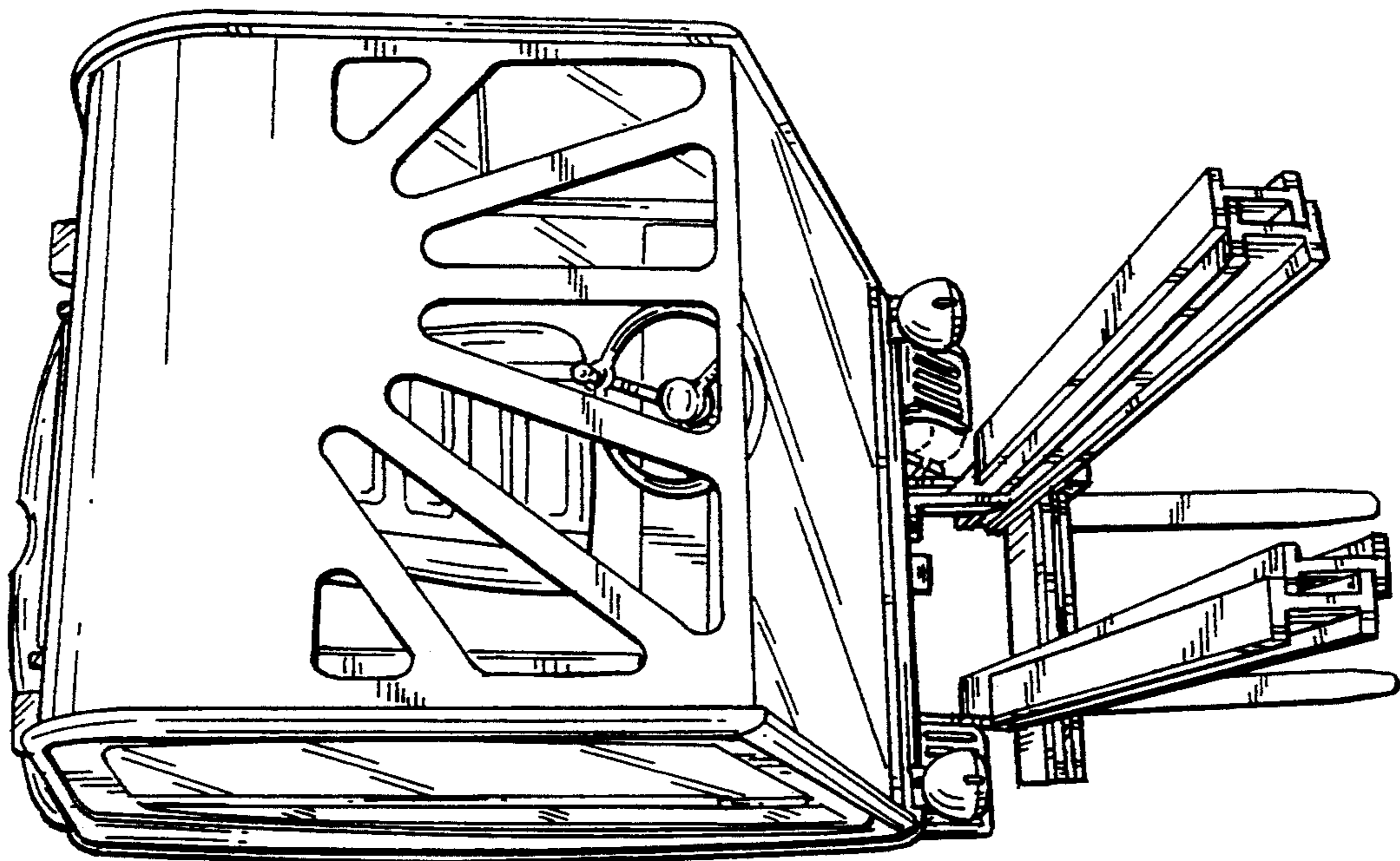

FIG. 6