



US00D355113S

United States Patent [19]

Shimajiri

[11] Patent Number: Des. 355,113

[45] Date of Patent: ** Feb. 7, 1995

[54] BOARD CLAMP

[75] Inventor: Naohiro Shimajiri, Toyota, Japan

[73] Assignee: Nifco Inc., Kanagawa, Japan

[**] Term: 14 Years

[21] Appl. No.: 2,554

[22] Filed: Dec. 15, 1992

[52] U.S. Cl. D8/382

[58] Field of Search D8/382; 24/453;
411/500, 508, 509, 907

[56] **References Cited**

U.S. PATENT DOCUMENTS

3,249,973	5/1966	Seckerson	411/509
3,412,437	11/1968	Bennett	411/509
3,550,217	12/1970	Collyer	411/509
3,678,797	7/1972	Seckerson	411/509
3,745,612	7/1973	Seckerson	411/509
4,715,095	12/1987	Takahashi	24/453

4,987,656 1/1991 Sato 24/453

Primary Examiner—B. J. Bullock

Attorney, Agent, or Firm—Wenderoth, Lind & Ponack

[57] **CLAIM**

The ornamental design for a board clamp, as shown and described.

DESCRIPTION

FIG. 1 is a front elevational view of a board clamp showing my new design;
 FIG. 2 is a right side elevational view thereof;
 FIG. 3 is a top plan view thereof;
 FIG. 4 is a bottom plan view thereof;
 FIG. 5 is a cross-sectional view taken in the direction of the arrows on line 5—5 in FIG. 1;
 FIG. 6 is a cross-sectional view taken in the direction of the arrows on line 6—6 in FIG. 1; and,
 FIG. 7 is a front elevational view thereof in its position of use, the broken line showing of the boards being for illustrative purposes only.

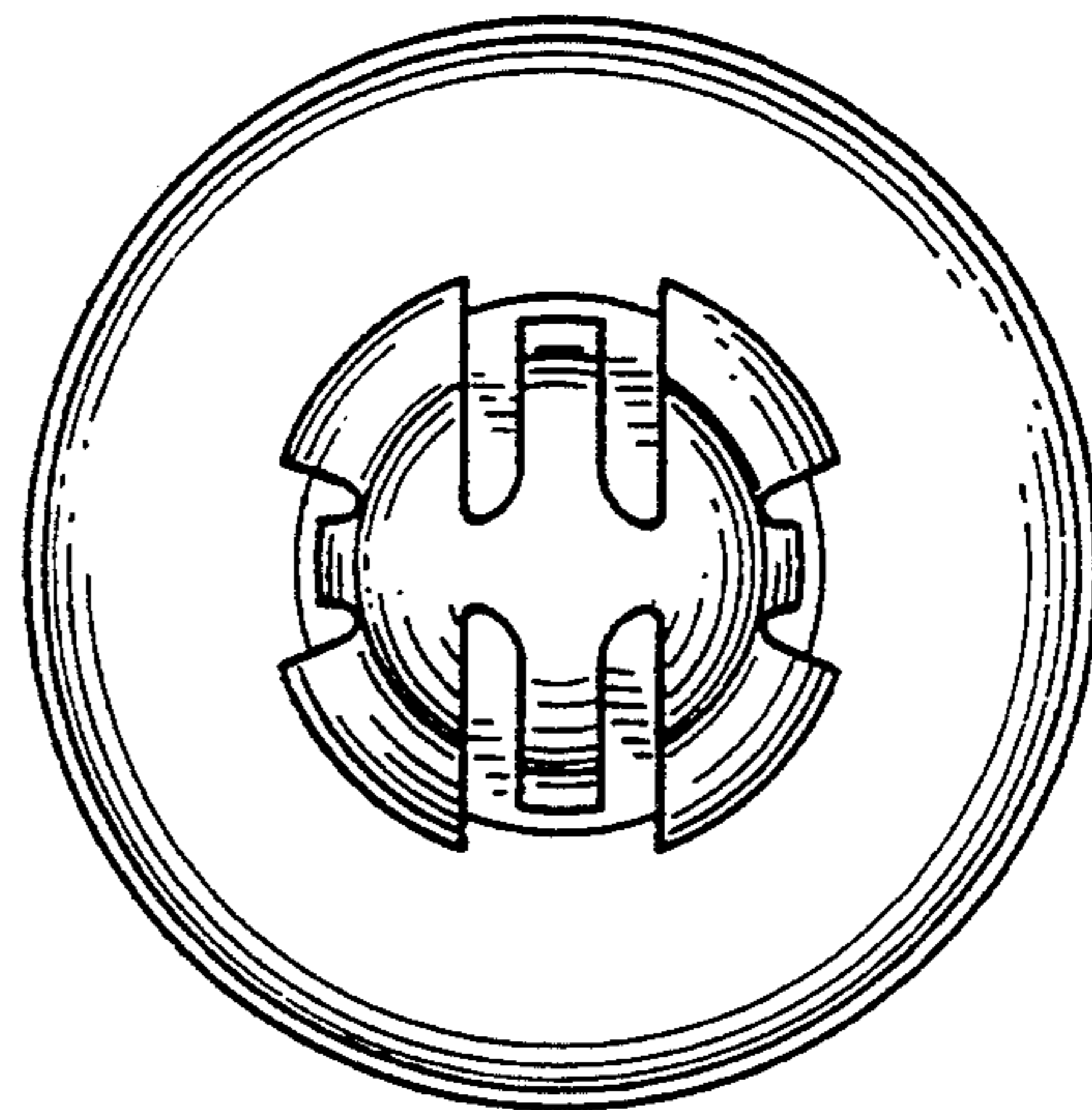
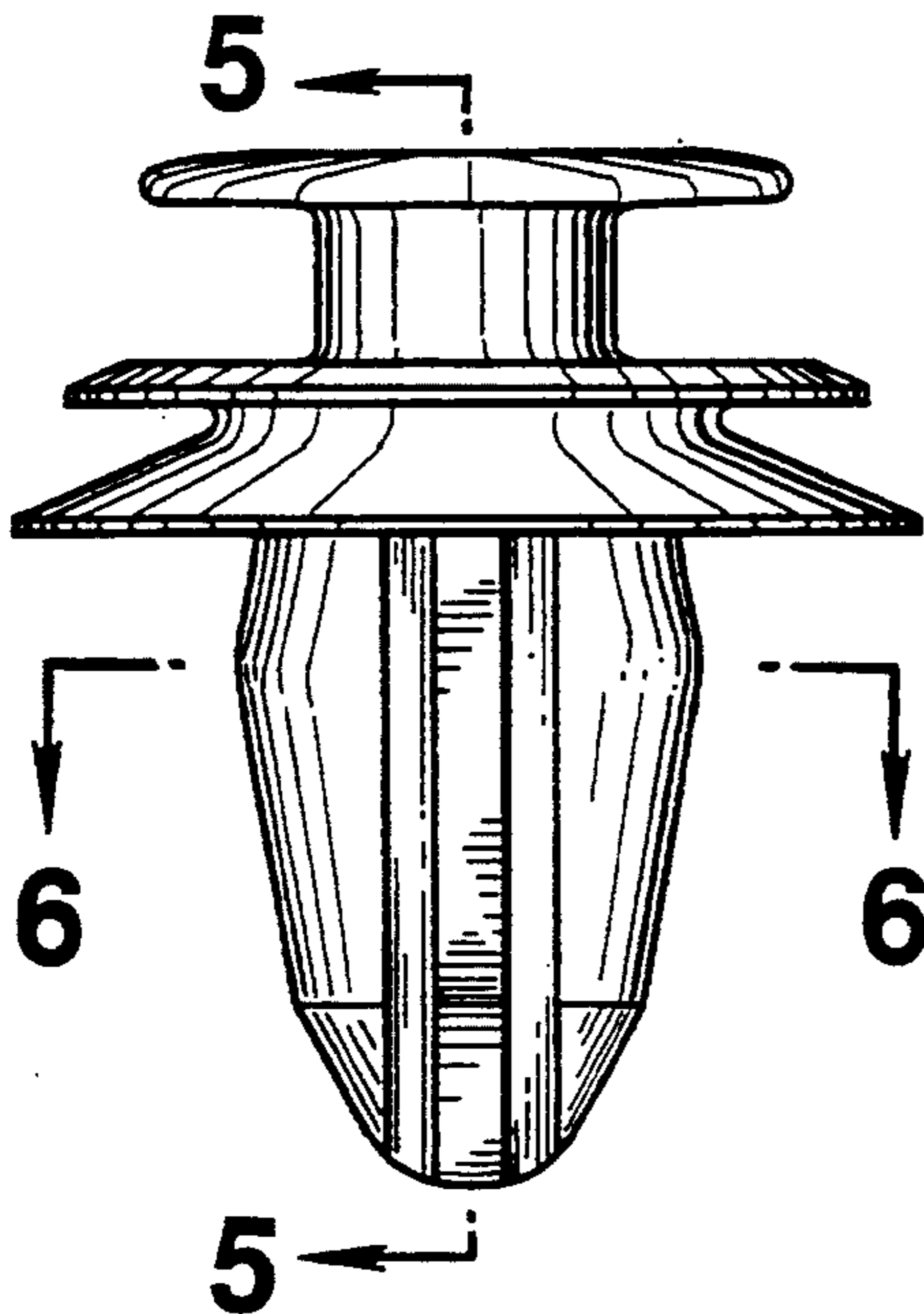

FIG.1

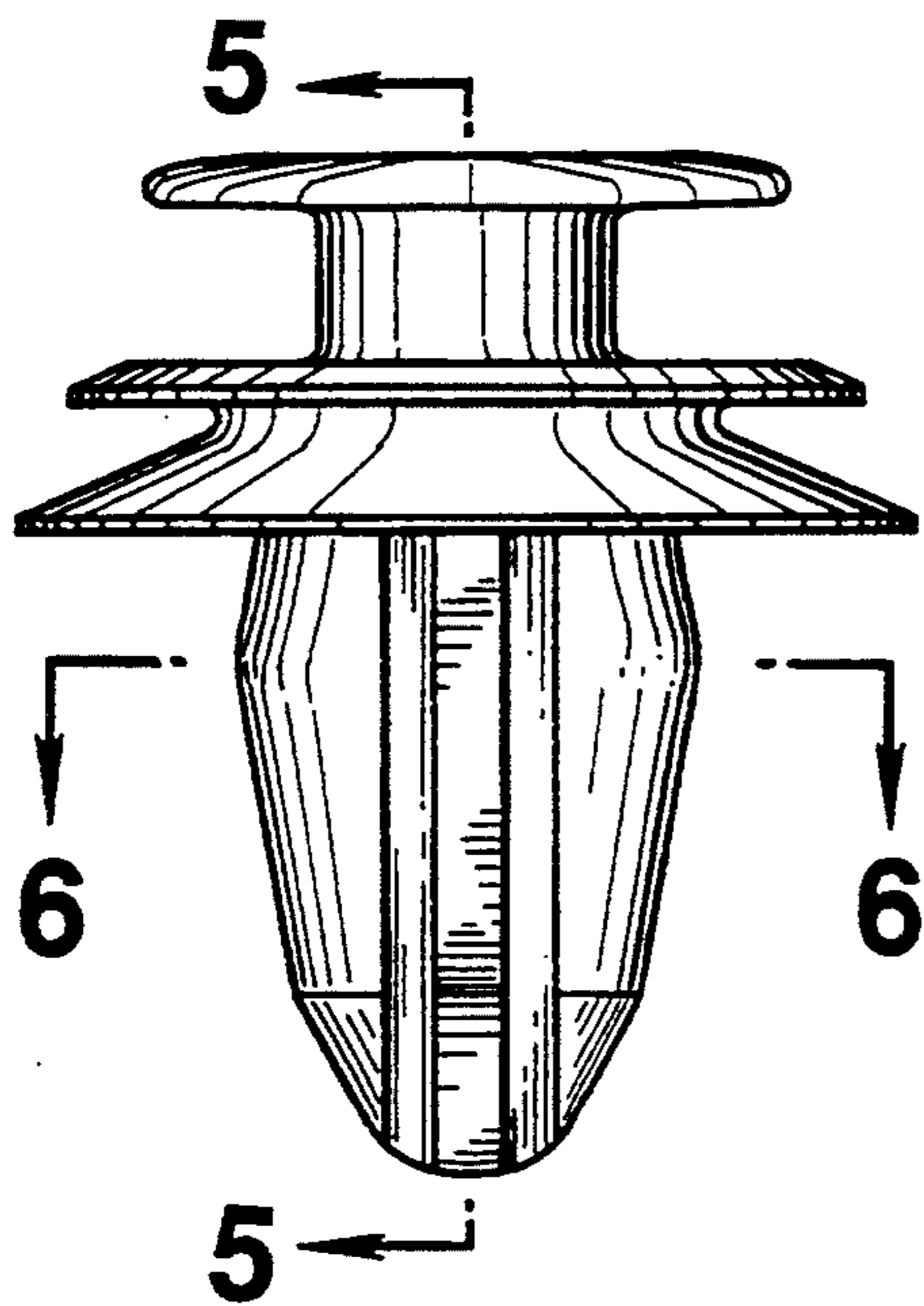

FIG.2

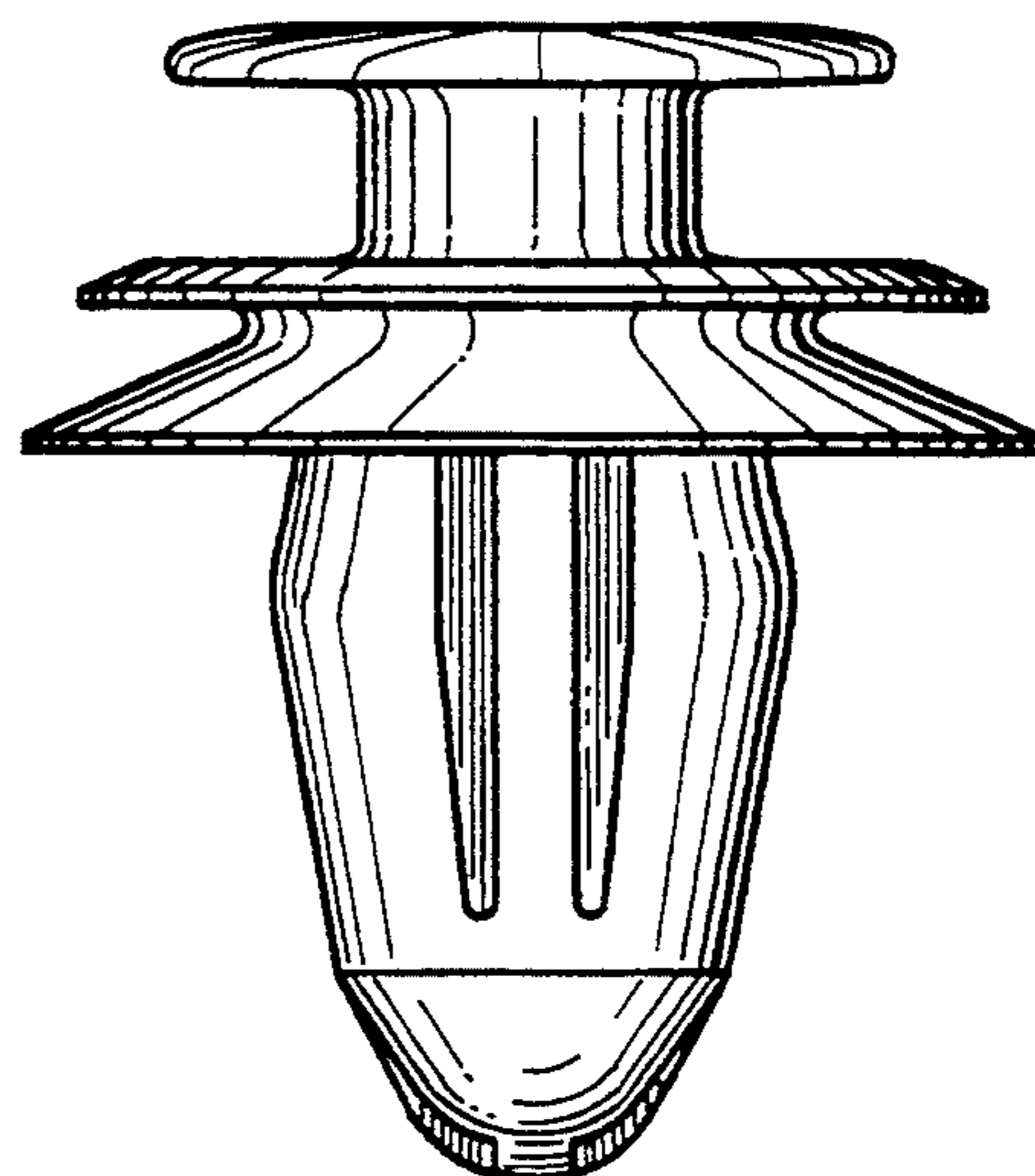

FIG.3

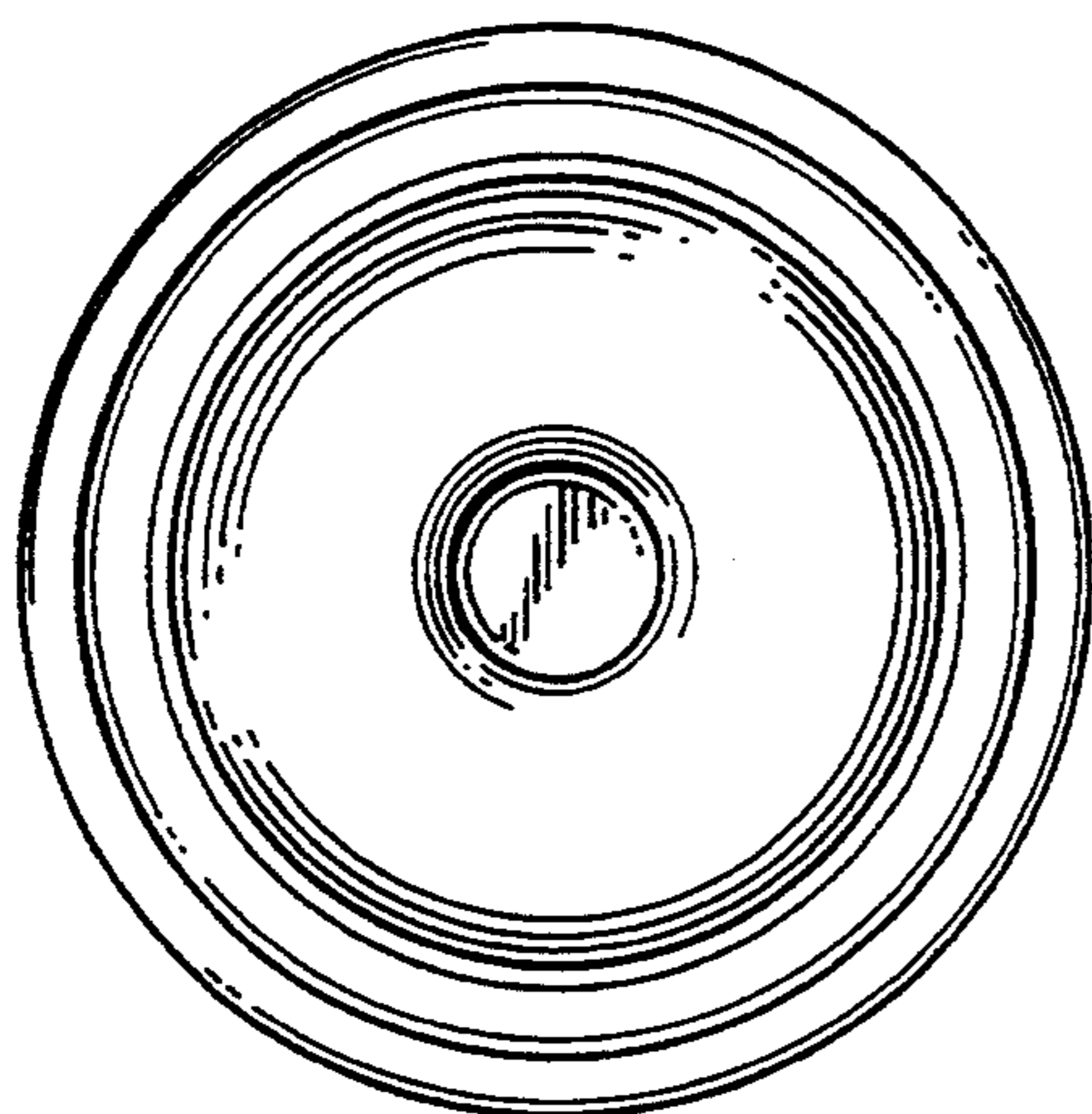

FIG.4

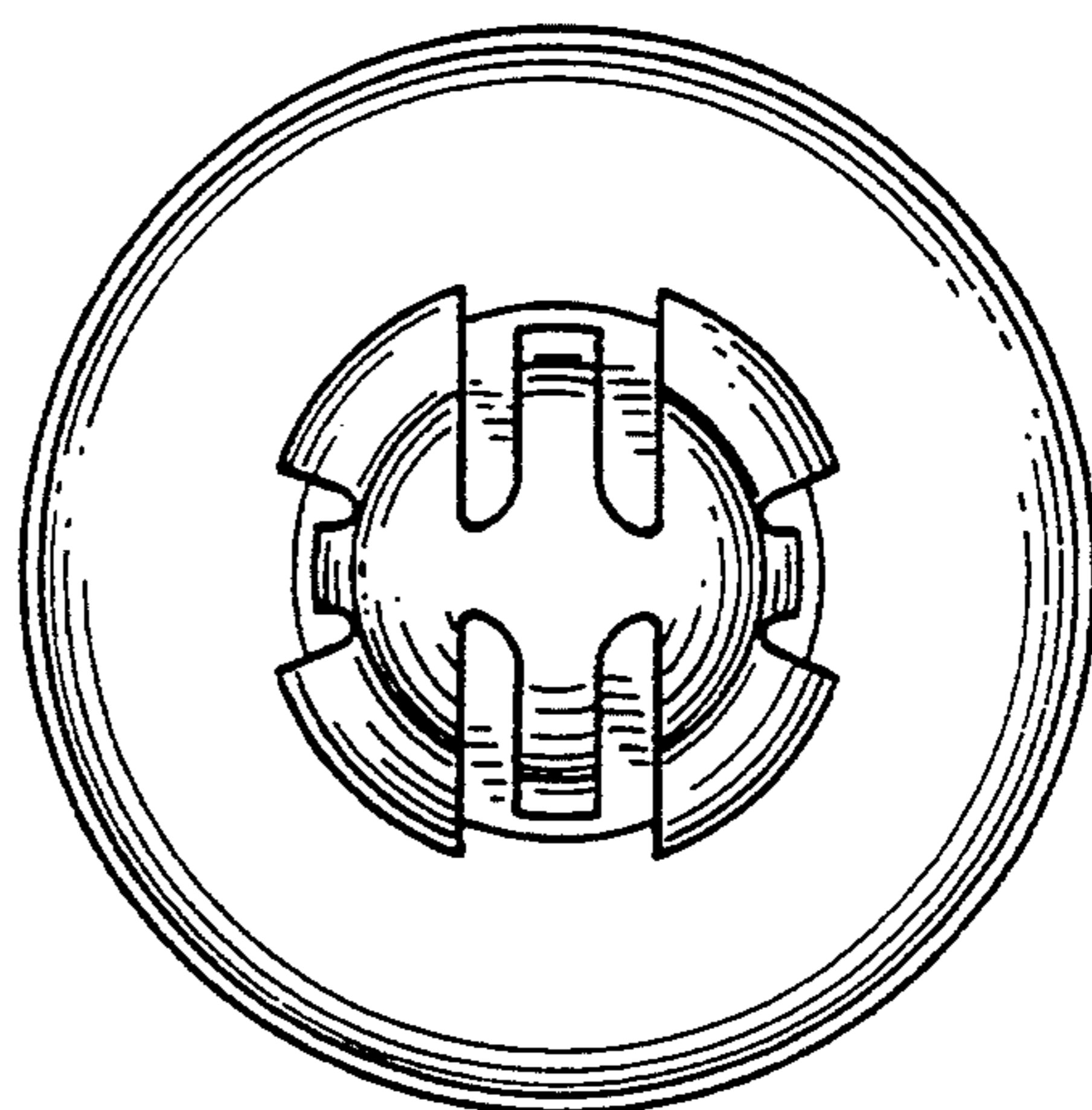

FIG.5

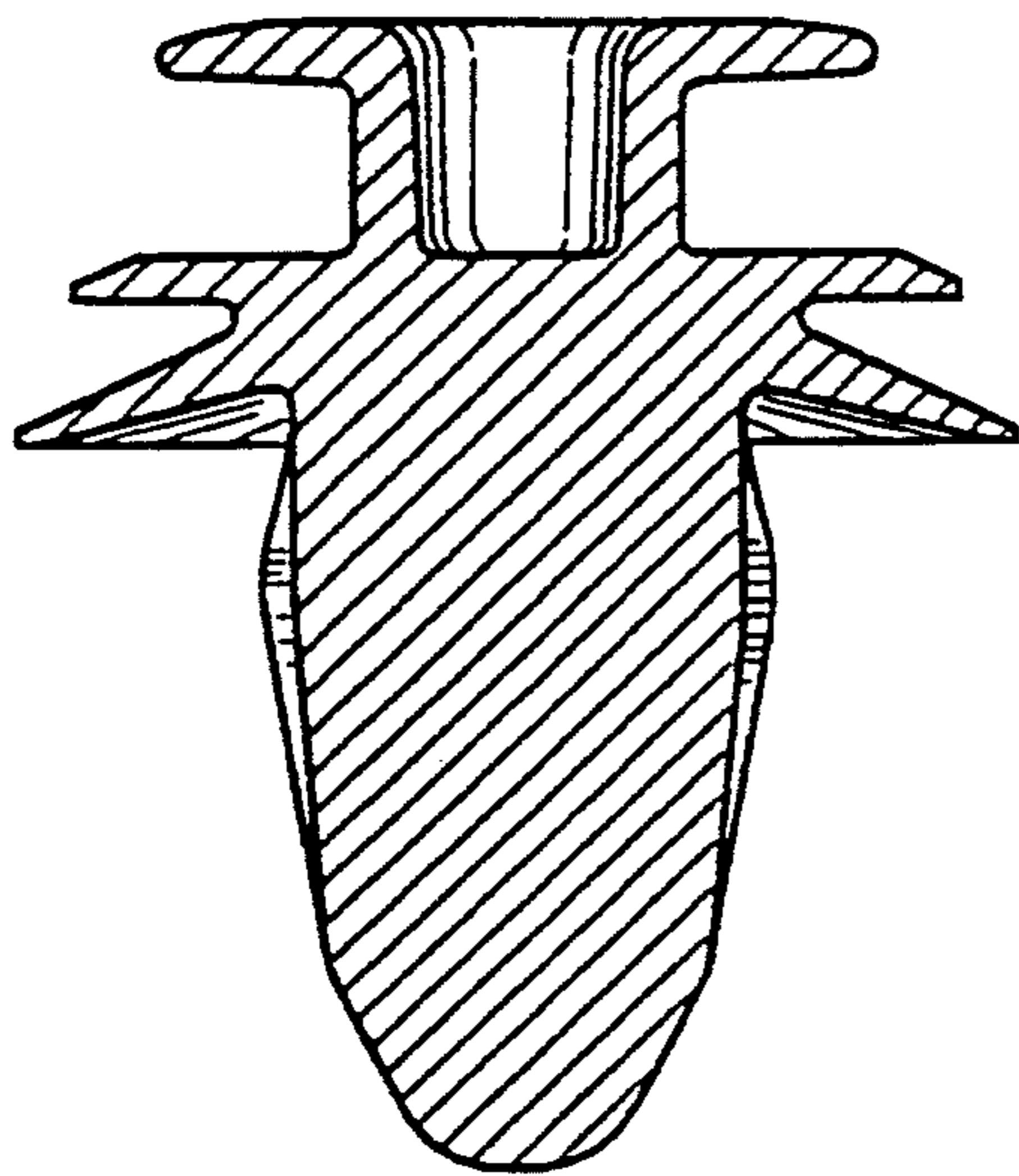

FIG.6

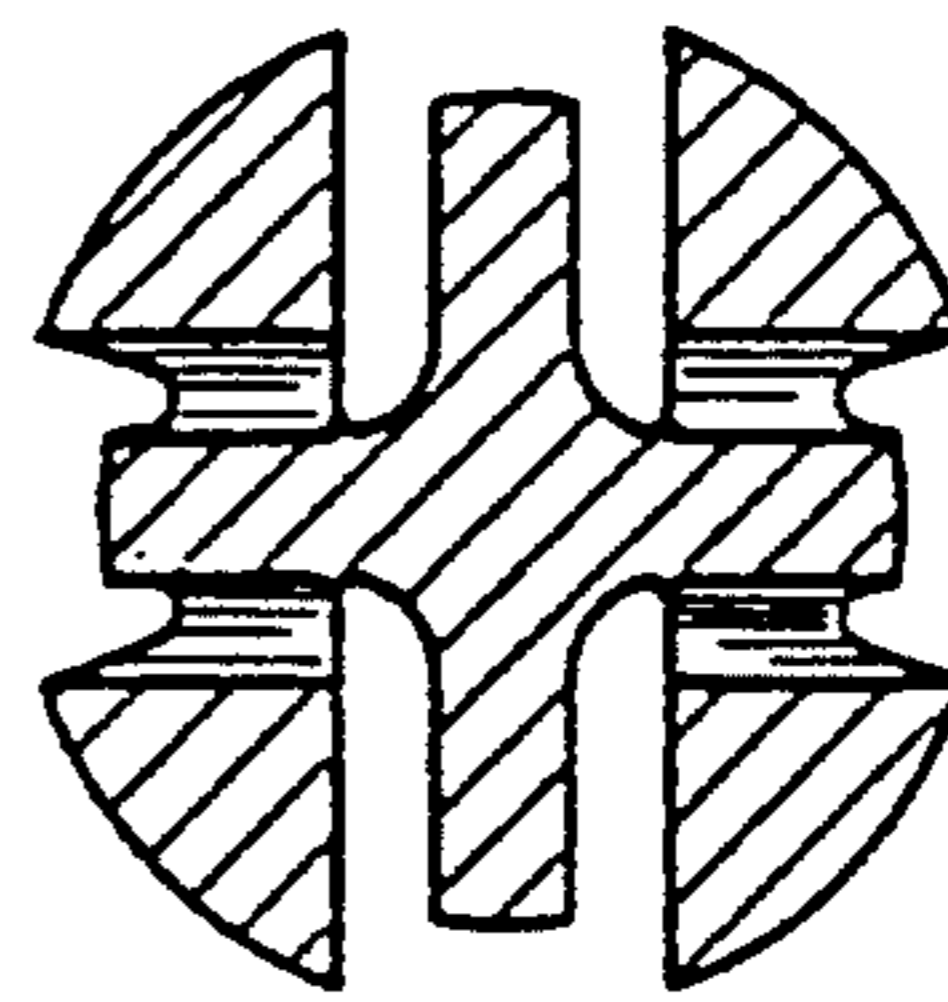

FIG.7

