



US00D354986S

United States Patent [19]

[11] Patent Number: **Des. 354,986**

Chu

[45] Date of Patent: **** Jan. 31, 1995**

[54] **PAPER FASTENER**

[75] Inventor: **Cornel Chu**, London, England

[73] Assignee: **Hi-Tech Industries Limited**, London, England

[**] Term: **14 Years**

[21] Appl. No.: **6,791**

[22] Filed: **Apr. 7, 1993**

[30] **Foreign Application Priority Data**

Oct. 8, 1992 [GB] United Kingdom 2026308

[52] U.S. Cl. **D19/65; D8/395; D19/86**

[58] **Field of Search** **D19/65, 75, 86, 88, D19/99, 100; D8/395; 24/67 R, 67.1-67.11, 67 CF; 402/15; 281/42, 45**

[56] **References Cited**

U.S. PATENT DOCUMENTS

D. 206,786	1/1967	McCormick	D19/65 X
D. 225,906	1/1973	Cline	D19/65
273,301	3/1883	Page et al.	24/67.9
915,073	3/1909	Chapin	24/67 R
2,543,144	2/1951	Wold	402/15
4,255,837	3/1981	Holtz	24/67 R

FOREIGN PATENT DOCUMENTS

1246673 8/1967 Germany 24/67.9

Primary Examiner—Martie Thompson
Attorney, Agent, or Firm—Armstrong, Westerman, Hattori, McLeland & Naughton

[57] **CLAIM**

The ornamental design for a paper fastener, as shown and described.

DESCRIPTION

FIG. 1 shows a perspective view of a paper fastener according to the present design, the view being taken from above, one side and one end;

FIG. 2 shows an bottom plan view of the paper fastener of FIG. 1;

FIG. 3 shows a side view of the paper fastener of FIG. 1 taken from the other side to the view of FIG. 1;

FIG. 4 shows an end view of the paper fastener of FIG. 1 taken from the other end to the view of FIG. 1; and,

FIG. 5 shows a cross-sectional view on the line A—A of FIG. 1;

FIG. 6 shows an end elevational view of the paper fastener of FIG. 1 taken from the end shown in FIG. 1; and,

FIG. 7 is a side elevational view of the paper fastener of FIG. 1; taken from the side shown in FIG. 1.

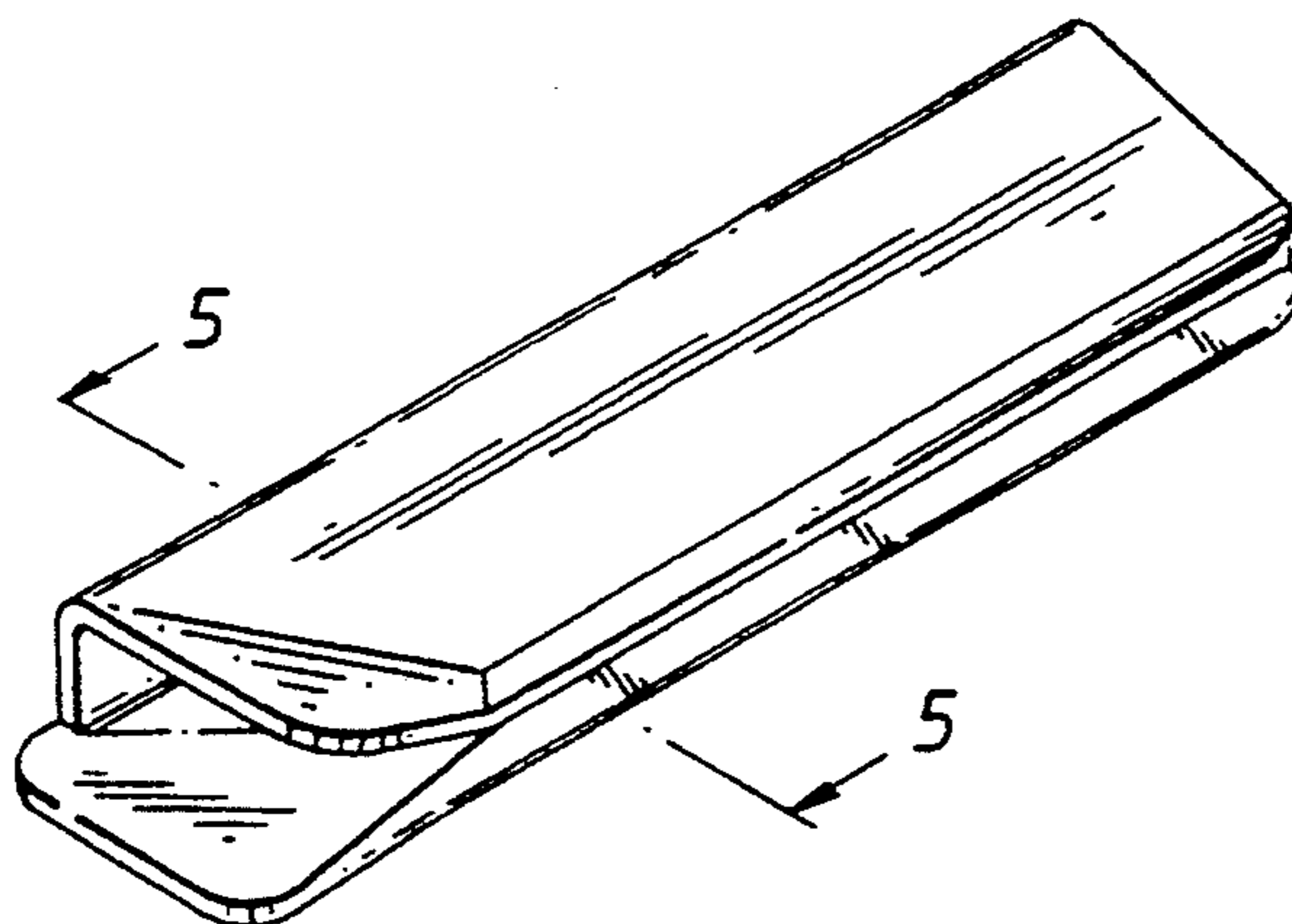

Fig. 1.

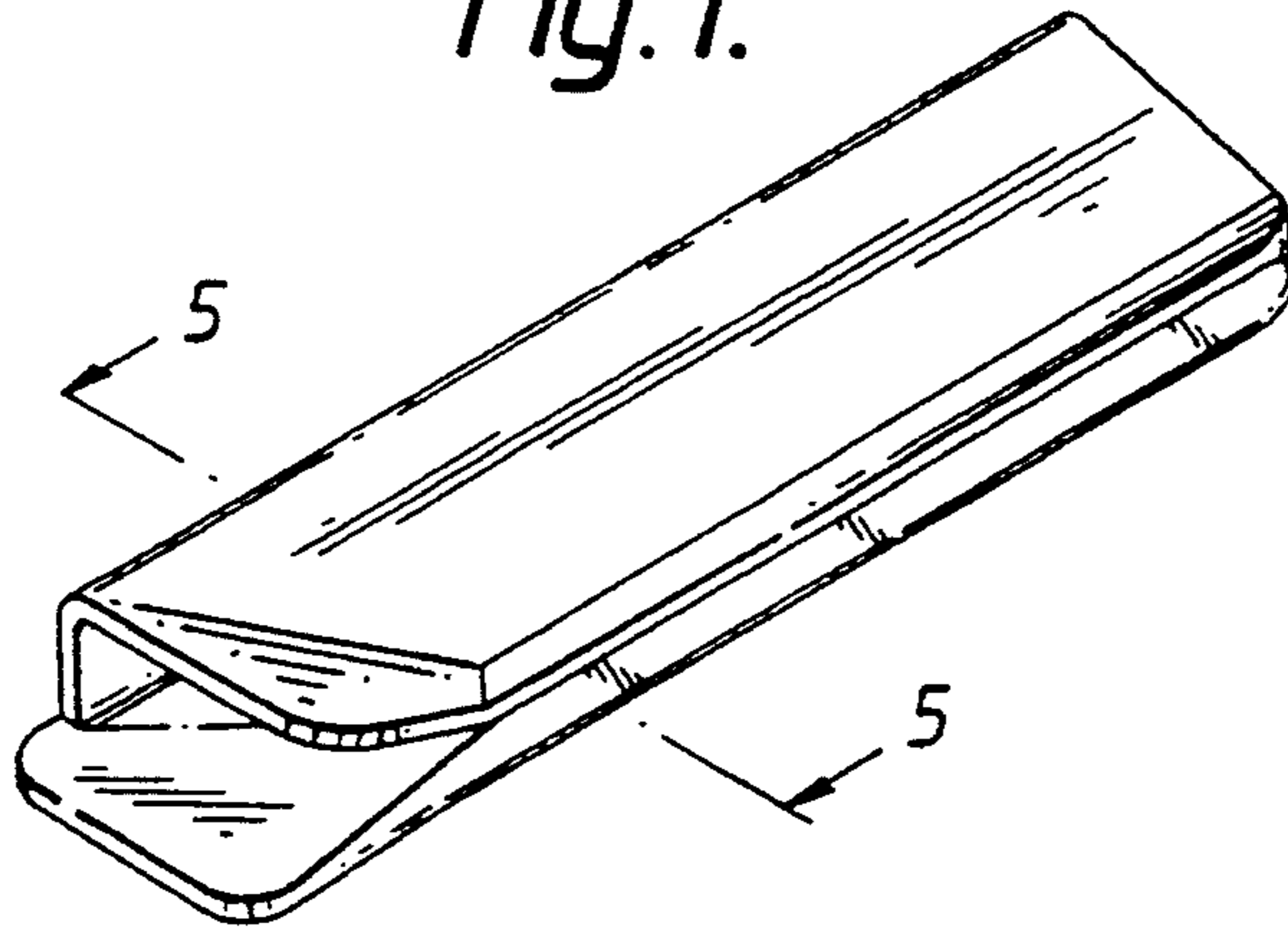

Fig. 2.

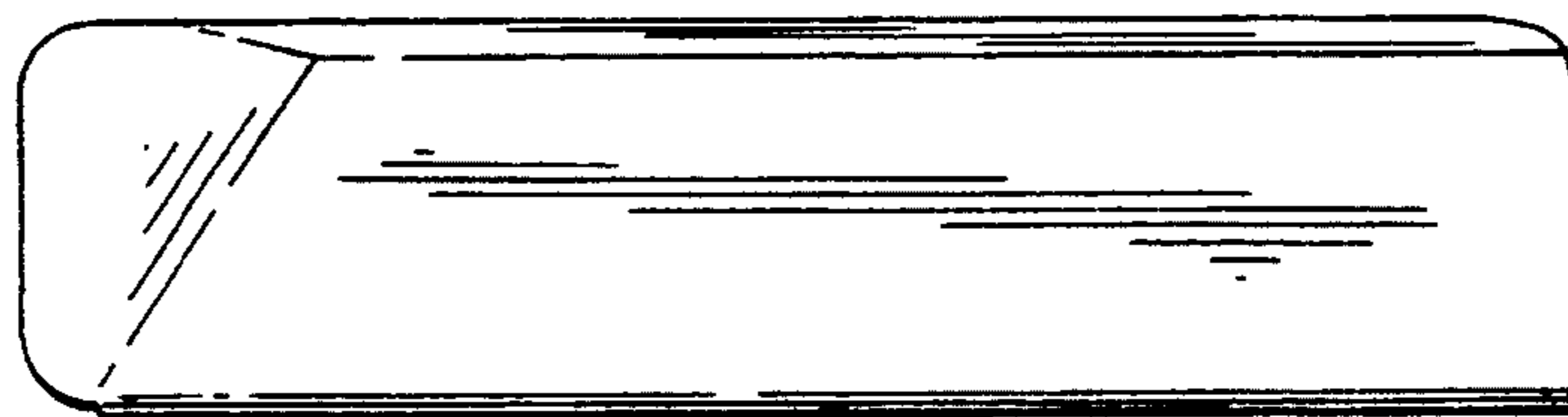

Fig. 3.

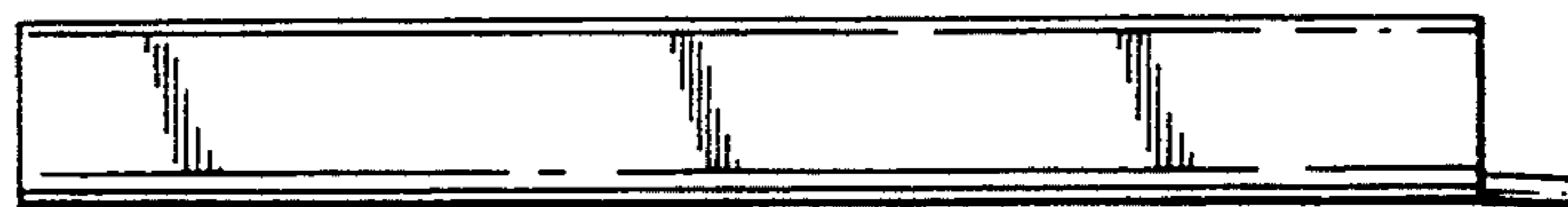

Fig. 4.



Fig. 5.





Fig. 6

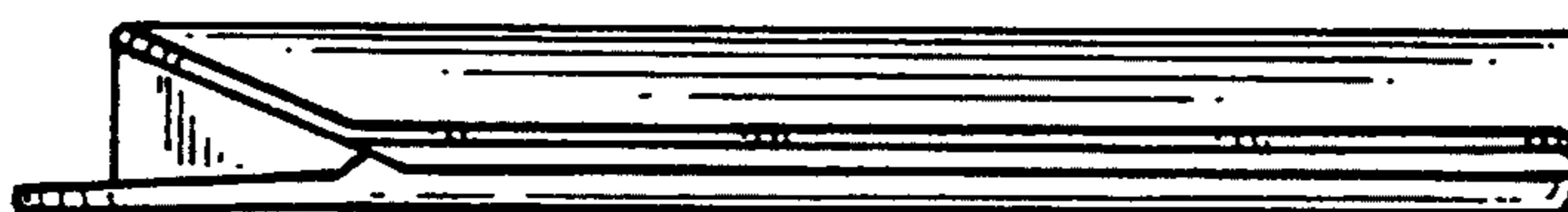

Fig. 7