



US00D354936S

United States Patent [19]

[11] Patent Number: **Des. 354,936**

Kraft et al.

[45] Date of Patent: **** Jan. 31, 1995**

- [54] PASSENGER AIRCRAFT
- [75] Inventors: **Roger E. Kraft**, Ft. Scott; **Jeffrey D. Ackland**, Shawnee; **Harold E. Kraft**, Ft. Scott, all of Kans.; **Martin Hollmann**, Monterrey, Calif.
- [73] Assignee: **Starkraft, Inc.**, Ft. Scott, Kans.
- [**] Term: **14 Years**
- [21] Appl. No.: **12,346**
- [22] Filed: **Oct. 12, 1993**
- [52] U.S. Cl. **D12/344; D12/339**
- [58] Field of Search **D12/319, 326, 337, 339, D12/344; 244/45 R, 55, 91, 45 A, 29**

- 507714 6/1939 United Kingdom .
- 516013 12/1939 United Kingdom .
- 1045209 10/1966 United Kingdom .

OTHER PUBLICATIONS

- Flying, Mar. 1991, article by Peter Garrison, pp. 66-74.
- AOPA Pilot, Aug. 1991, article by Marc E. Cook, pp. 86-92.
- Private Pilot, Apr. 1992, article by Dennis Shattuck, pp. 36-41.
- Private Pilot, Aug. 1992, article by Budd Davisson, pp. 20-29.
- AOPA Pilot, Aug. 1992, article by Marc E. Cook, pp. 42-49.
- AOPA Pilot, Apr. 1993, article by Thomas B. Haines, pp. 36-42.

Primary Examiner—Kay H. Chin
Attorney, Agent, or Firm—Hovey, Williams, Timmons & Collins

[56] References Cited

U.S. PATENT DOCUMENTS

- D. 121,685 7/1940 Koss .
- D. 134,037 10/1942 Robitaille .
- D. 134,425 11/1942 McDonnell, Jr. .
- D. 135,696 5/1943 Duhamel .
- D. 144,020 3/1946 Altman .
- D. 239,522 4/1976 Wheatley .
- D. 244,843 6/1977 Paulson D12/337
- D. 271,294 11/1983 Hauk D12/344
- D. 280,892 10/1985 Mazzoni .
- 1,203,558 10/1916 Gallaudet .
- 1,551,983 9/1925 Dornier .
- 1,648,818 11/1927 Mannick .
- 1,758,866 5/1930 Sweet .
- 1,842,055 1/1932 Stout .
- 1,854,364 4/1932 Bellanca .
- 1,858,761 5/1932 Bellanca .
- 1,858,762 5/1932 Bellanca .
- 2,140,783 12/1938 Bellanca .
- 2,395,513 2/1946 Stalker .
- 2,691,494 10/1954 Custer .
- 2,738,148 3/1956 Stulen .
- 3,191,888 6/1965 Sklenka .
- 3,807,665 4/1974 Coombe .
- 5,320,306 6/1994 Gennaro 244/45 R

FOREIGN PATENT DOCUMENTS

- 643974 9/1928 France .
- 875648 9/1942 France .
- 342987 9/1936 Italy .

[57] CLAIM

The ornamental design for a passenger aircraft, as shown and described.

DESCRIPTION

FIG. 1 is a top left front perspective view of our ornamental design for a passenger aircraft;
 FIG. 2 is a top plan view thereof;
 FIG. 3 is a left side elevational view thereof with the landing gear extended;
 FIG. 4 is a right side elevational view thereof with the landing gear extended;
 FIG. 5 is a bottom view thereof with the landing gear extended;
 FIG. 6 is a rear elevational view thereof with the landing gear extended;
 FIG. 7 is a front elevational view thereof with the landing gear extended;
 FIG. 8 is a right side elevational view thereof with the landing gear retracted;
 FIG. 9 is a rear elevational view thereof with the landing gear retracted;
 FIG. 10 is a left side elevational view thereof with the landing gear retracted; and,
 FIG. 11 is a front elevational view thereof with the landing gear retracted.

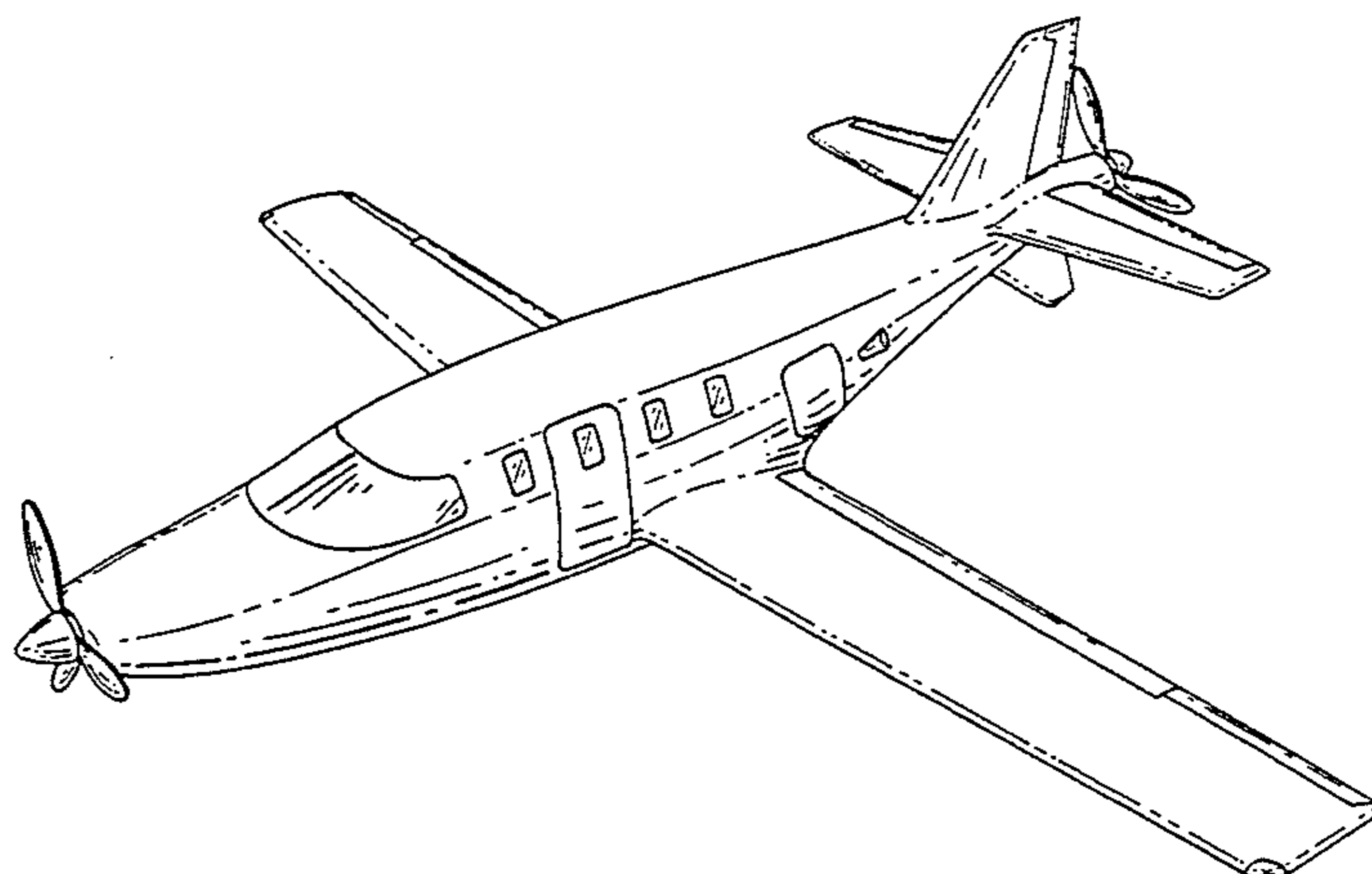

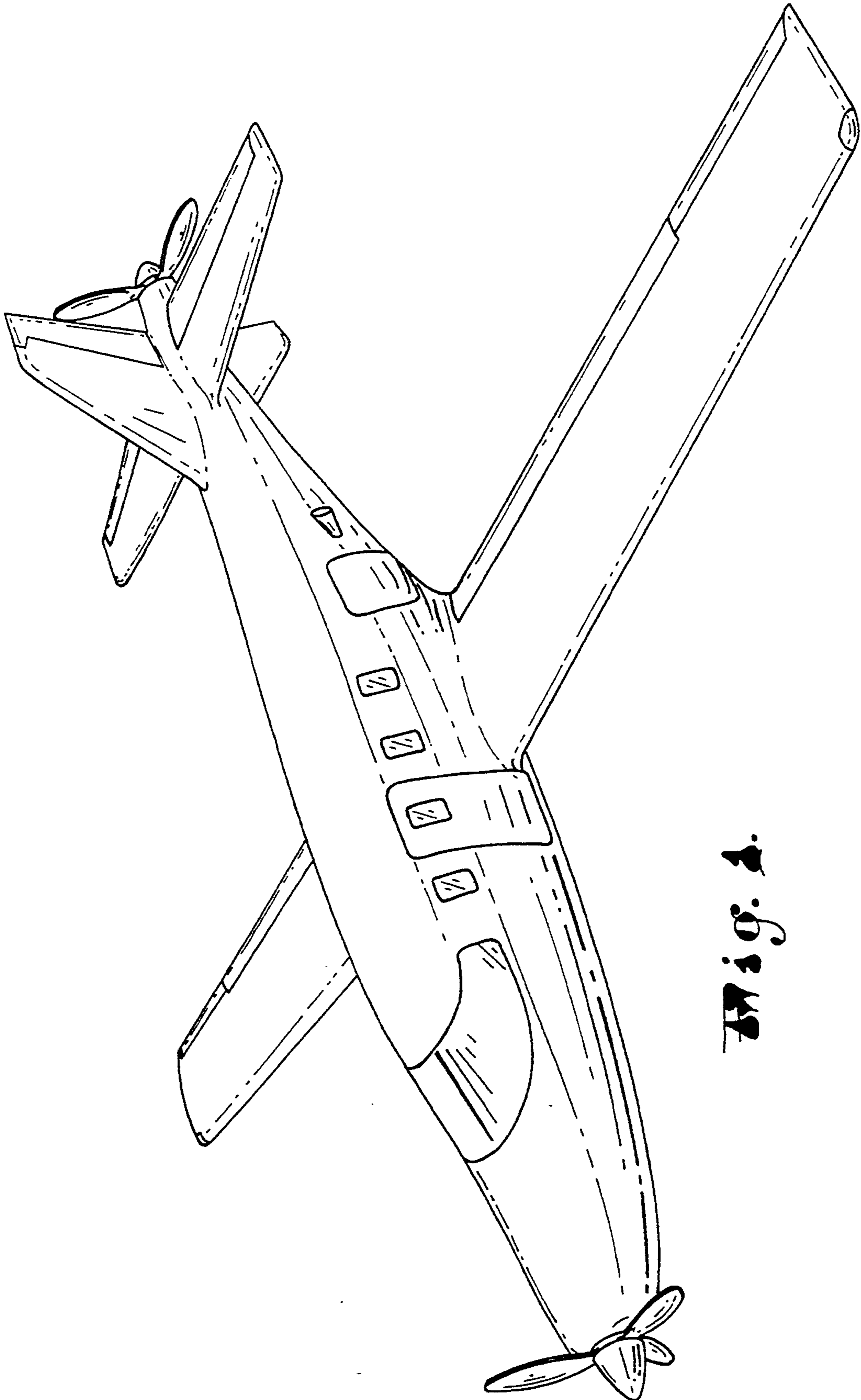

Fig. 1.

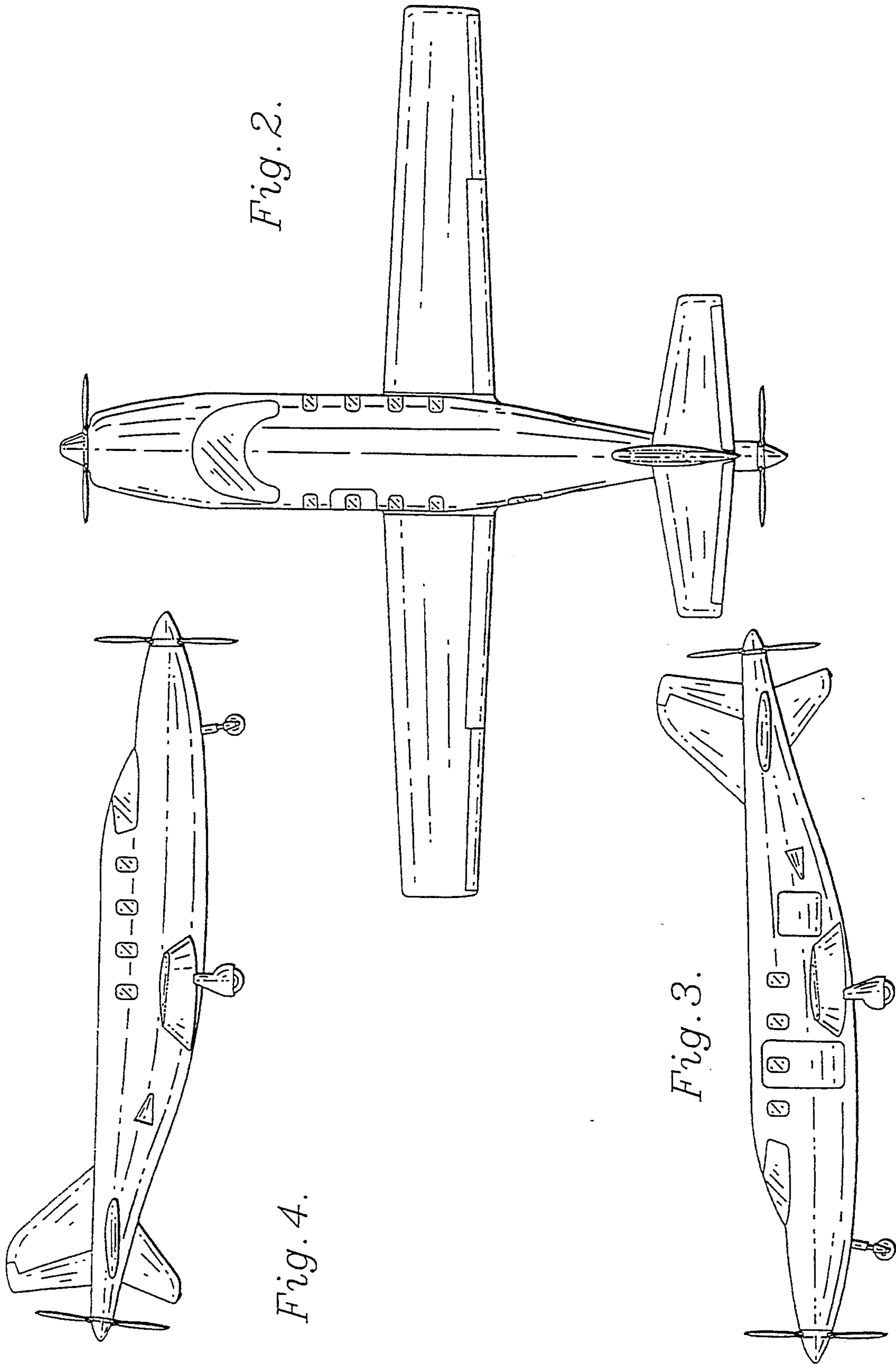

Fig. 5.

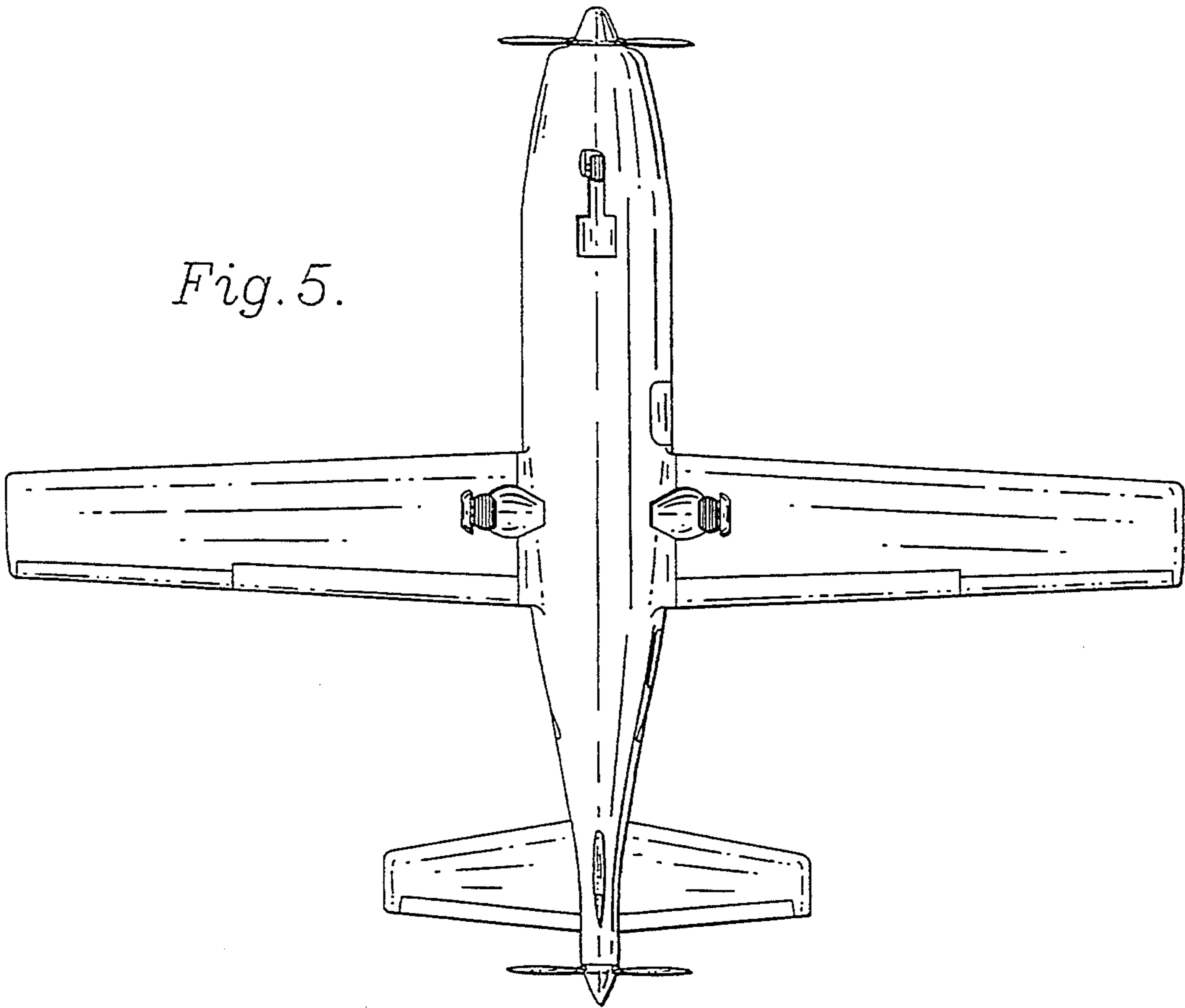

Fig. 6.

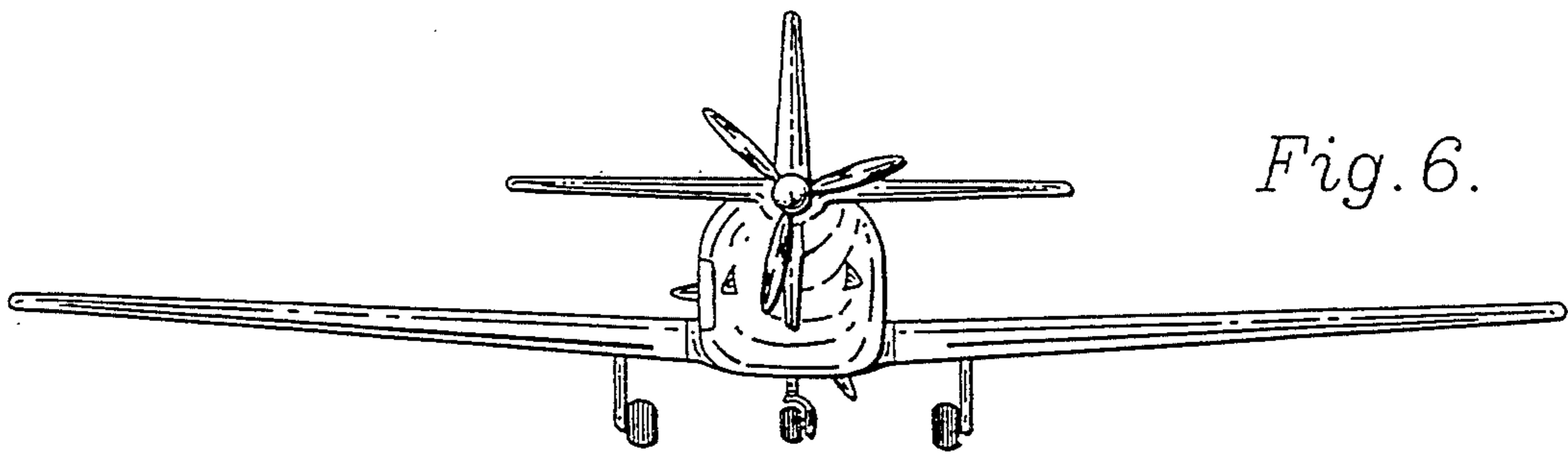

Fig. 7.

