



US00D354755S

United States Patent [19] Sparling

[11] Patent Number: **Des. 354,755**

[45] Date of Patent: **** Jan. 24, 1995**

[54] **AIRBORNE PUMP BOAT**

[76] Inventor: **Fred Sparling**, 122 Waterford Bridge Road, St. John's, Newfoundland, Canada, A1E 1C9

[**] Term: **14 Years**

[21] Appl. No.: **1,332**

[22] Filed: **Nov. 9, 1992**

[52] U.S. Cl. **D15/7**

[58] Field of Search **D15/7; 417/61, 410 B, 417/411, 40, 7, 423 K, 423; 114/183.12; 415/7**

[56] **References Cited**

U.S. PATENT DOCUMENTS

- 1,938,719 12/1933 Quimby 417/61
- 3,086,472 4/1963 Lorenzetti 417/61
- 4,780,063 10/1988 Tuckey 417/410 B

- 4,789,307 12/1988 Sloan 417/411
- 4,832,013 5/1989 Hartdorn 417/61

Primary Examiner—Ralf T. Seifert
Attorney, Agent, or Firm—Wenderoth, Lind & Ponack

[57] **CLAIM**

The ornamental design for an airborne pump boat, as shown and described.

DESCRIPTION

FIG. 1 is a top plan view of an airborne pump boat showing my new design;
FIG. 2 is a bottom plan view thereof;
FIG. 3 is a left side elevational view thereof;
FIG. 4 is a right side elevational view thereof;
FIG. 5 is a front elevational view thereof;
FIG. 6 is a rear elevational view thereof; and,
FIG. 7 is a left side elevational view thereof showing the rear stabilizer wings in a folded condition.

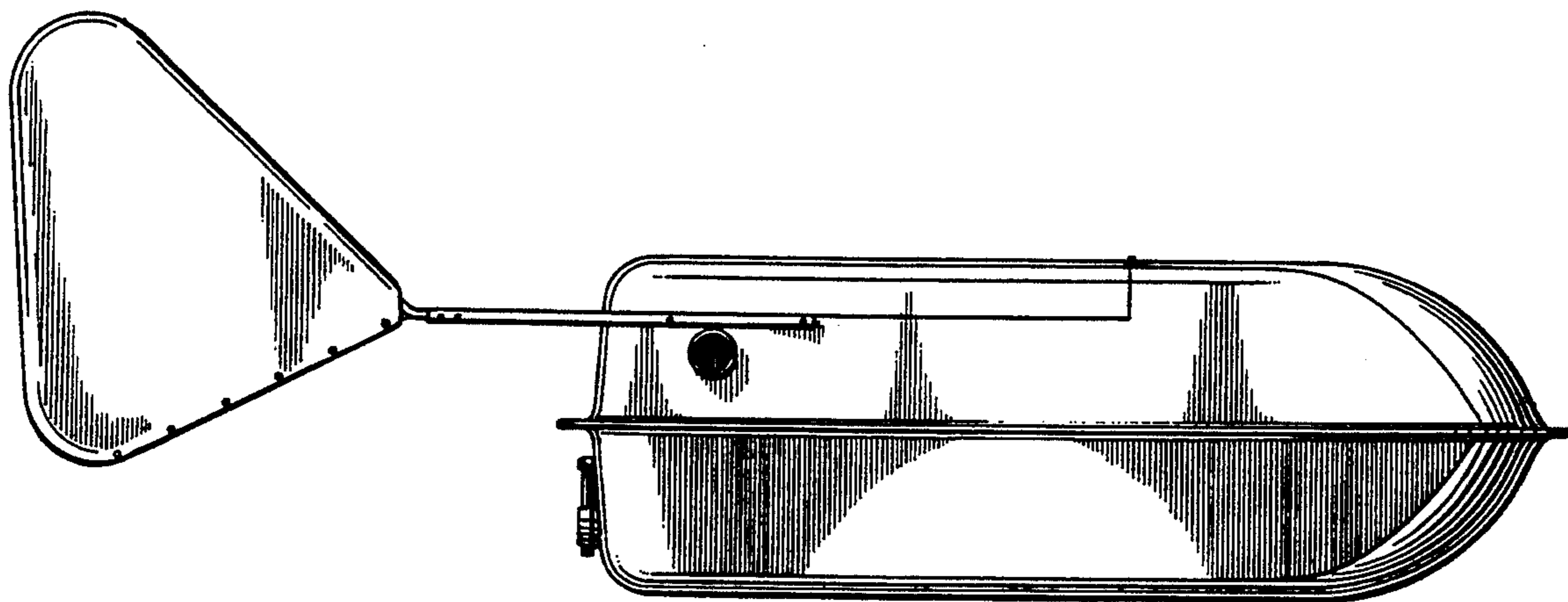

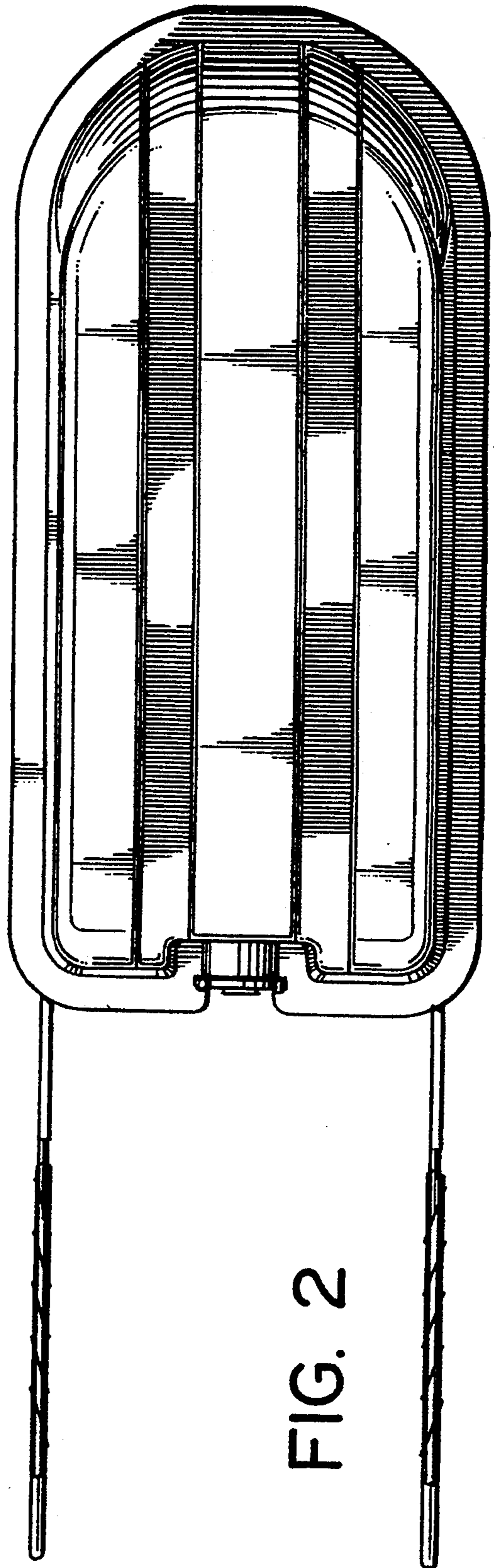
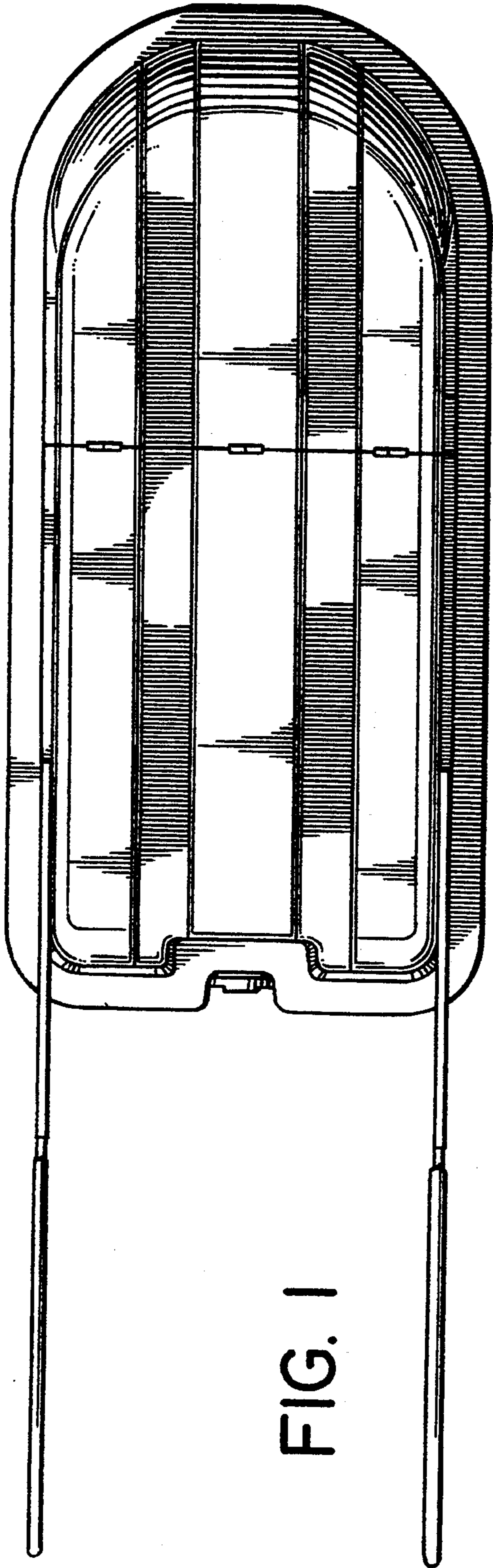

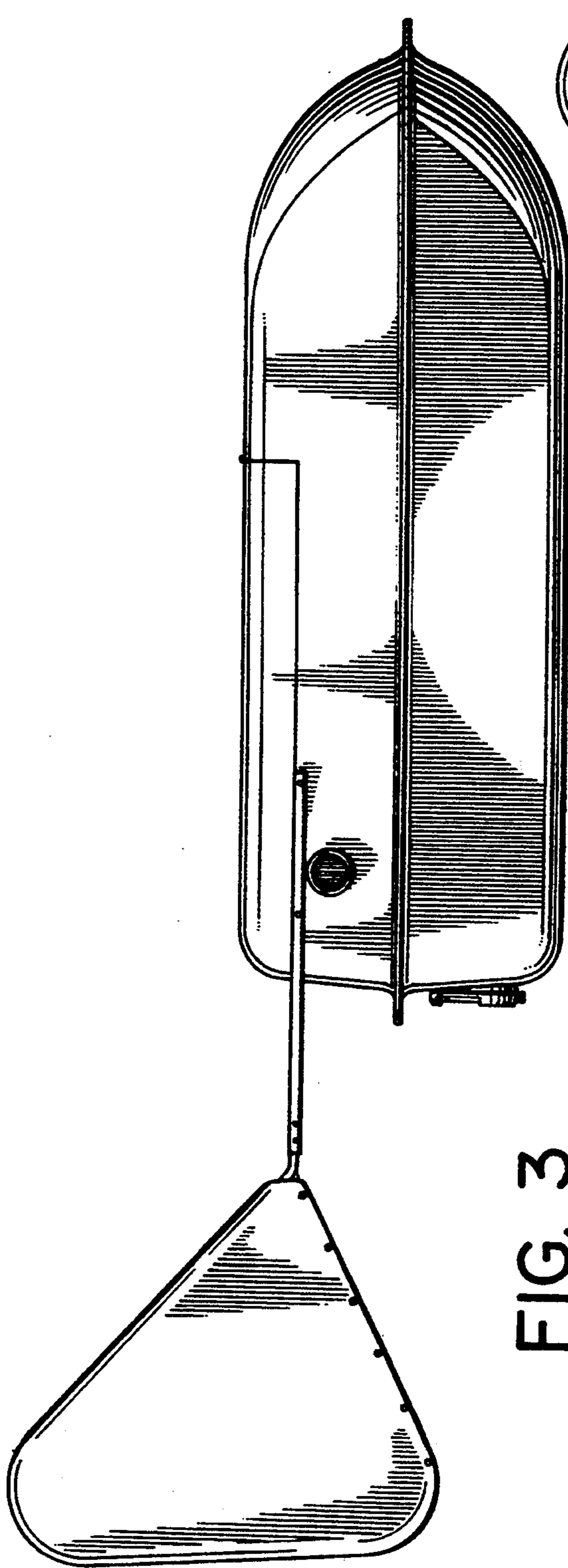

FIG. 3

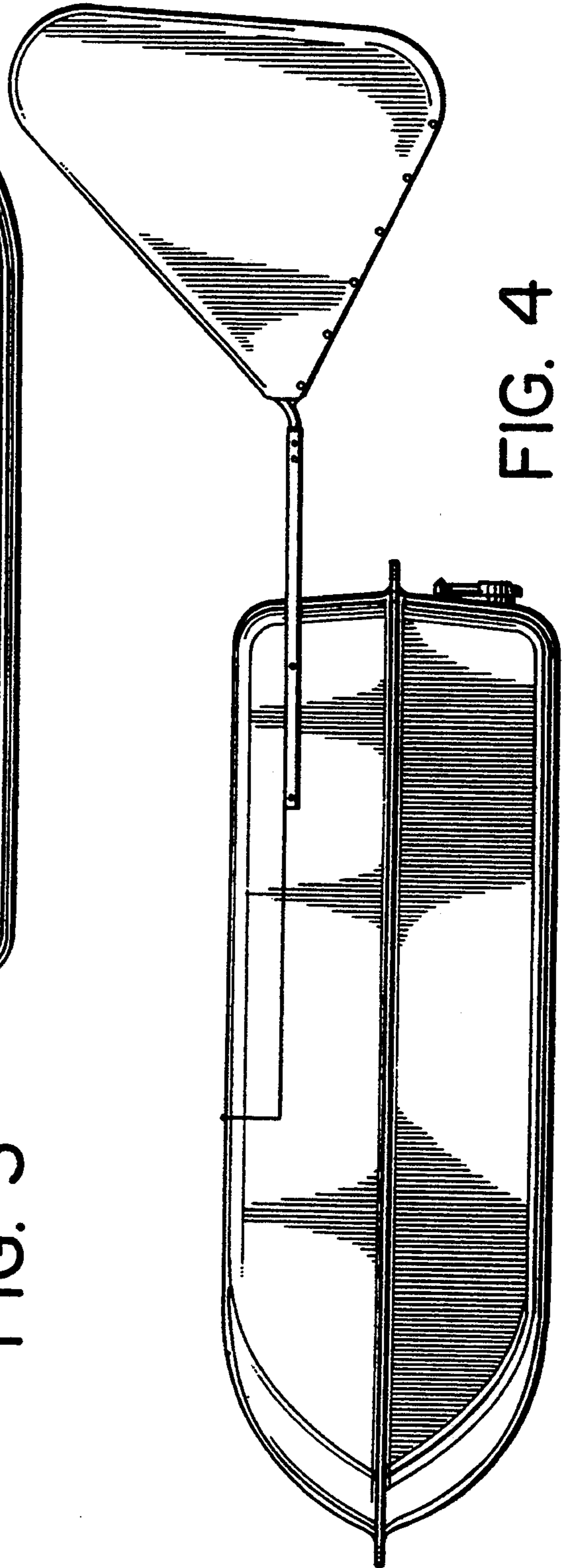

FIG. 4

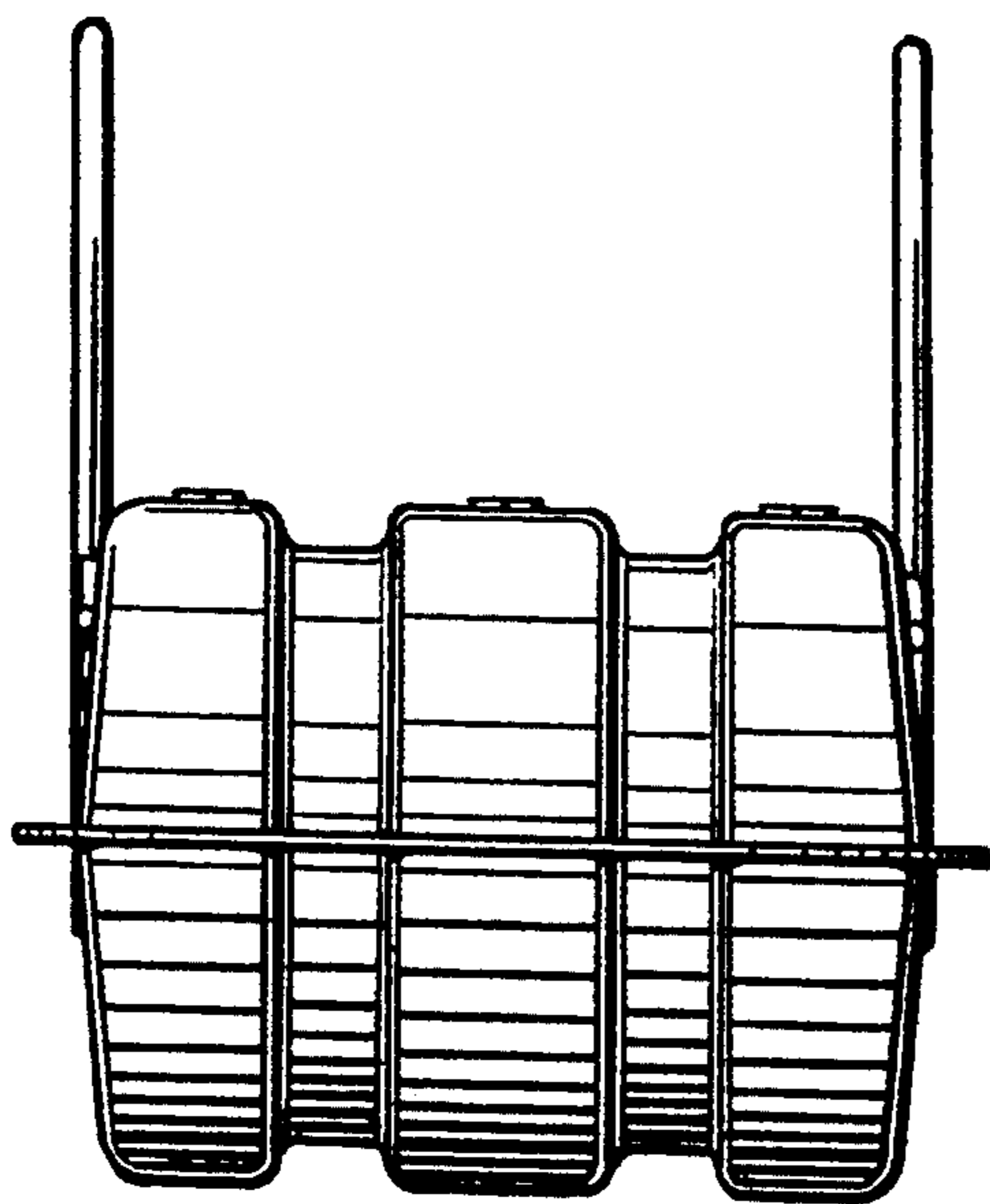

FIG. 5

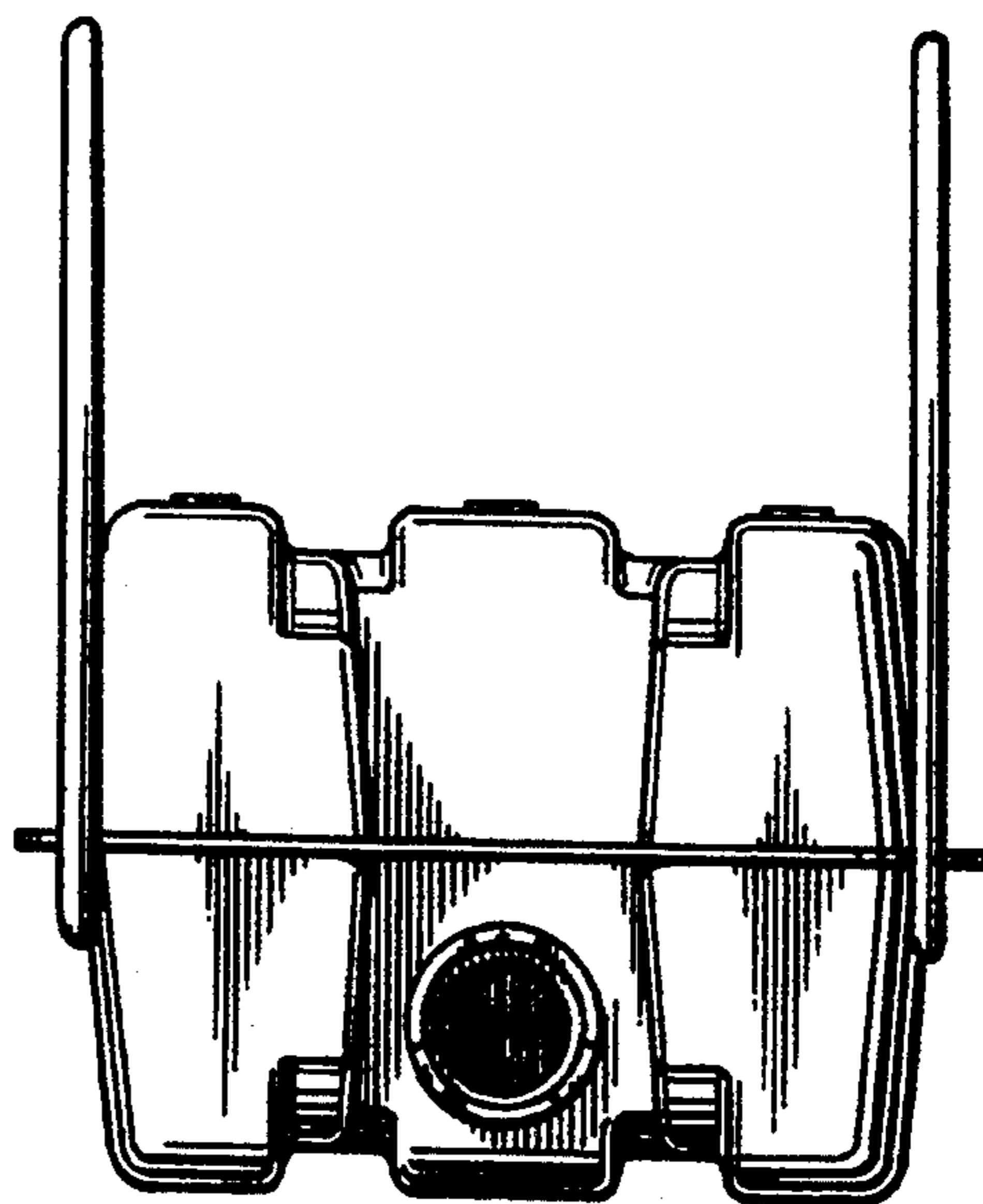

FIG. 6

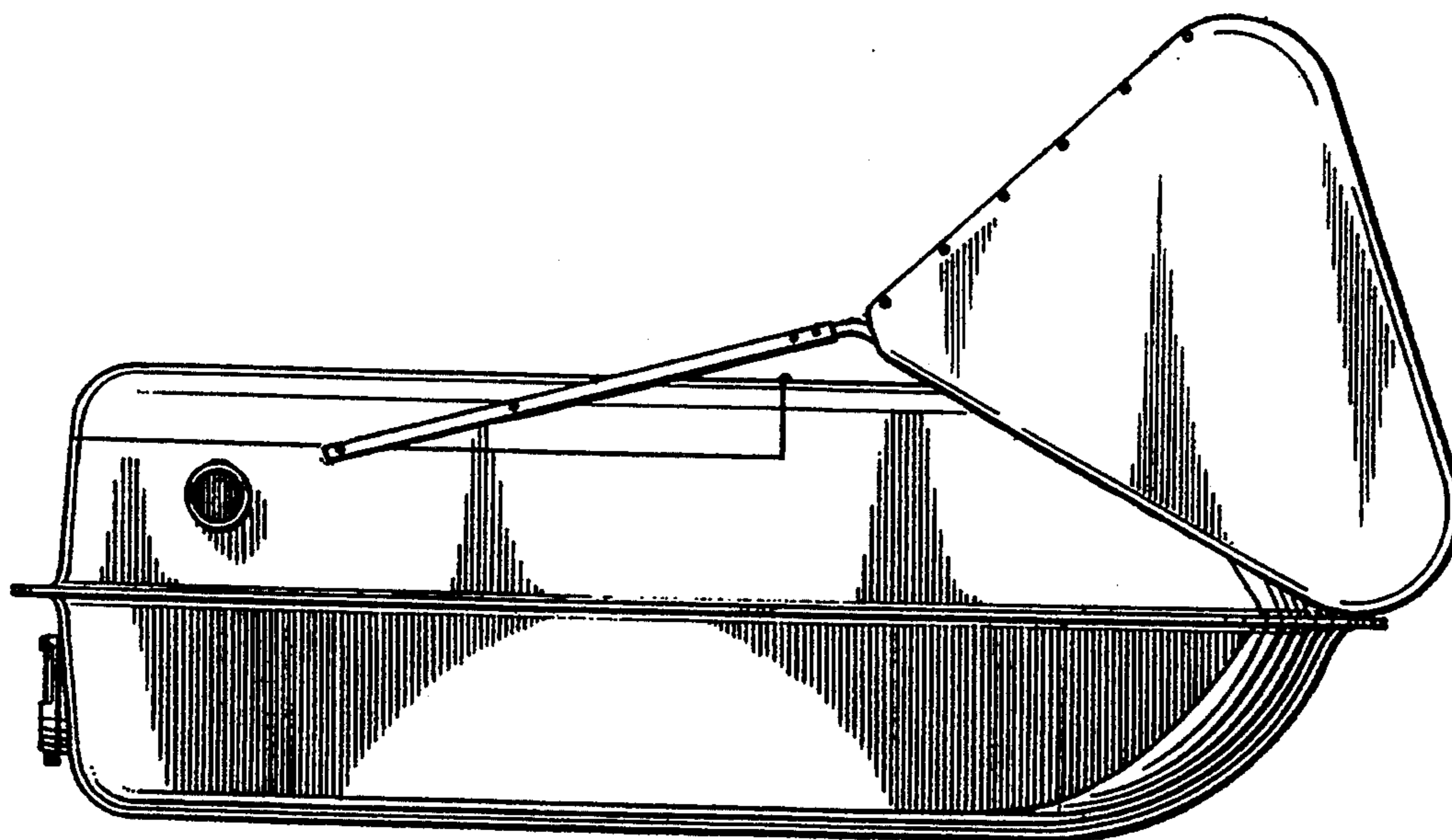

FIG. 7