



US00D354474S

# United States Patent [19]

[11] Patent Number: **Des. 354,474**

Murphy et al.

[45] Date of Patent: **\*\* Jan. 17, 1995**

[54] **DOUBLE DECKED AIRPLANE**

*Attorney, Agent, or Firm*—Donald E. Stout; John P. Scholl

[75] Inventors: **David G. Murphy**, Los Alamitos, Calif.; **John H. Lindley**, Baldwin, Md.; **Neil M. Jerstad**, Long Beach; **Edward A. Wen**, both of Long Beach; **Norman T. L. Fraser**, Seal Beach, all of Calif.

[57] **CLAIM**

The ornamental design for a double decked airplane, as shown and described.

[73] Assignee: **McDonnell Douglas Corporation**, Huntington Beach, Calif.

**DESCRIPTION**

[\*\*] Term: **14 Years**

FIG. 1 is a right side perspective view of a first four engined embodiment of a double decked airplane showing our new design;

[21] Appl. No.: **6,456**

FIG. 2 is a left side elevational view thereof;

[22] Filed: **Mar. 30, 1993**

FIG. 3 is a front elevational view thereof;

[52] U.S. Cl. .... **D12/340; D12/319**

FIG. 4 is a top plan view thereof;

[58] Field of Search ..... **D12/319, 341, 340, 343; 244/119, 118.5, 130, 45 R, 35 A**

FIG. 5 is a right side perspective view of a second four engined embodiment of a double decked airplane showing our new design;

[56] **References Cited**

**U.S. PATENT DOCUMENTS**

5,115,999 5/1992 Buchsel et al. .... 244/119

FIG. 6 is a left side elevational view of the FIG. 5 embodiment;

**OTHER PUBLICATIONS**

Aviation Week & Space Technology, Nov. 9, 1981, Boeing 747 transport aircraft.

FIG. 7 is a top plan view of the FIG. 5 embodiment;

FIG. 8 is a front elevational view of the FIG. 5 embodiment;

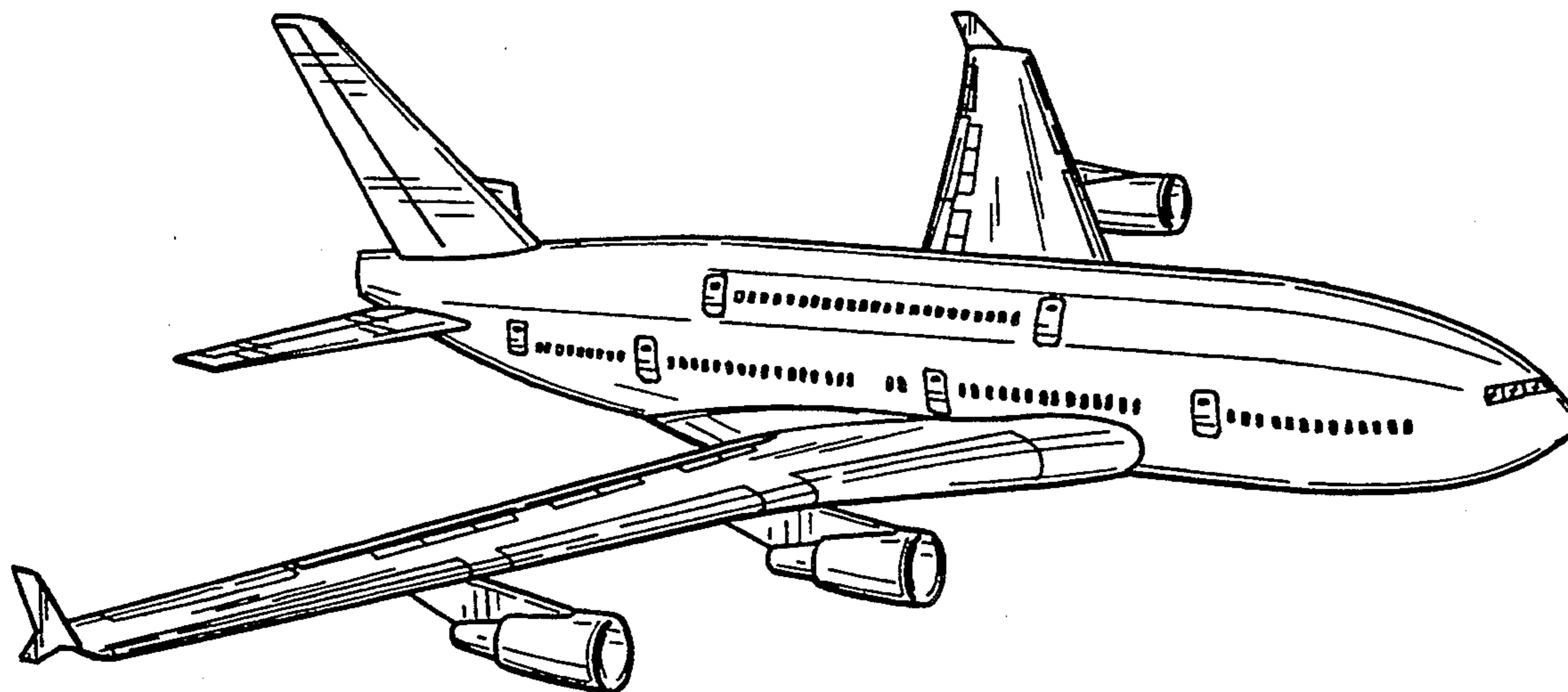
FIG. 9 is a right side perspective view of a third two engined embodiment of a double decked airplane showing our new design;

FIG. 10 is a left side elevational view of the FIG. 9 embodiment;

FIG. 11 is a top plan view of the FIG. 9 embodiment; and,

FIG. 12 is a front elevational view of the FIG. 9 embodiment.

*Primary Examiner*—Kay H. Chin



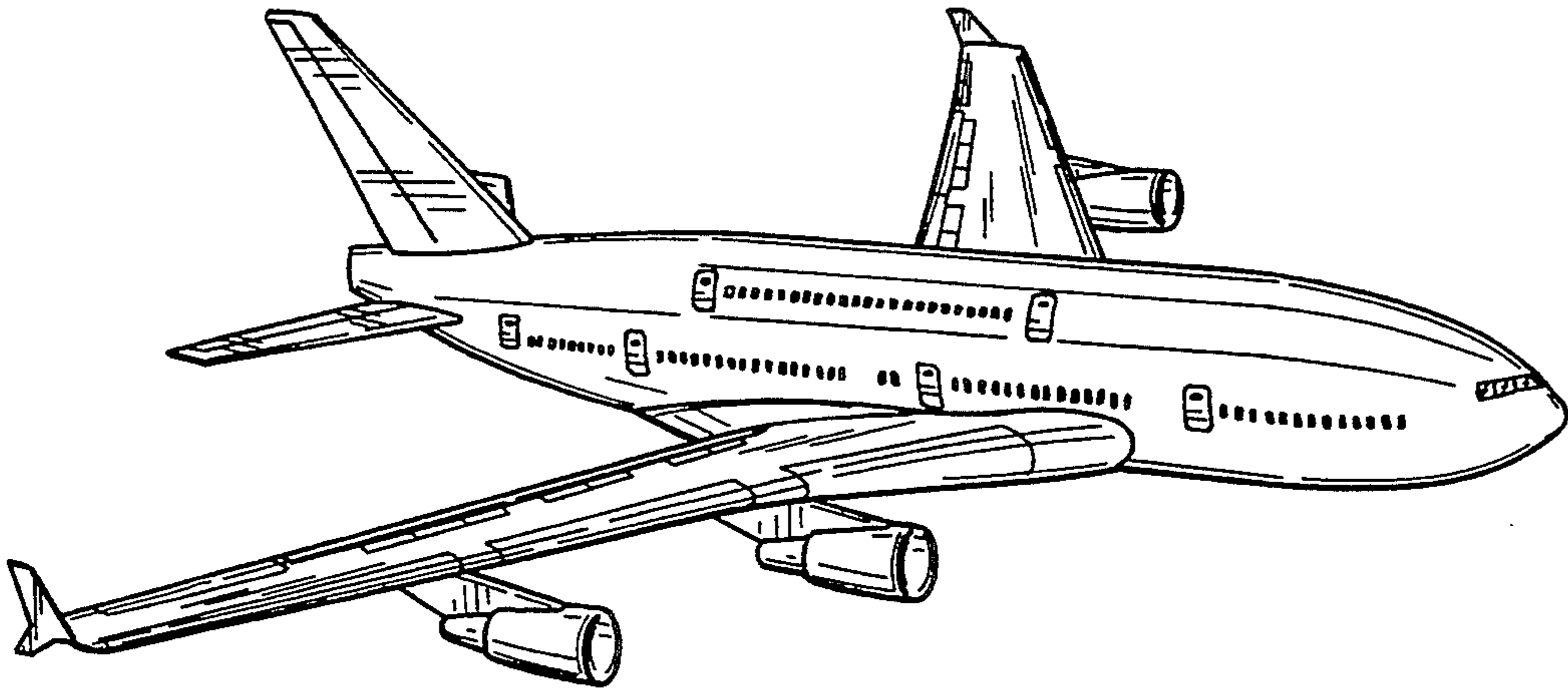


Fig. 1

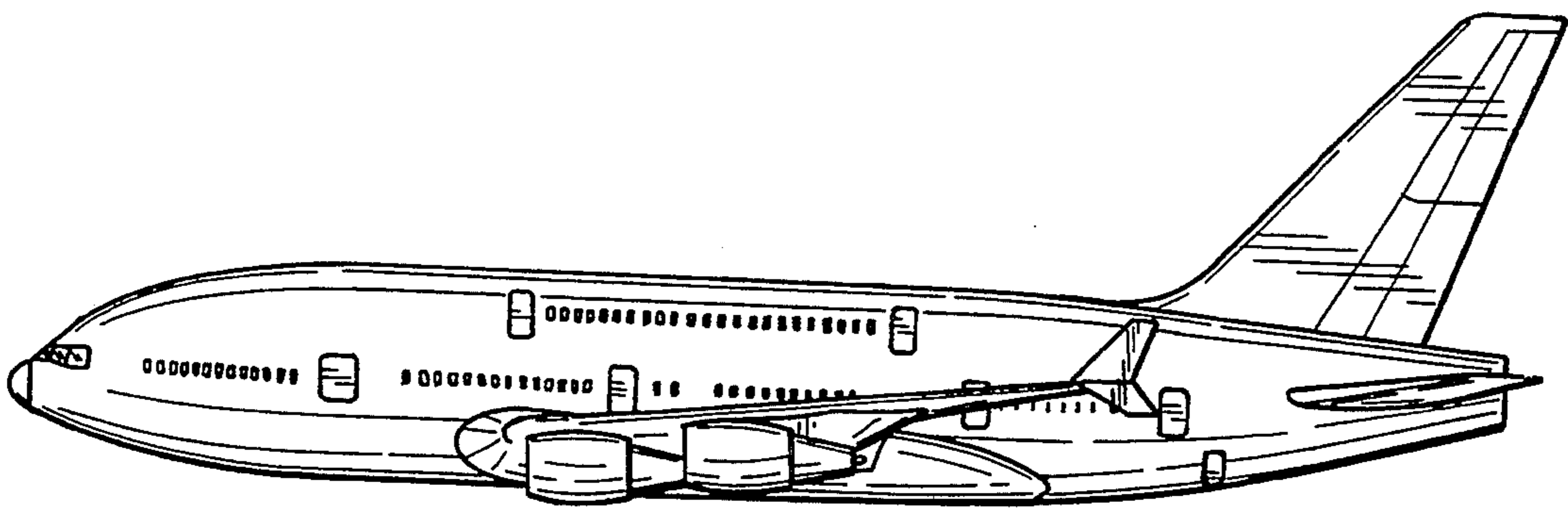


Fig. 2

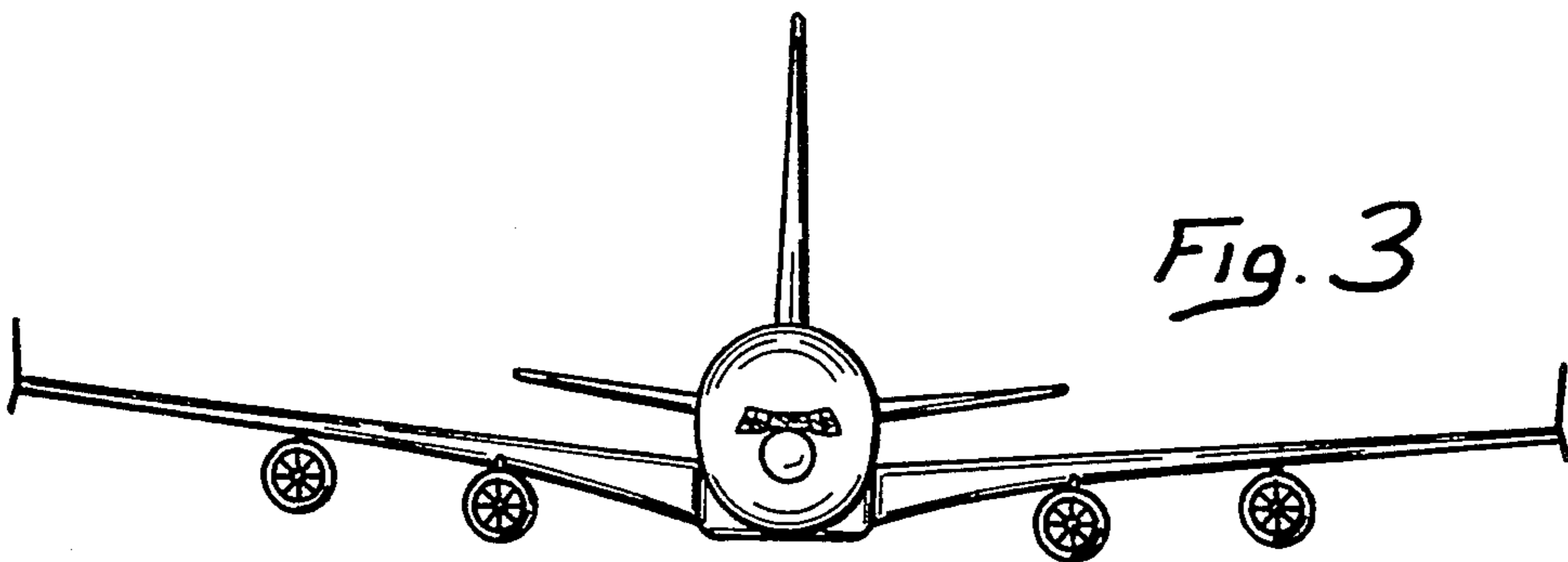
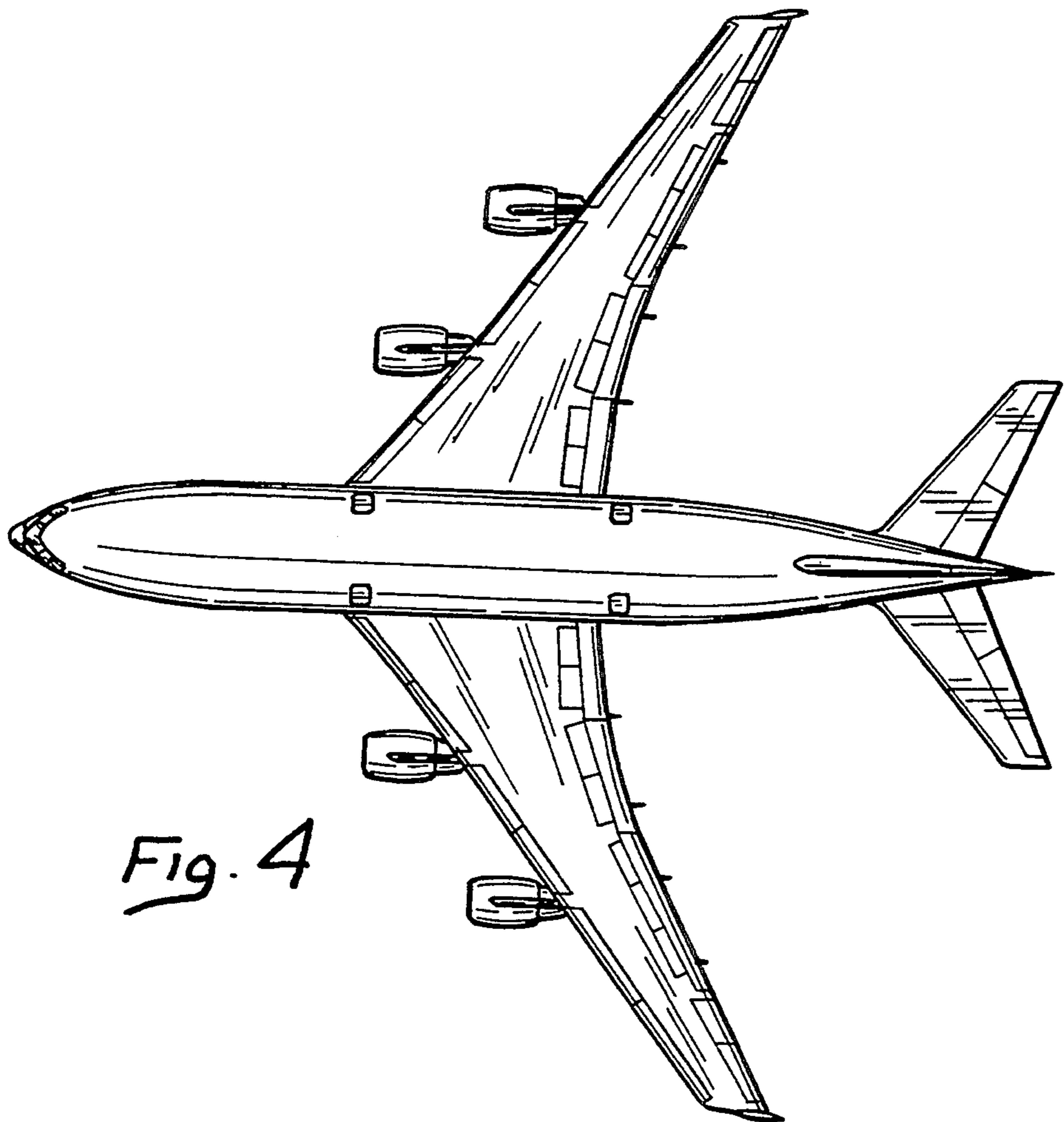
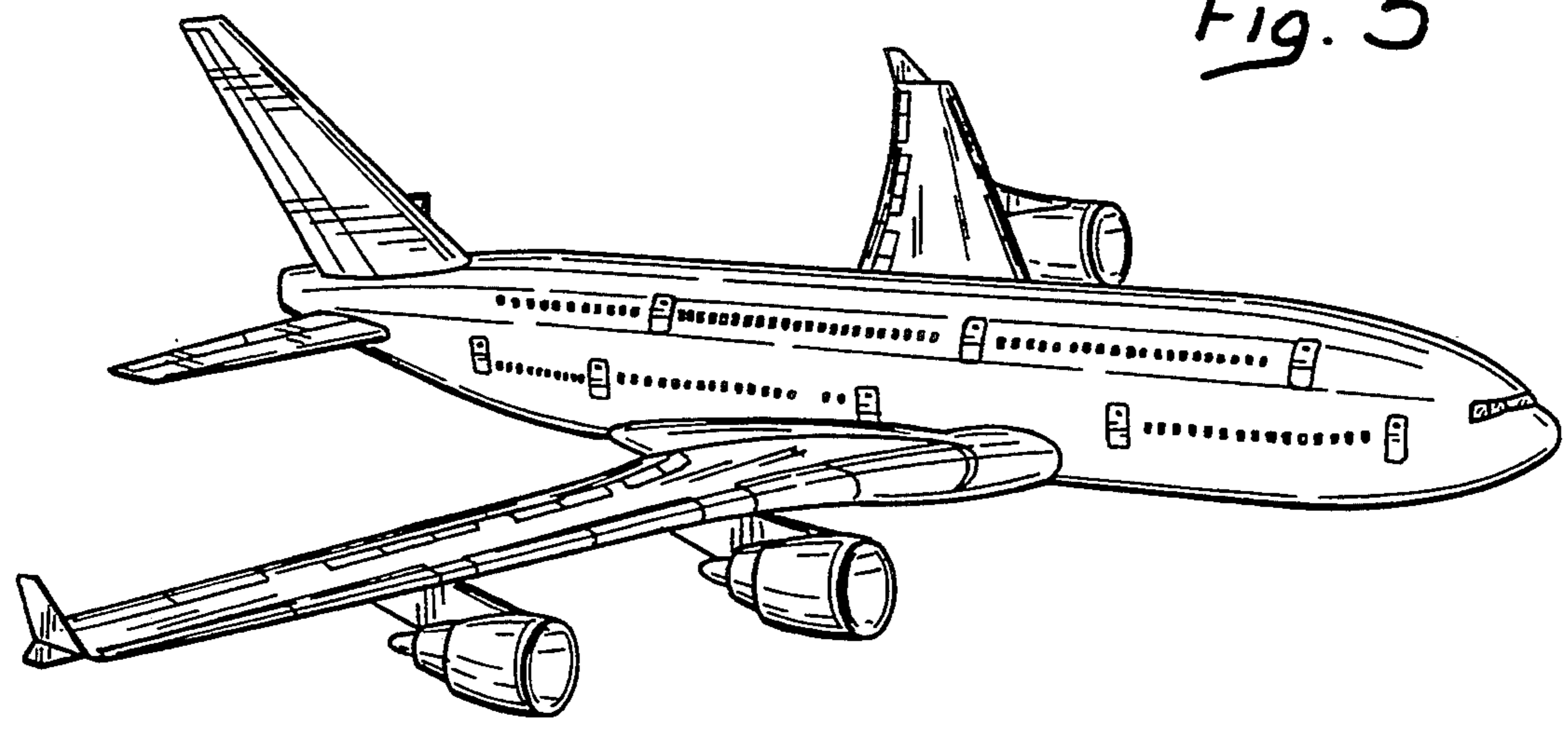


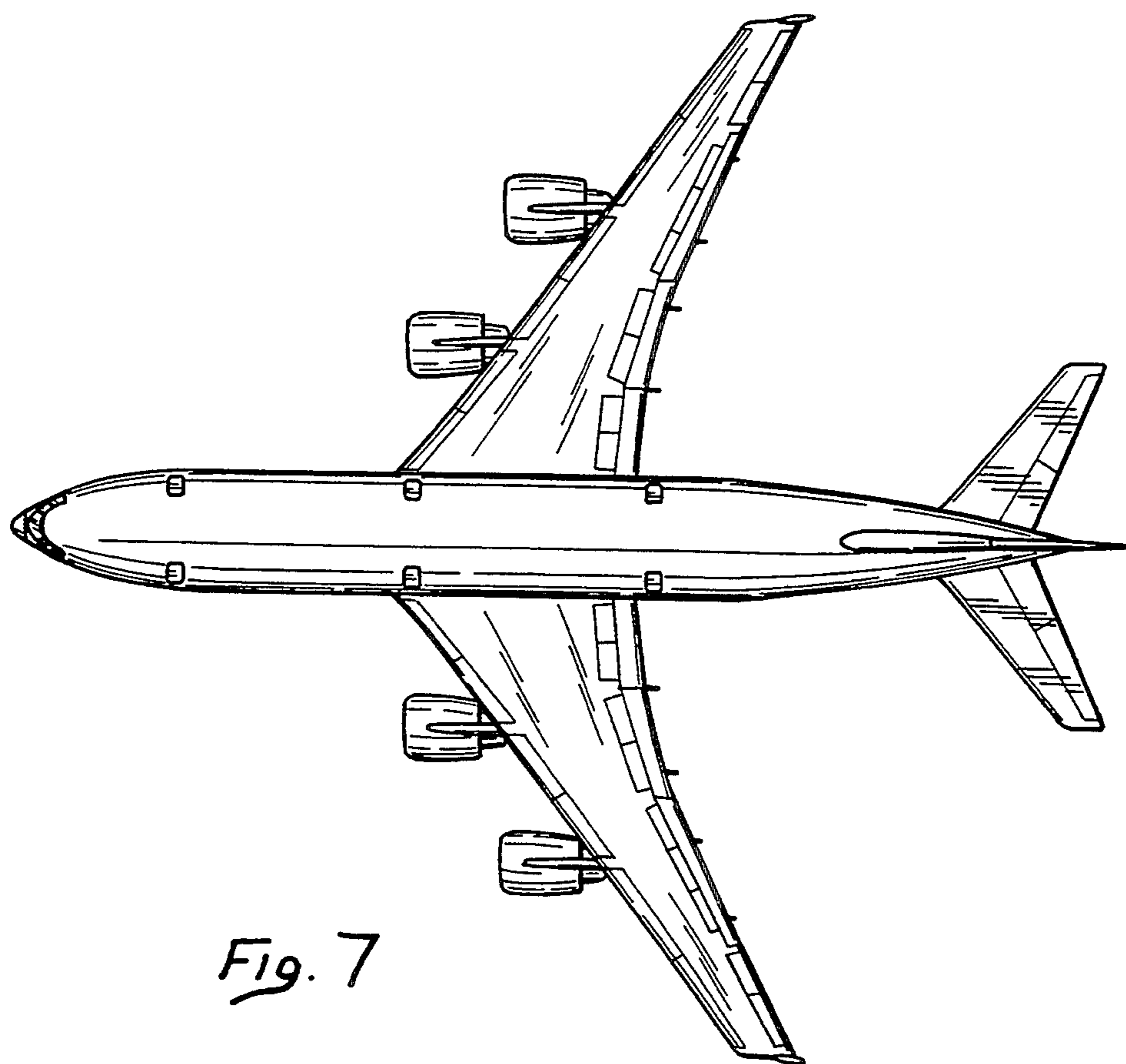
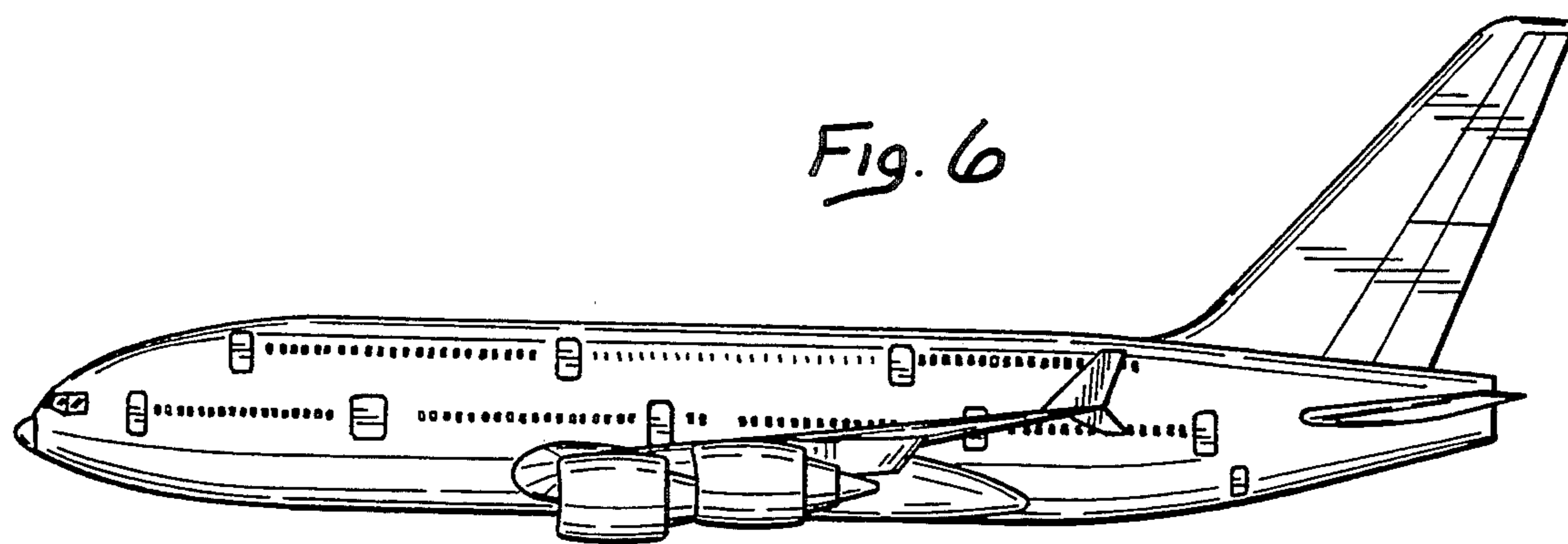
Fig. 3

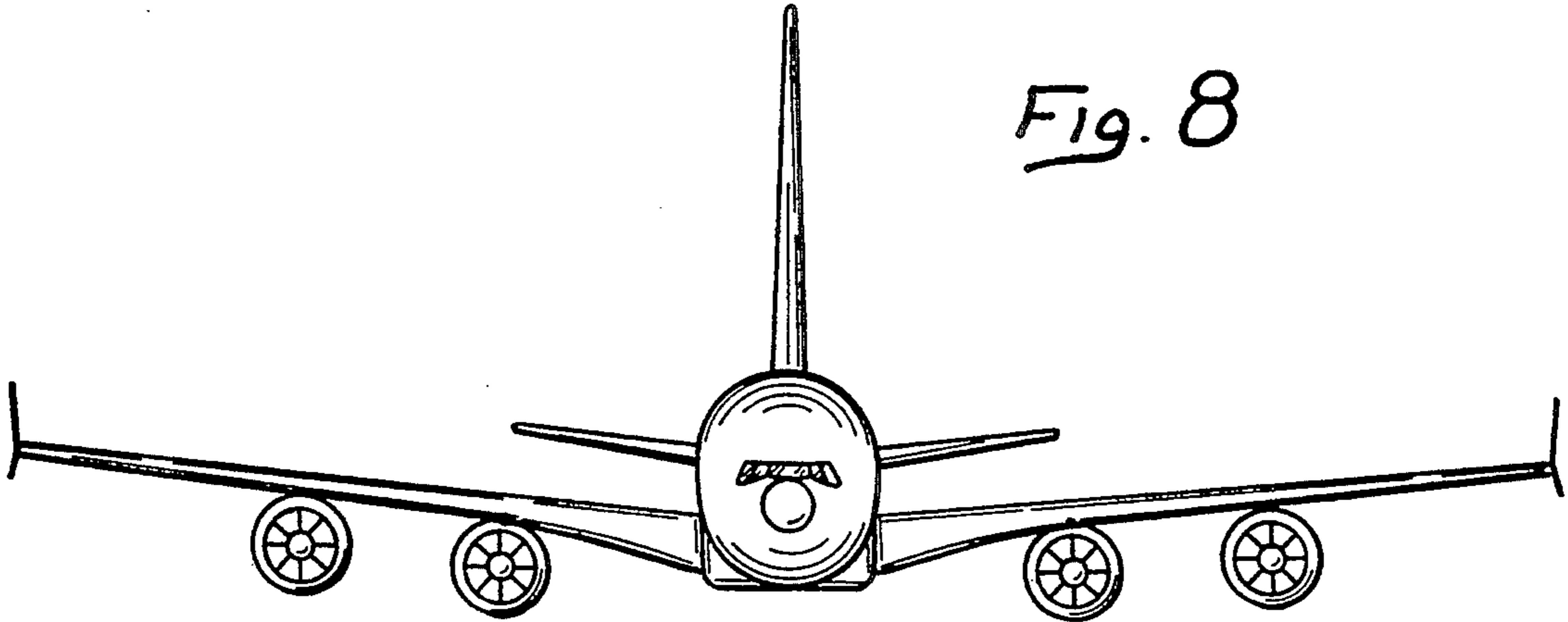


*Fig. 4*

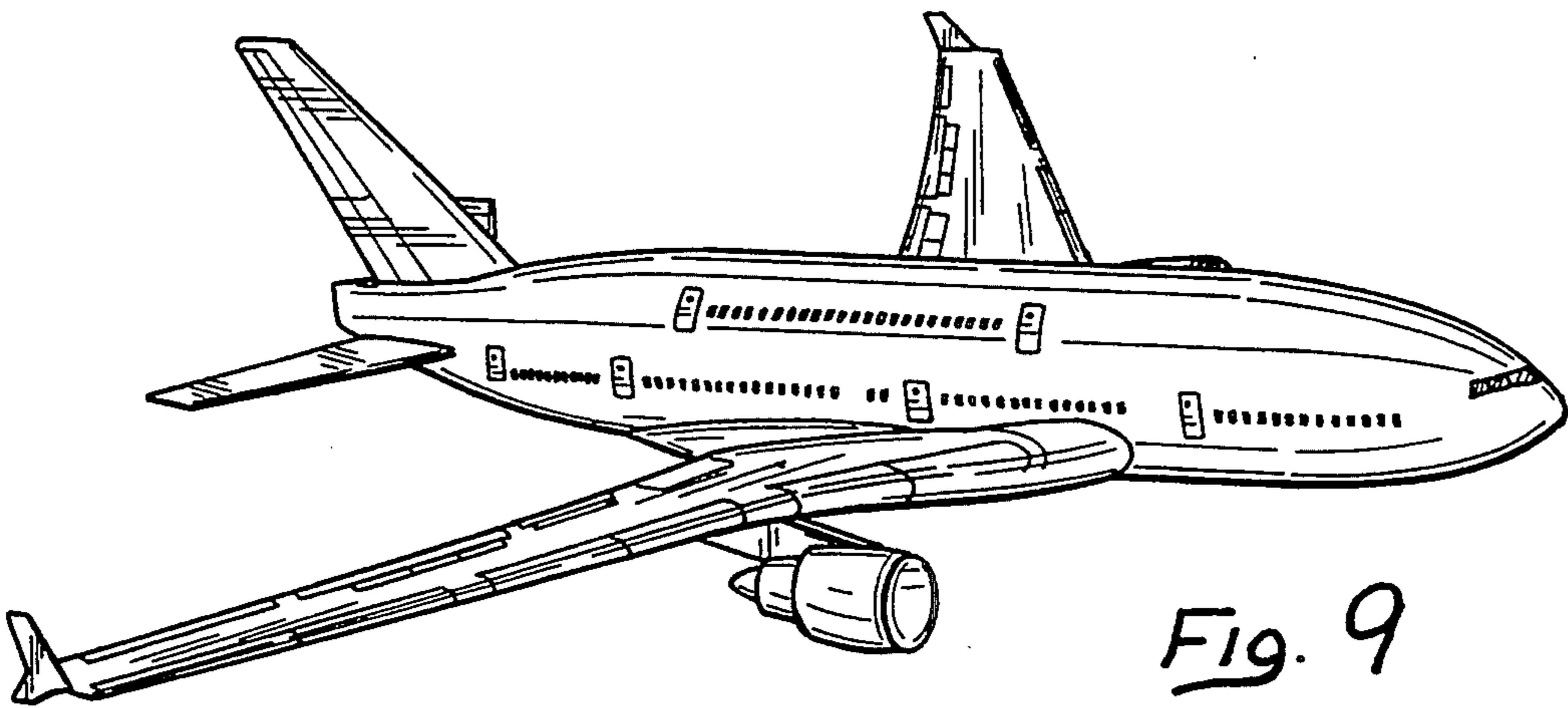


*Fig. 5*

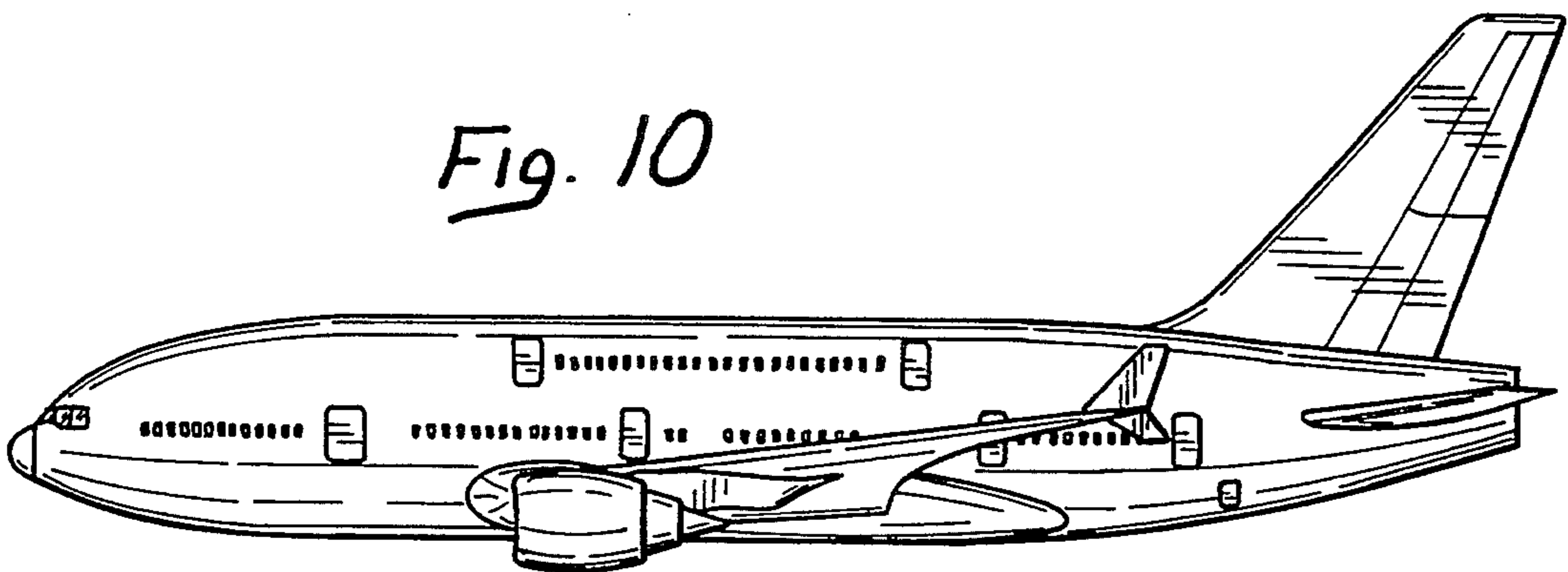




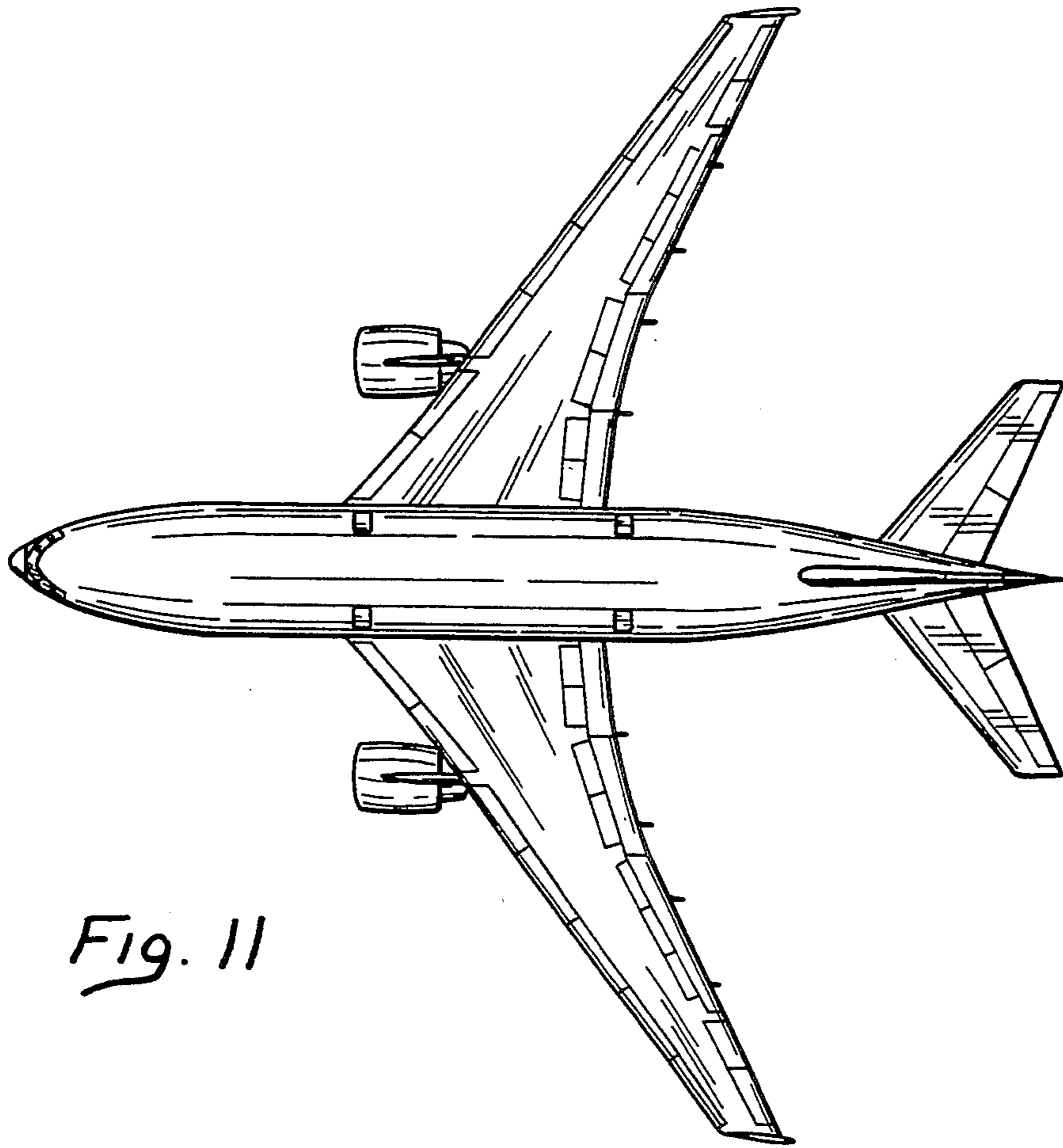
*Fig. 8*



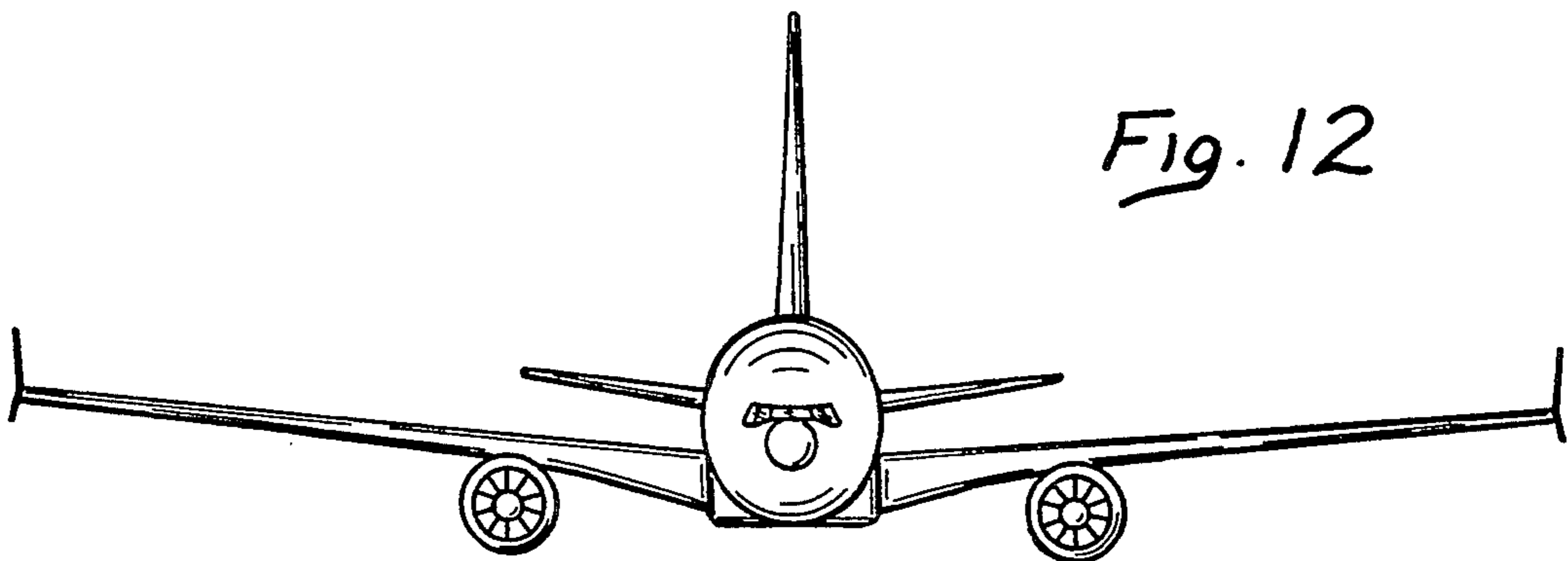
*Fig. 9*



*Fig. 10*



*Fig. 11*



*Fig. 12*