



US00D354259S

United States Patent [19]

Kurke et al.

[11] Patent Number: Des. 354,259

[45] Date of Patent: ** Jan. 10, 1995

[54] BICYCLE STEM

5,241,881 9/1993 Chen 74/551.2

[76] Inventors: **Martin I. Kurke**, 121 Penn St., El Segundo, Calif. 90245; **Bob Morales**, 19962 Lexington Ave., Huntington Beach, Calif. 92646

[**] Term: 14 Years

[21] Appl. No.: 11,059

[22] Filed: Jul. 26, 1993

[52] U.S. Cl. D12/118

[58] Field of Search D12/118; 74/551.1, 551.2, 74/551.3; 280/279

OTHER PUBLICATIONS

American Bicyclist & Motorcyclist, Sep. 1992, p. 73, the Dirt Research Bicycle Stem.

Primary Examiner—Wallace R. Burke
Assistant Examiner—Melody Brown
Attorney, Agent, or Firm—Erik M. Arnhem

[57] CLAIM

The ornamental design for a bicycle stem, as shown and described.

DESCRIPTION

FIG. 1 is a perspective view of a bicycle stem, showing our new design;

FIG. 2 is a top view;

FIG. 3 is a bottom view;

FIG. 4 is a right side view thereof;

FIG. 5 is a left side view thereof;

FIG. 6 is a front view thereof; and,

FIG. 7 is a rear view thereof.

[56] References Cited

U.S. PATENT DOCUMENTS

D. 253,589	12/1979	Horton	D12/118
D. 306,418	3/1990	McMurtrey	D12/118
D. 341,801	11/1993	McCormack et al.	D12/118
4,939,950	7/1990	Girven	74/551.1
5,199,322	4/1993	Wu	74/551.1

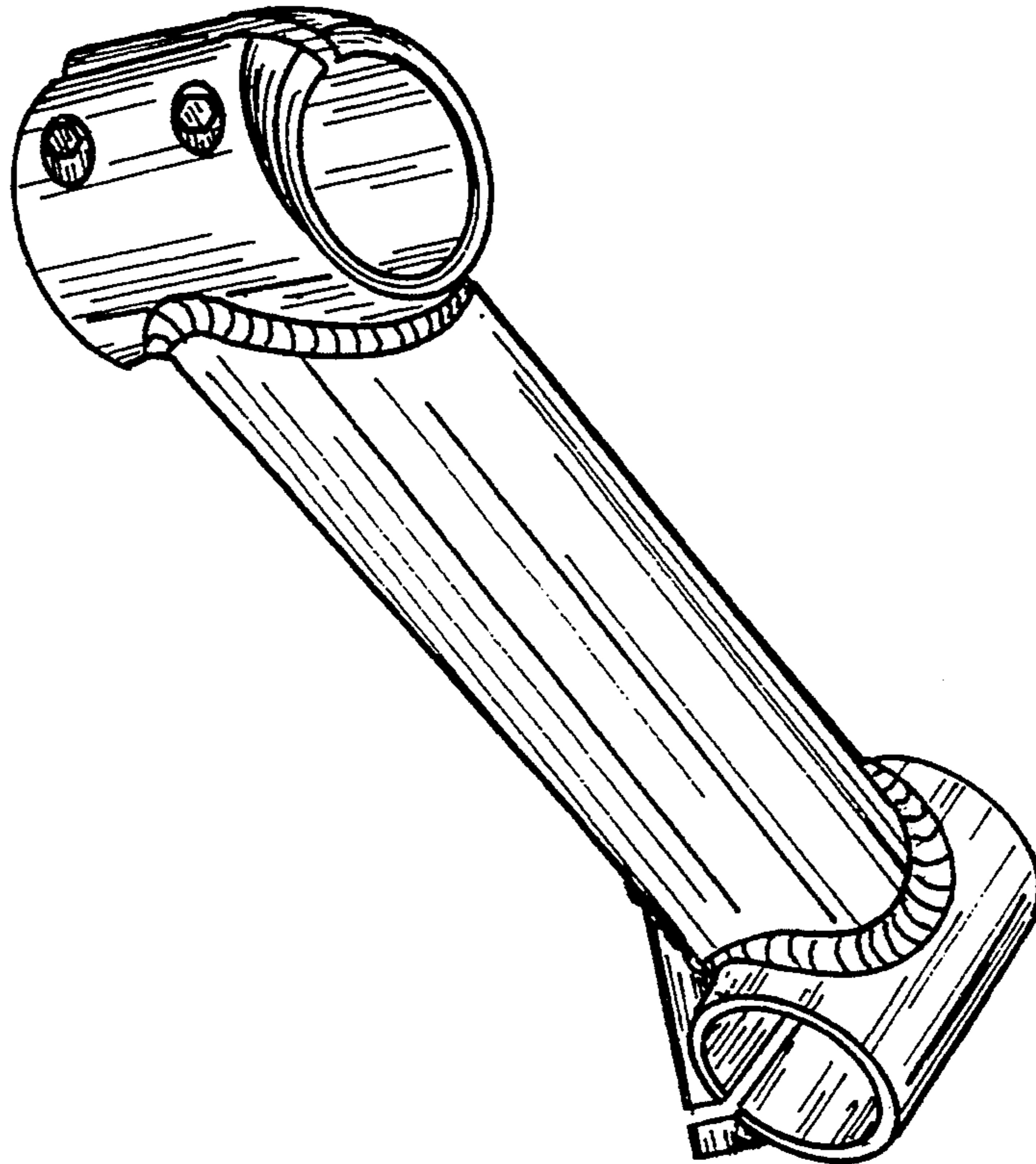

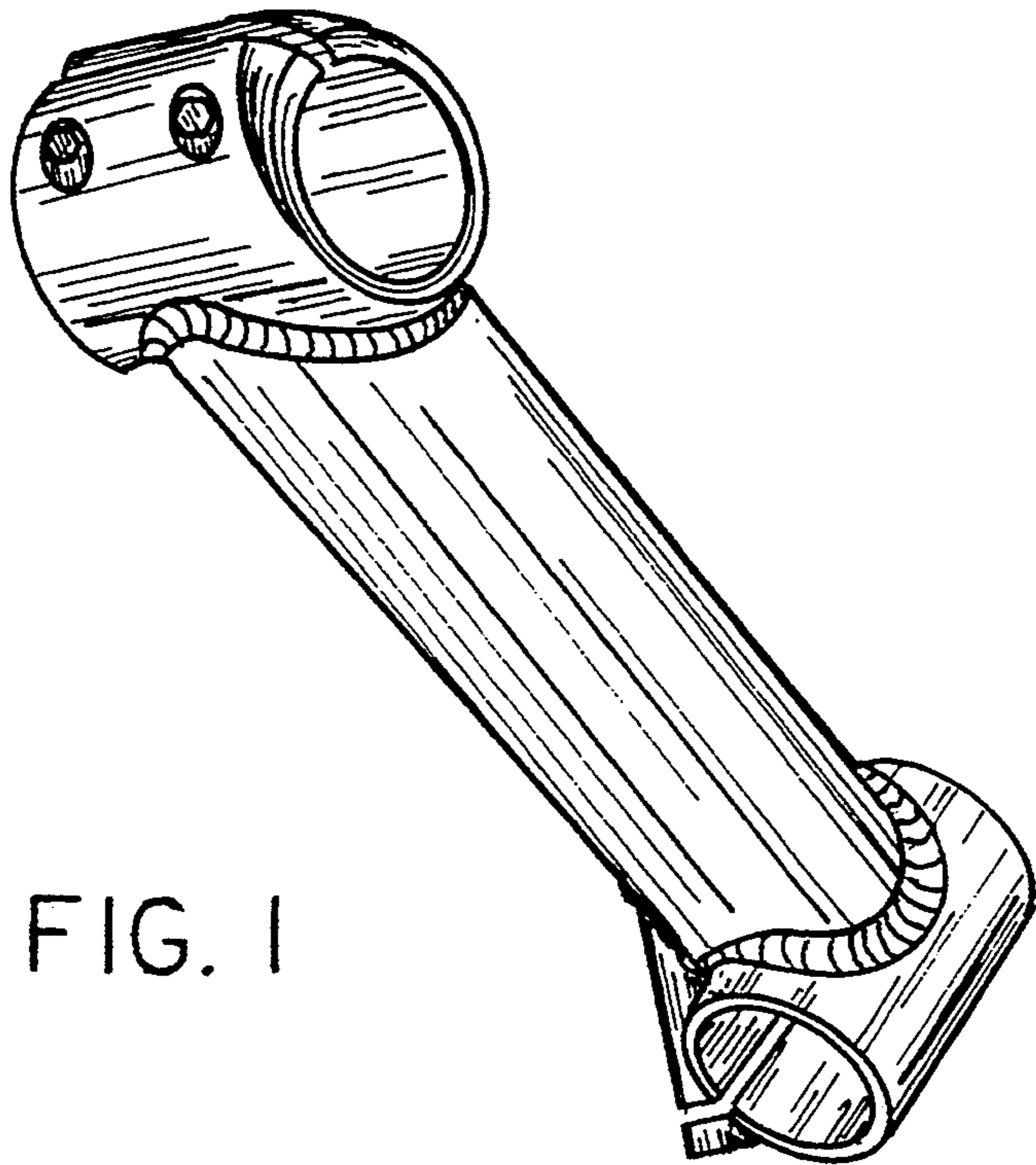

FIG. 1

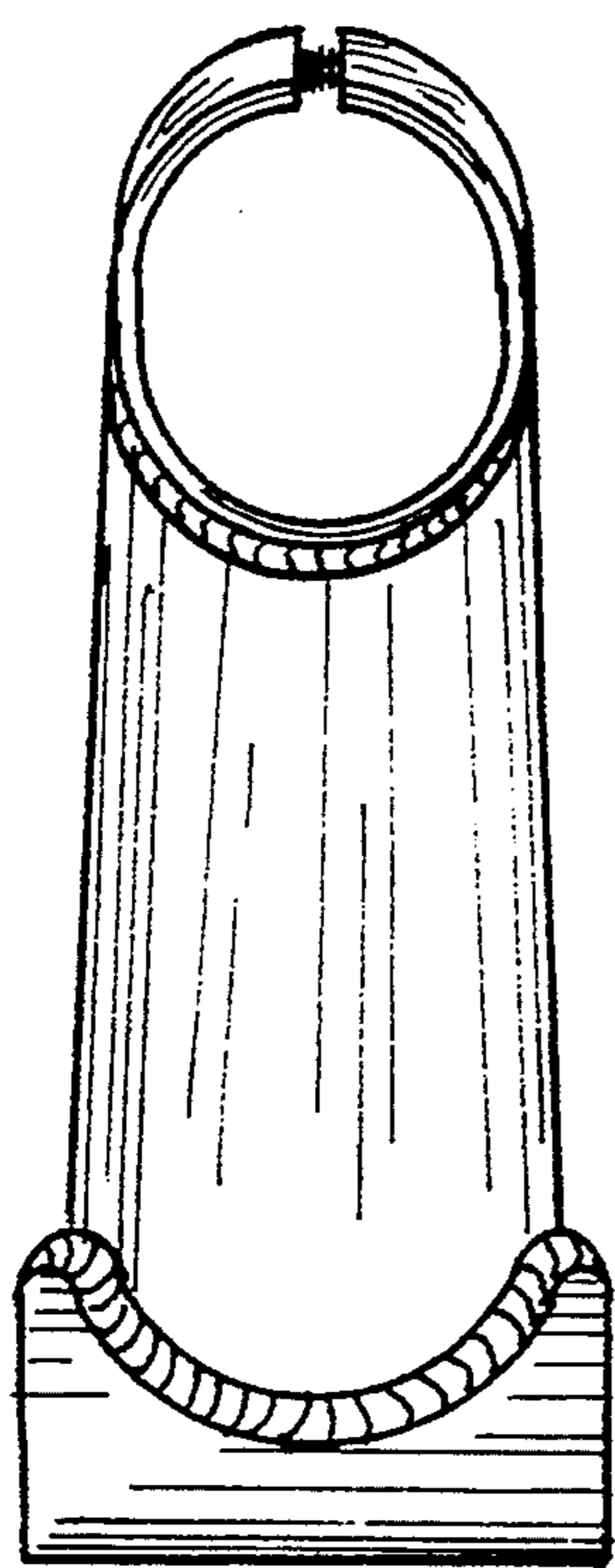

FIG. 2

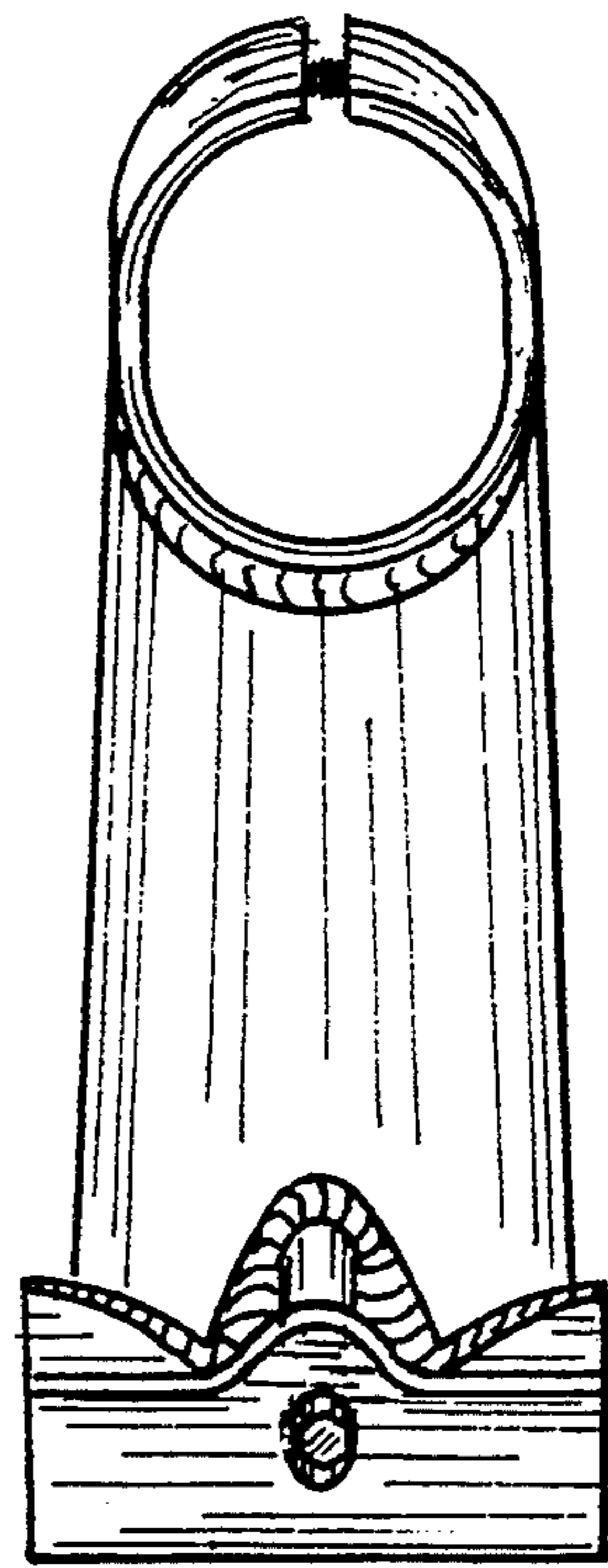

FIG. 3

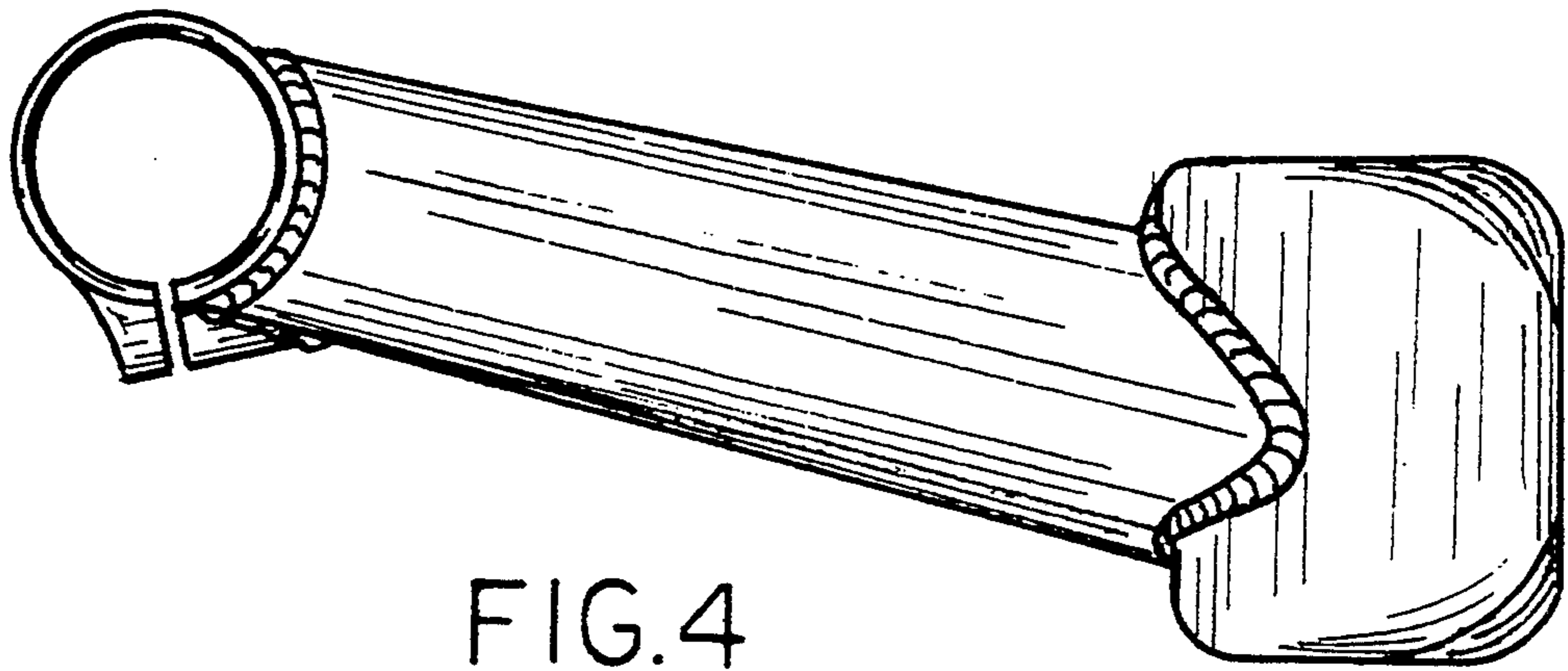

FIG. 4

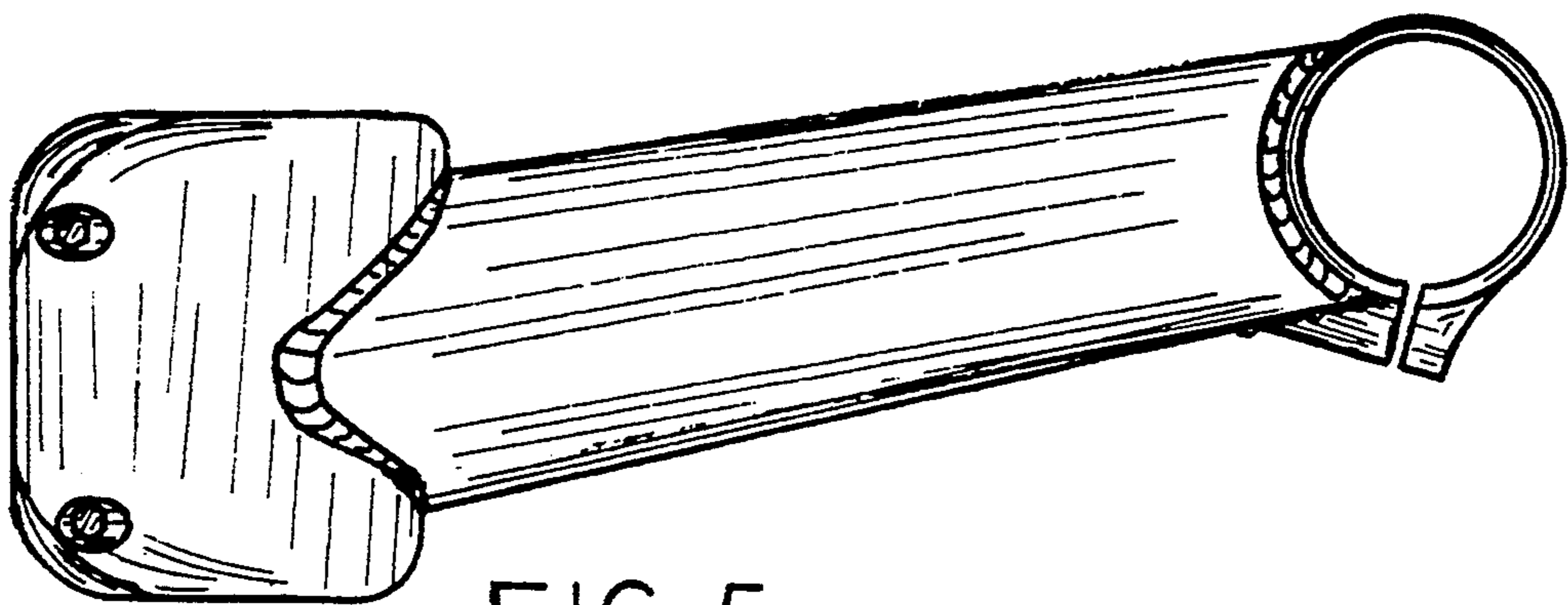

FIG. 5

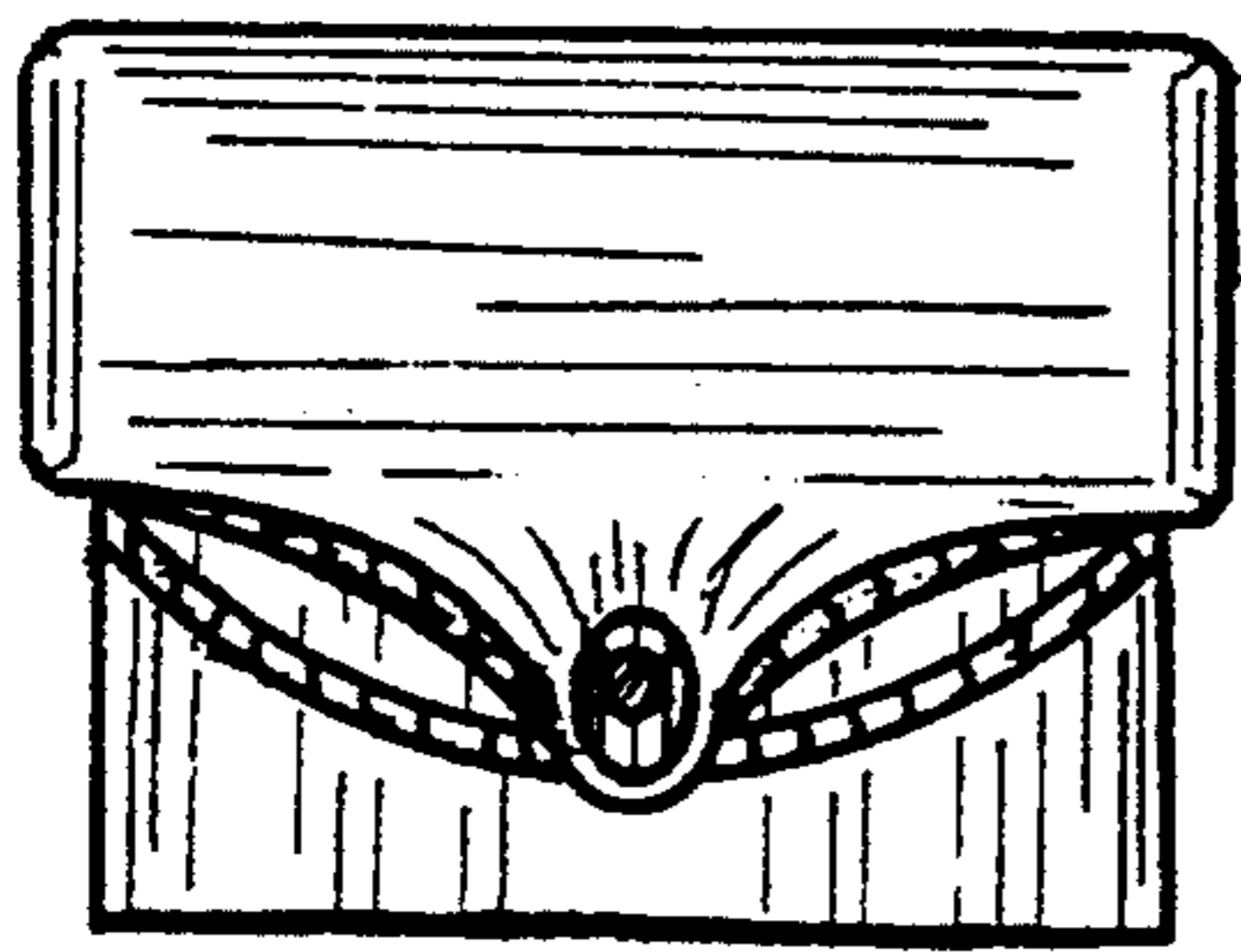

FIG. 6

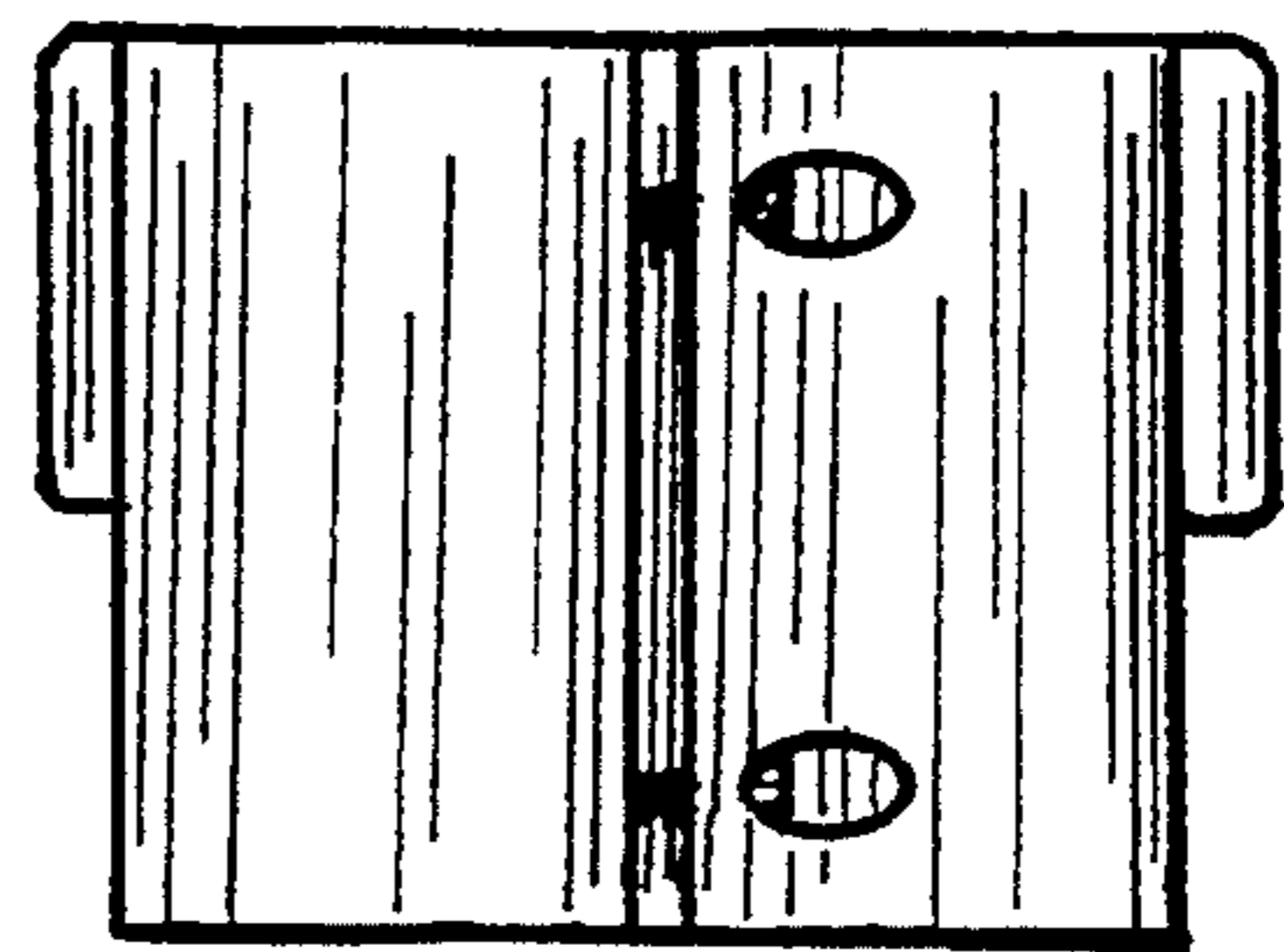

FIG. 7