



US00D354258S

United States Patent [19]

[11] Patent Number: **Des. 354,258**

Ikeda et al.

[45] Date of Patent: **** Jan. 10, 1995**

[54] **VEHICLE**

[75] Inventors: **Yutaka Ikeda**, Rolling Hills Estates;
David Marek, Los Angeles; **Tsuyoshi Nishimura**, Rolling Hills Estates;
Masakazu Udagawa, Rancho Palos Verdes, all of Calif.

[73] Assignee: **Honda Giken Kogyo Kabushiki Kaisha**, Tokyo, Japan

[**] Term: **14 Years**

[21] Appl. No.: **7,000**

[22] Filed: **Apr. 13, 1993**

[52] U.S. Cl. **D12/91**

[58] Field of Search **D12/91; 296/185**

[56] **References Cited**

U.S. PATENT DOCUMENTS

- D. 332,587 1/1993 Halbert et al. D12/91
- D. 338,639 8/1993 Hayashi et al. D12/91

OTHER PUBLICATIONS

Car & Driver, Feb. 1991, pp. 63 & 66, Honda Accord EX Wagon.

Primary Examiner—James M. Gandy
Attorney, Agent, or Firm—Nikaido, Marmelstein, Murray & Oram

[57] **CLAIM**

The ornamental design for a vehicle, as shown and described.

DESCRIPTION

FIG. 1 is a front, left-side, top perspective view of a vehicle showing my new design;
FIG. 2 is a rear, left-side, top perspective view thereof;
FIG. 3 is an enlarged front view thereof;
FIG. 4 is an enlarged rear view thereof;
FIG. 5 is a top view thereof on a reduced scale; and,
FIG. 6 is a left side view thereof on a reduced scale, the right side being the same.

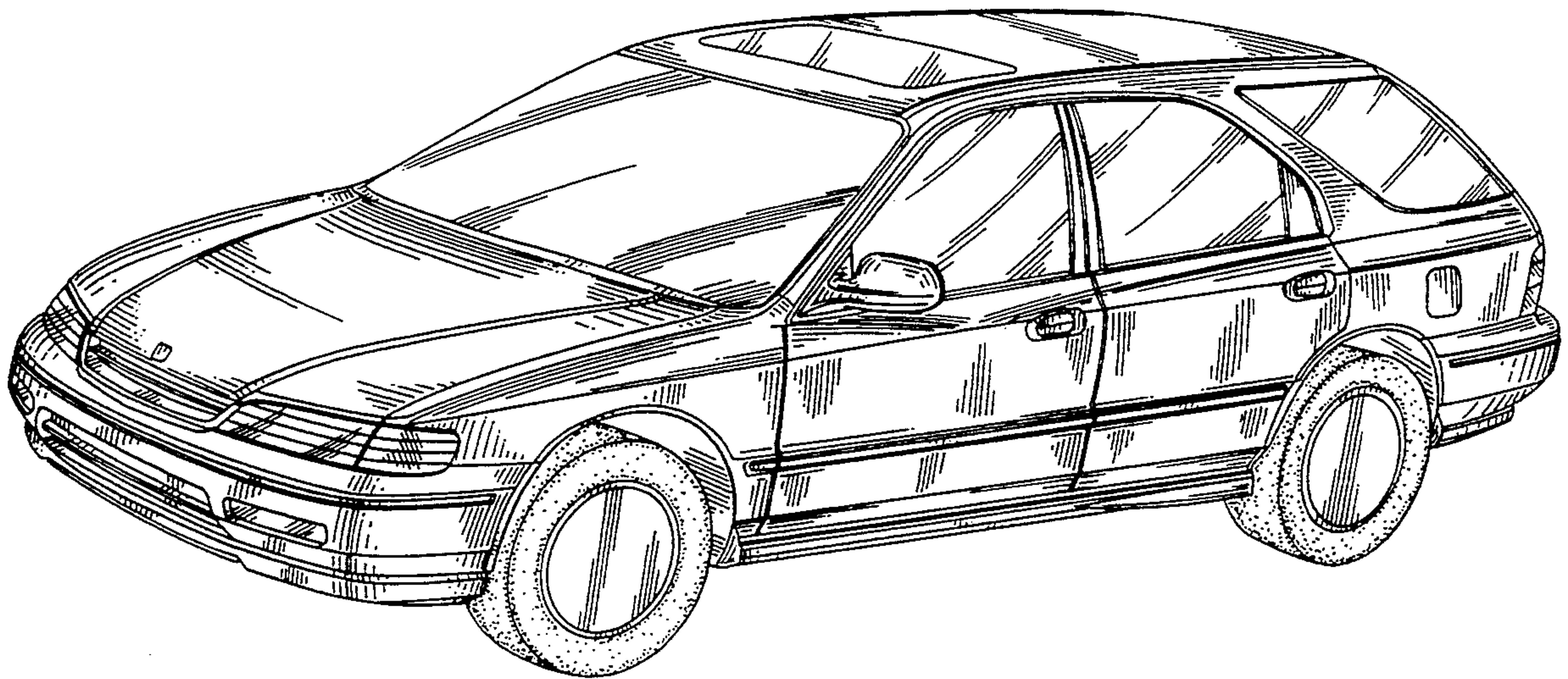

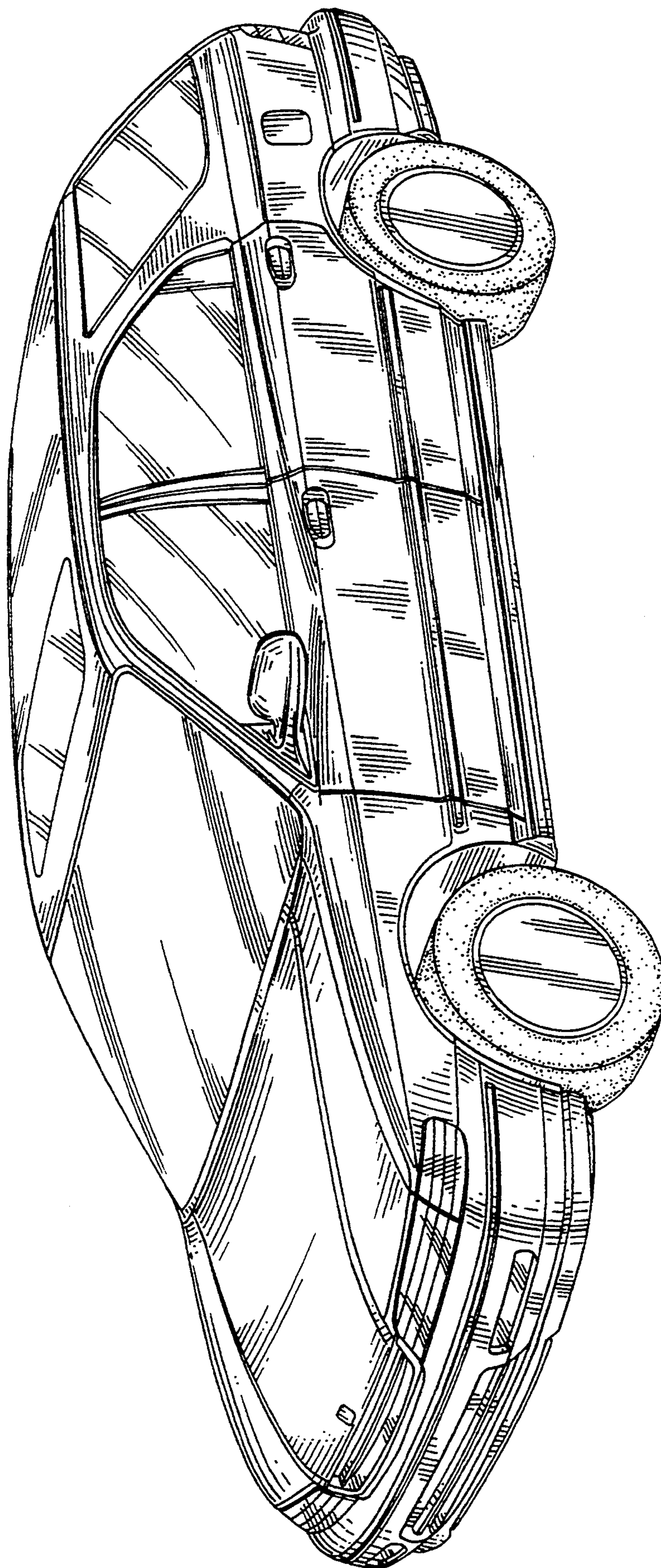

FIG. 1

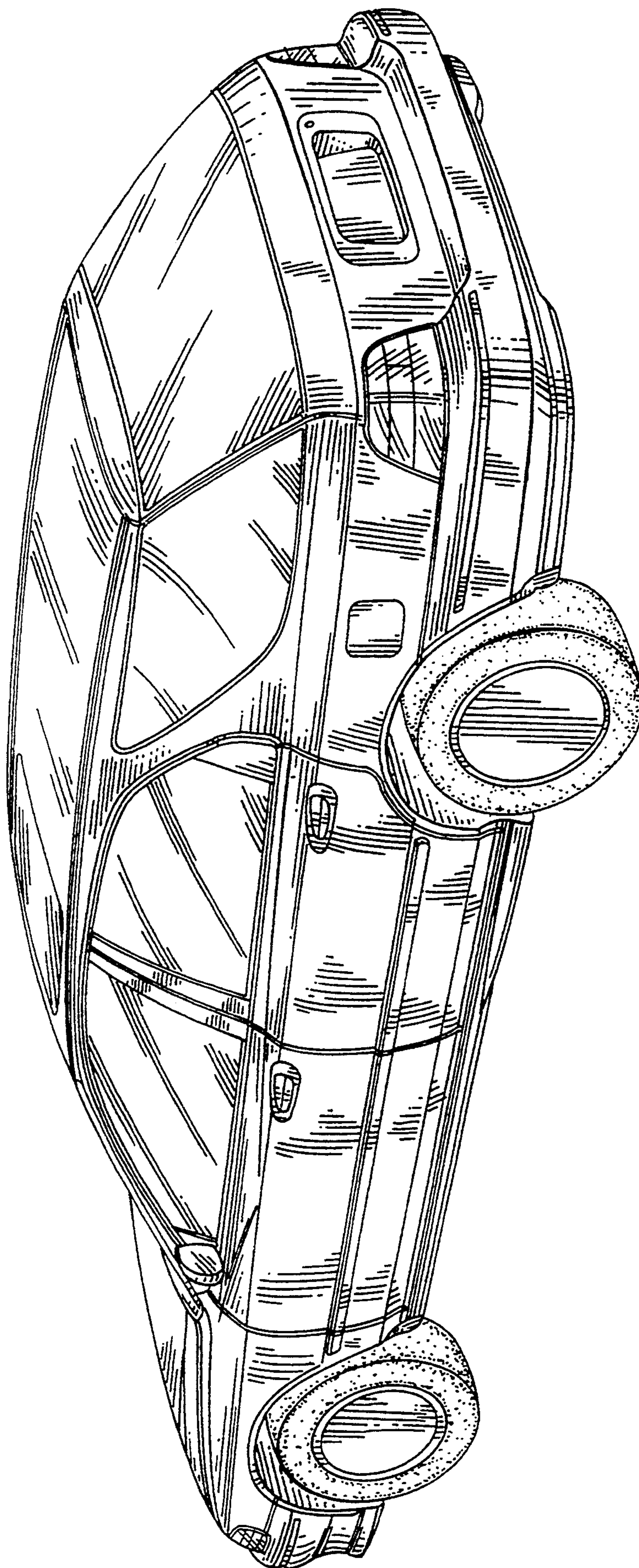

FIG. 2

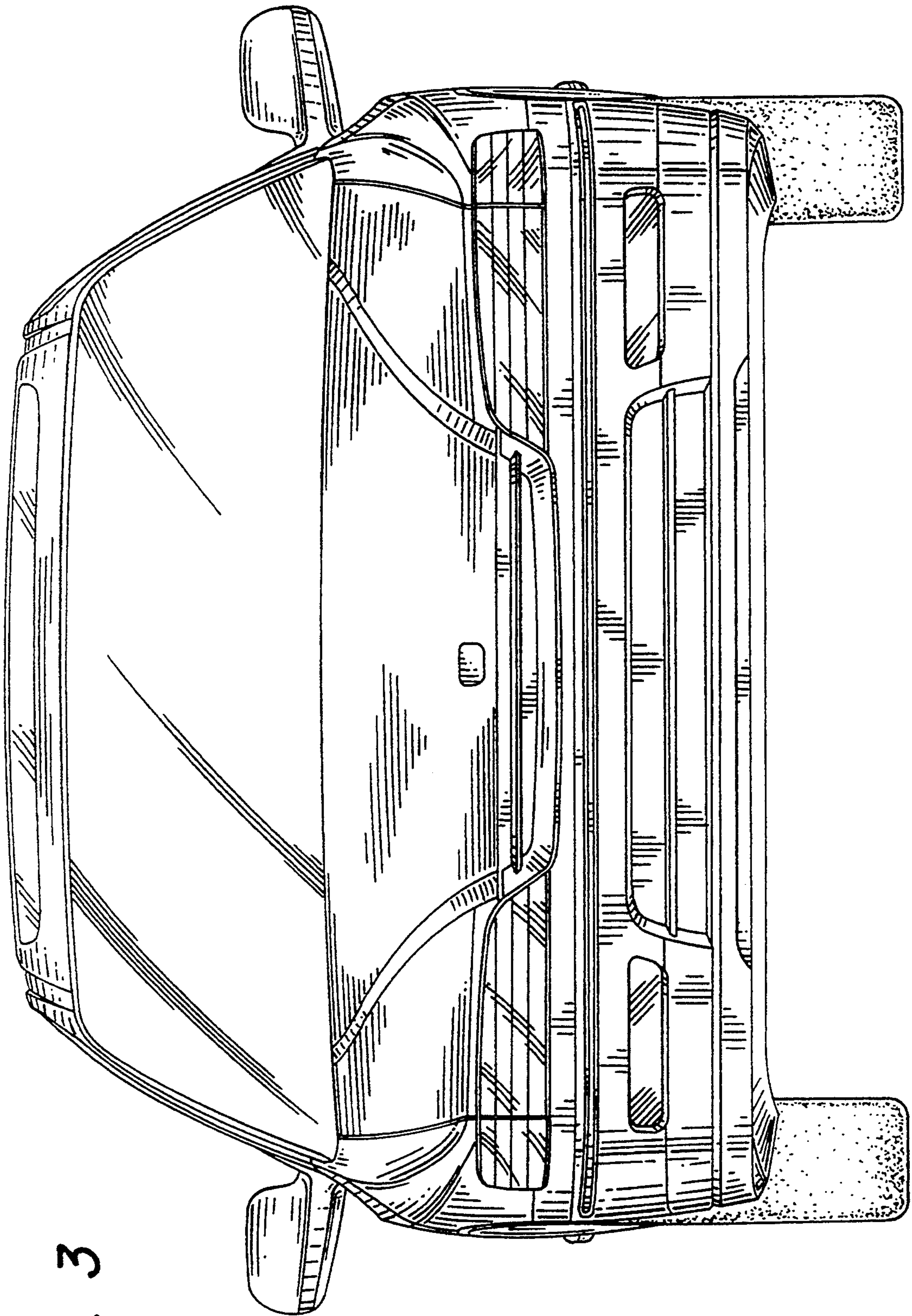

FIG. 3

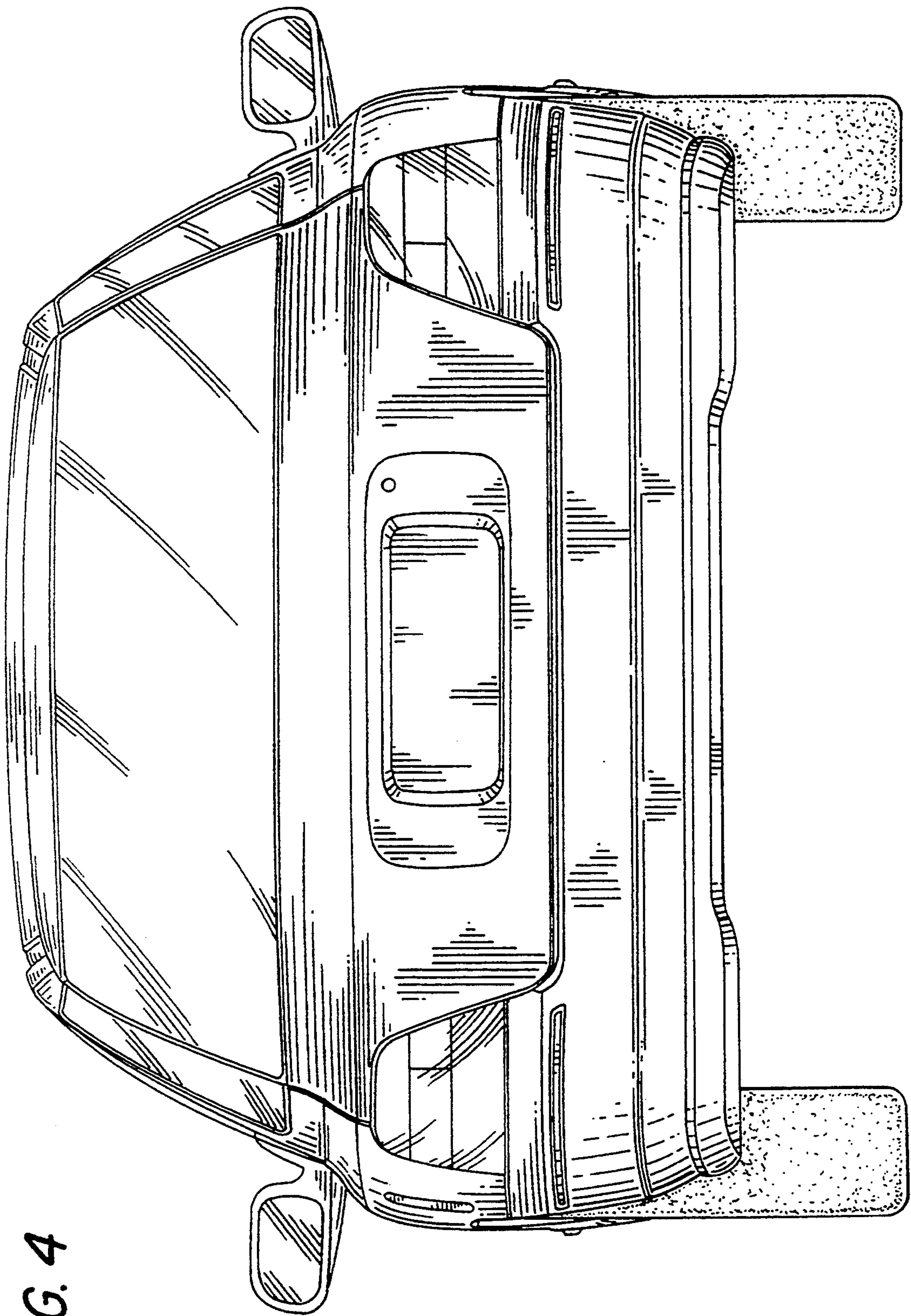

FIG. 4

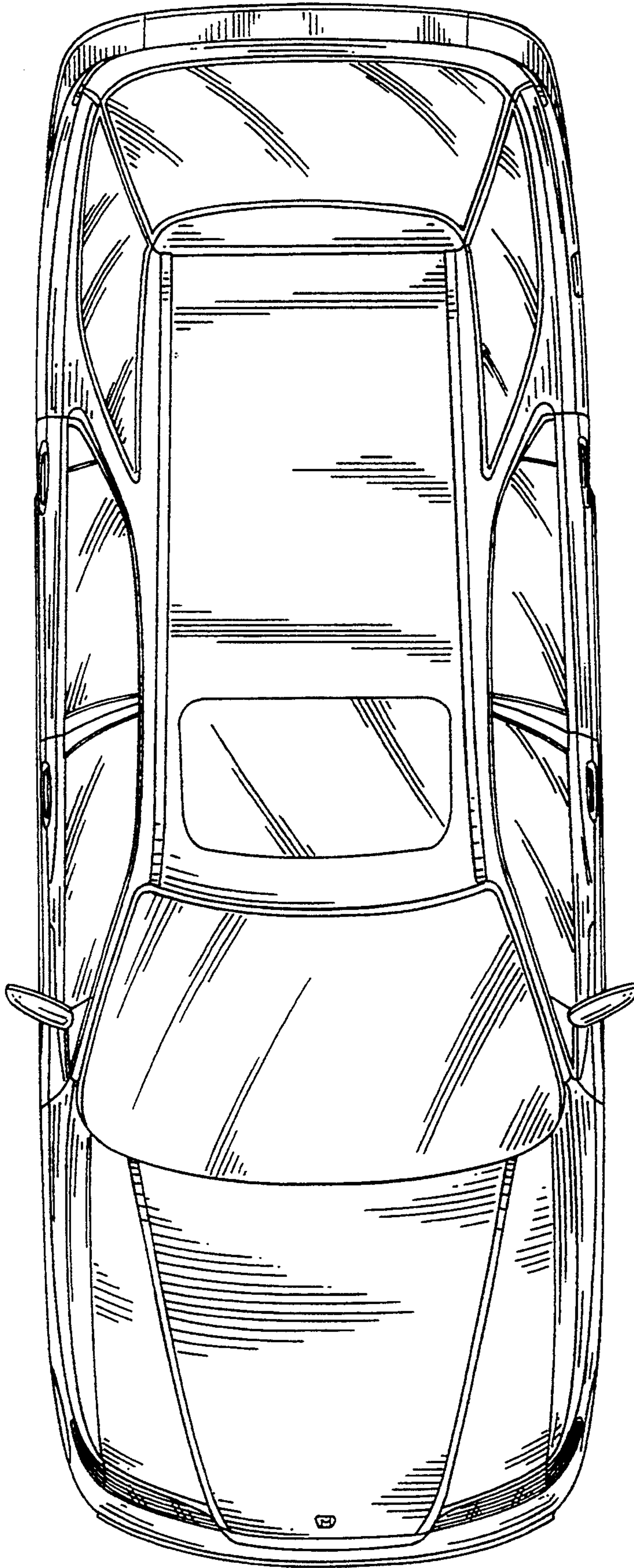

FIG. 5

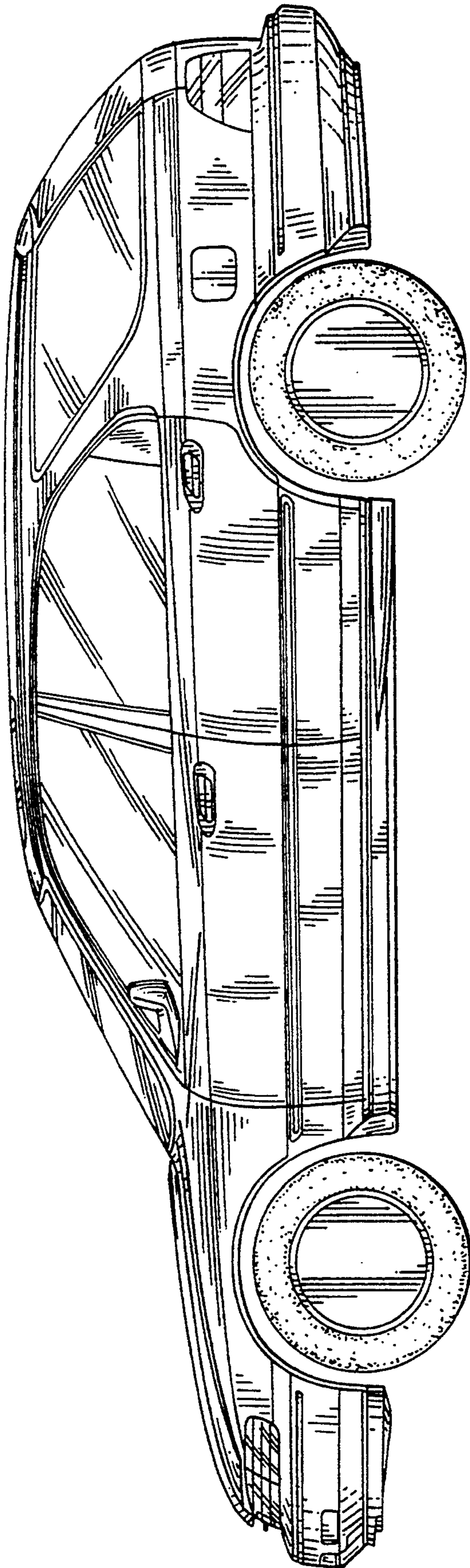

FIG. 6