



US00D354207S

United States Patent [19]

[11] Patent Number: **Des. 354,207**

Dawson

[45] Date of Patent: **** Jan. 10, 1995**

[54] BRAKE ADJUSTER

4,676,346 6/1987 Barberis 188/202

[76] Inventor: **Ronald A. Dawson**, 20264 DuBois, Clinton Township, Macomb County, Mich. 48035

OTHER PUBLICATIONS

Sporty's Tool Shop Catalog; Sep. 1984; p. 40 "Chain Clamp".

[**] Term: **14 Years**

Primary Examiner—Melvin B. Feifer
Assistant Examiner—Mitchell I. Siegel
Attorney, Agent, or Firm—Terry M. Gernstein

[21] Appl. No.: **6,628**

[57] CLAIM

[22] Filed: **Apr. 2, 1993**

The ornamental design for a brake adjuster, as shown and described.

[52] U.S. Cl. **D8/14**

[58] Field of Search D8/14, 22, 21, 14, 23, D8/396, 544, 341; 81/64, 65, 3.43; 24/19, 20 TT, 269

DESCRIPTION

[56] References Cited

U.S. PATENT DOCUMENTS

3,298,258	1/1967	Miyamae	D8/22 X
3,505,914	4/1970	Ockinga	D8/22 X
4,257,288	3/1981	Bianco	81/64 X
4,441,591	4/1984	Severinson .	
4,544,047	10/1985	Clemmons .	

FIG. 1 is a front, top and side perspective view of the brake adjuster showing my new design; FIG. 2 is a front elevational view thereof; FIG. 3 is a rear elevational view thereof; FIG. 4 is a left end elevational view thereof; FIG. 5 is a right end elevational view thereof; FIG. 6 is a top plan view thereof; and, FIG. 7 is a bottom plan view thereof.

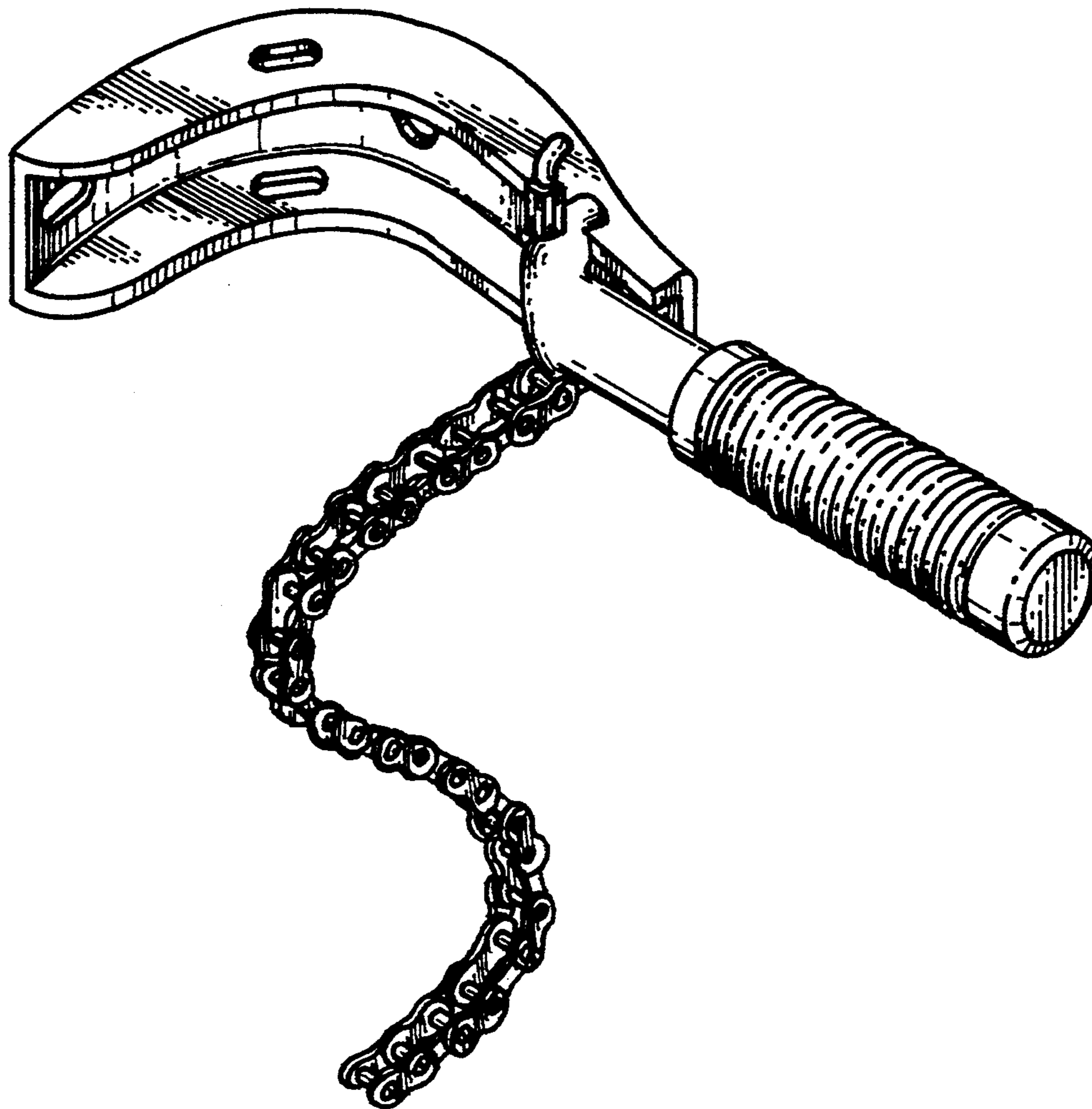

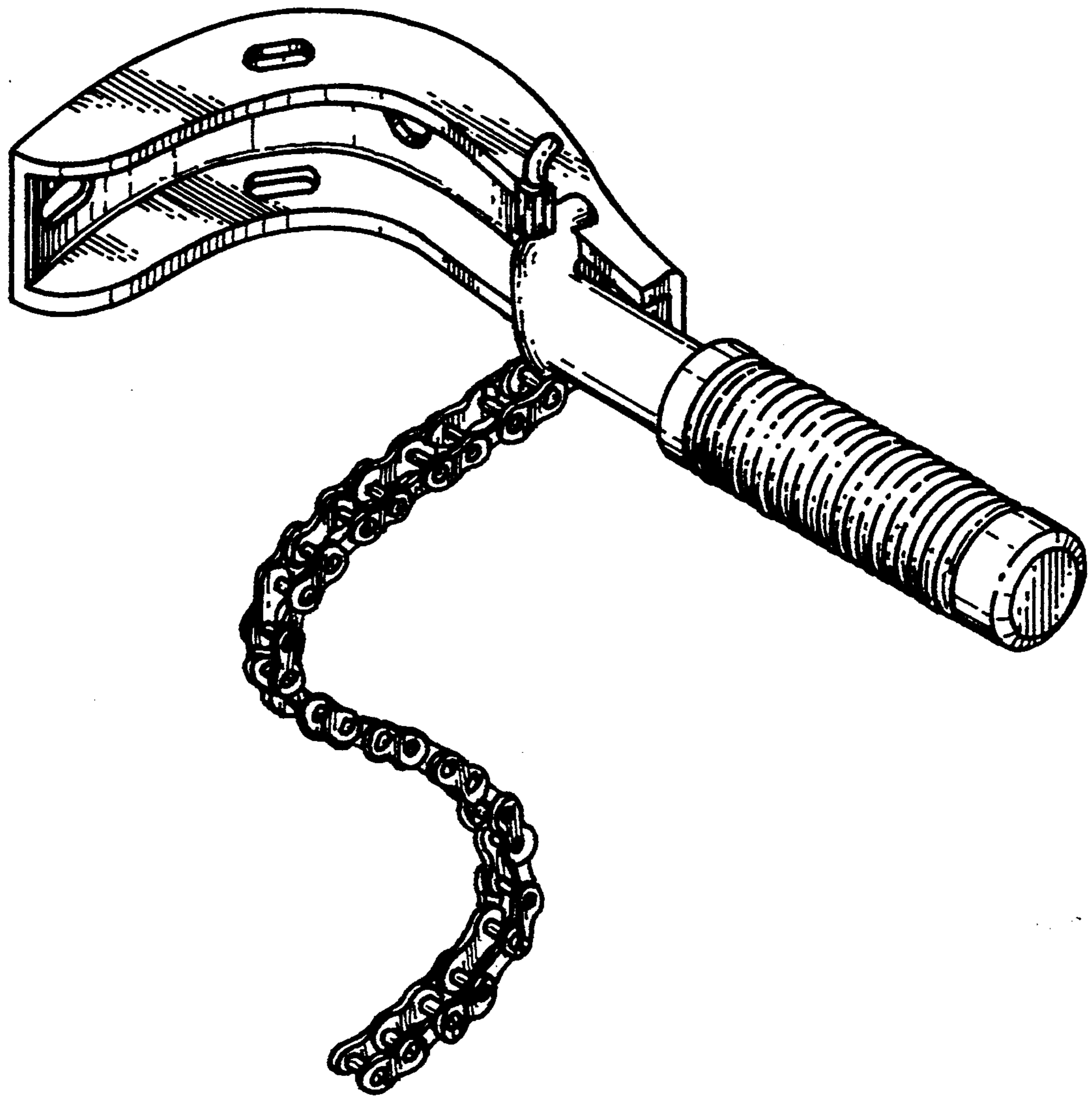

FIG. 1

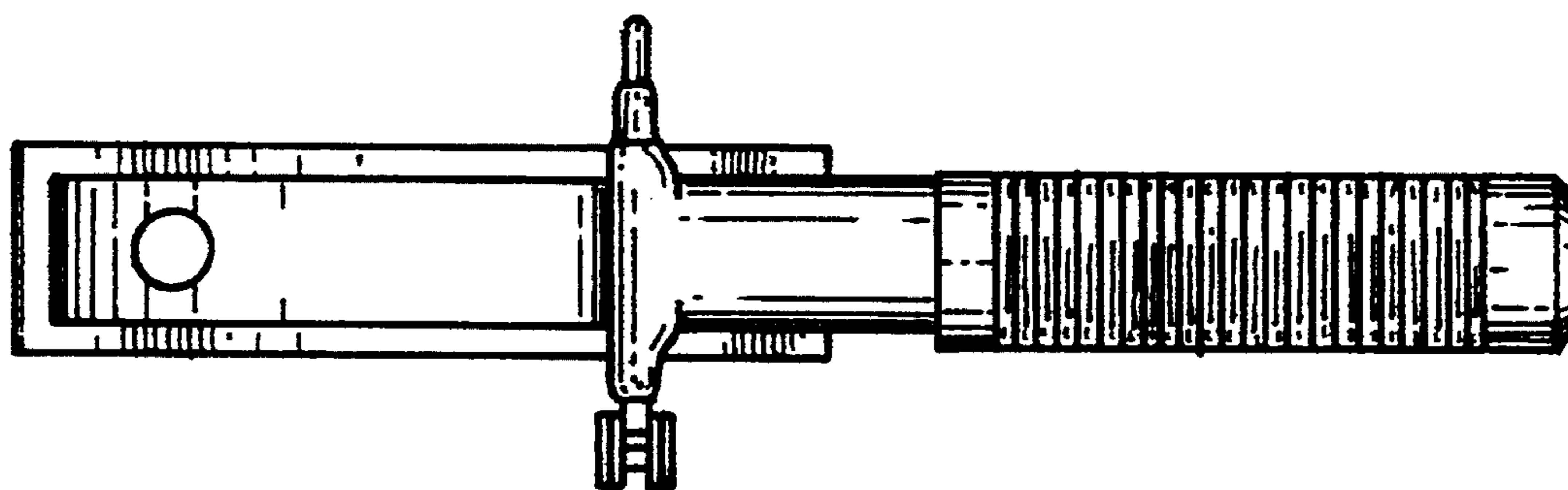

FIG. 2

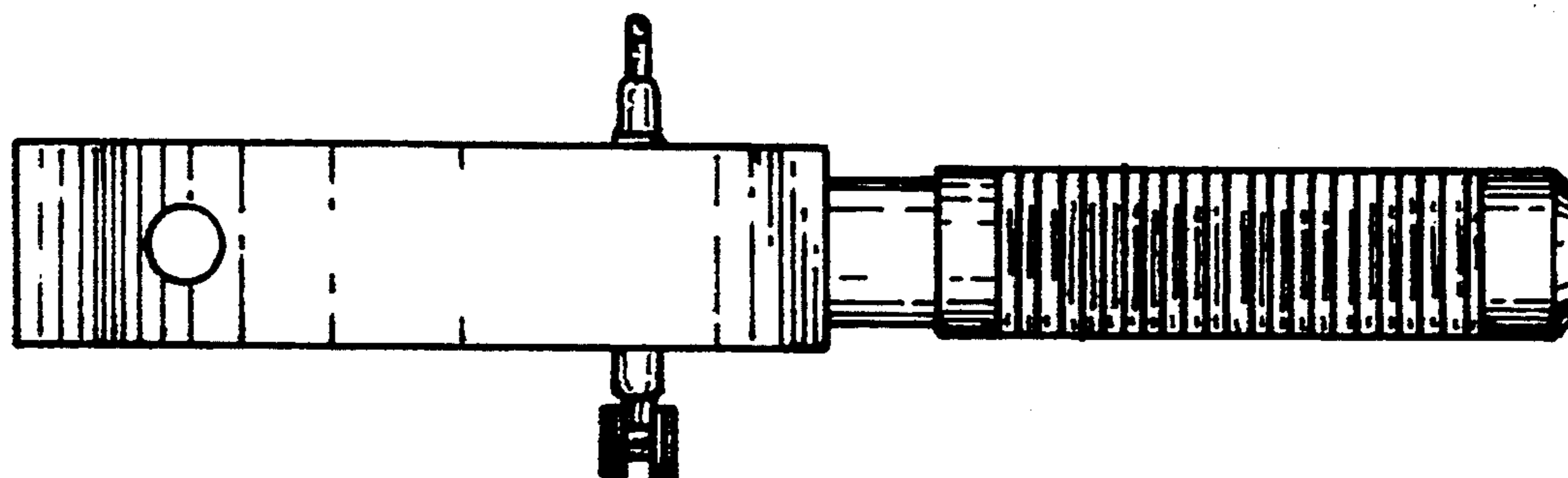

FIG. 3

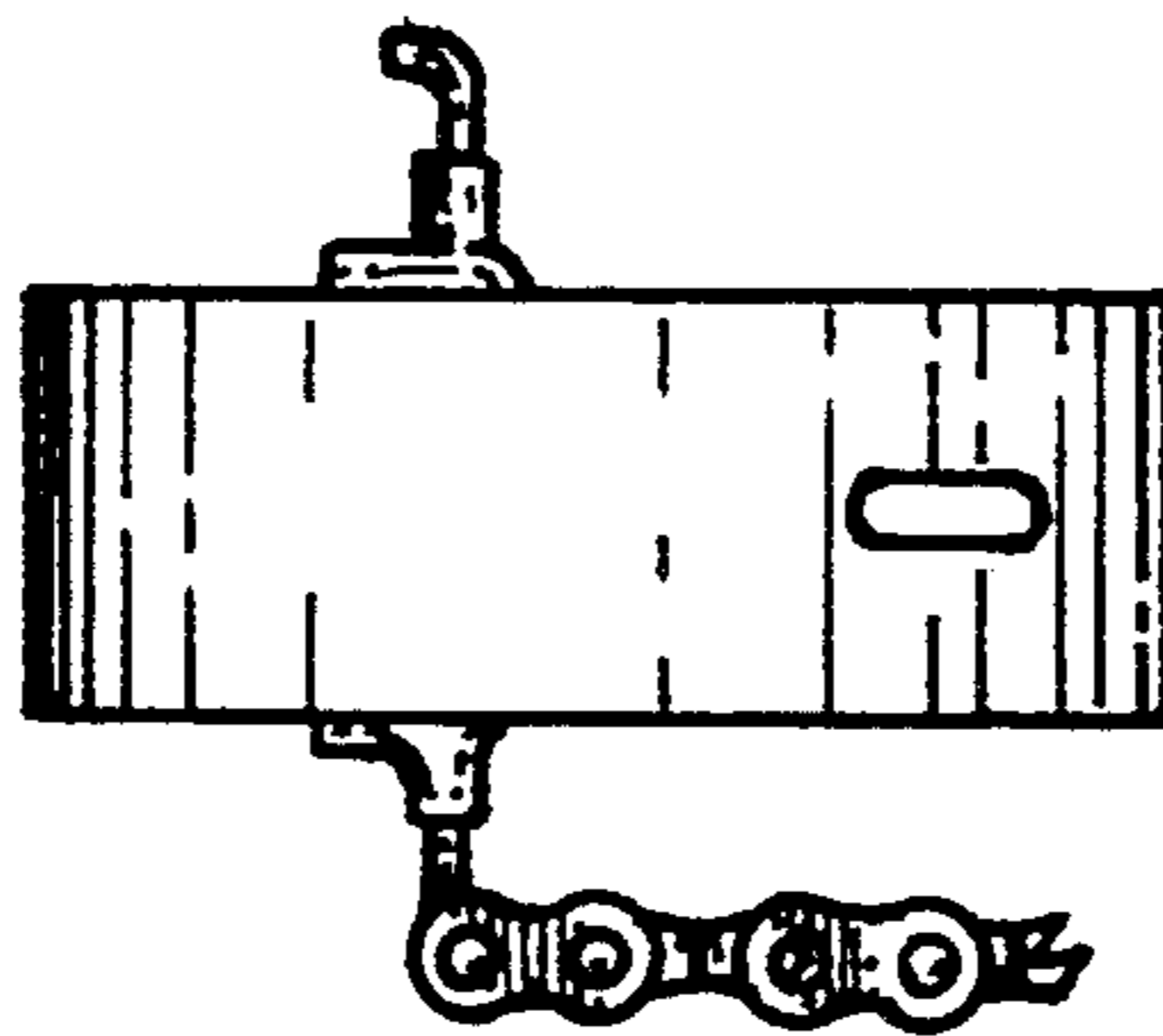

FIG. 4

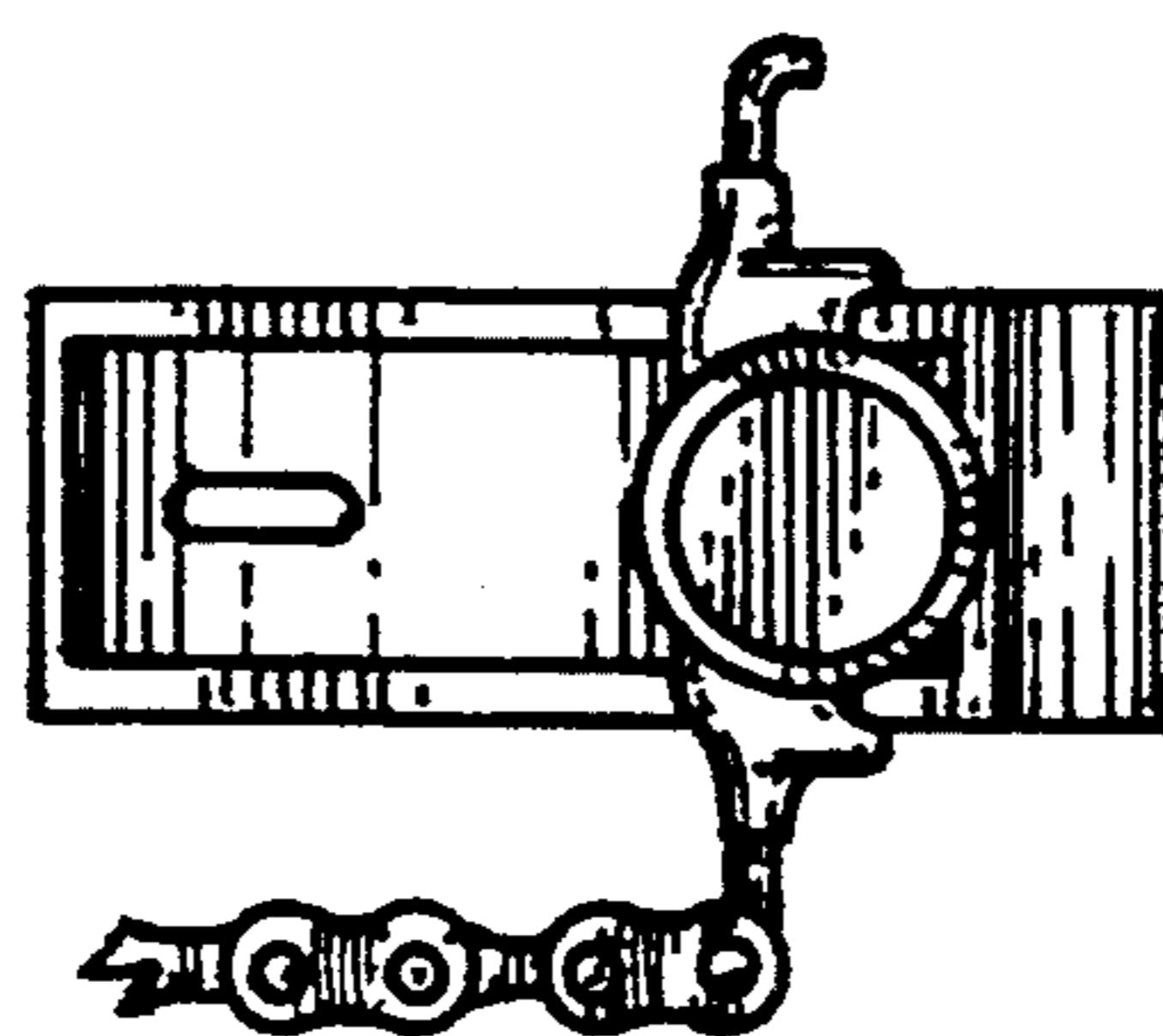

FIG. 5

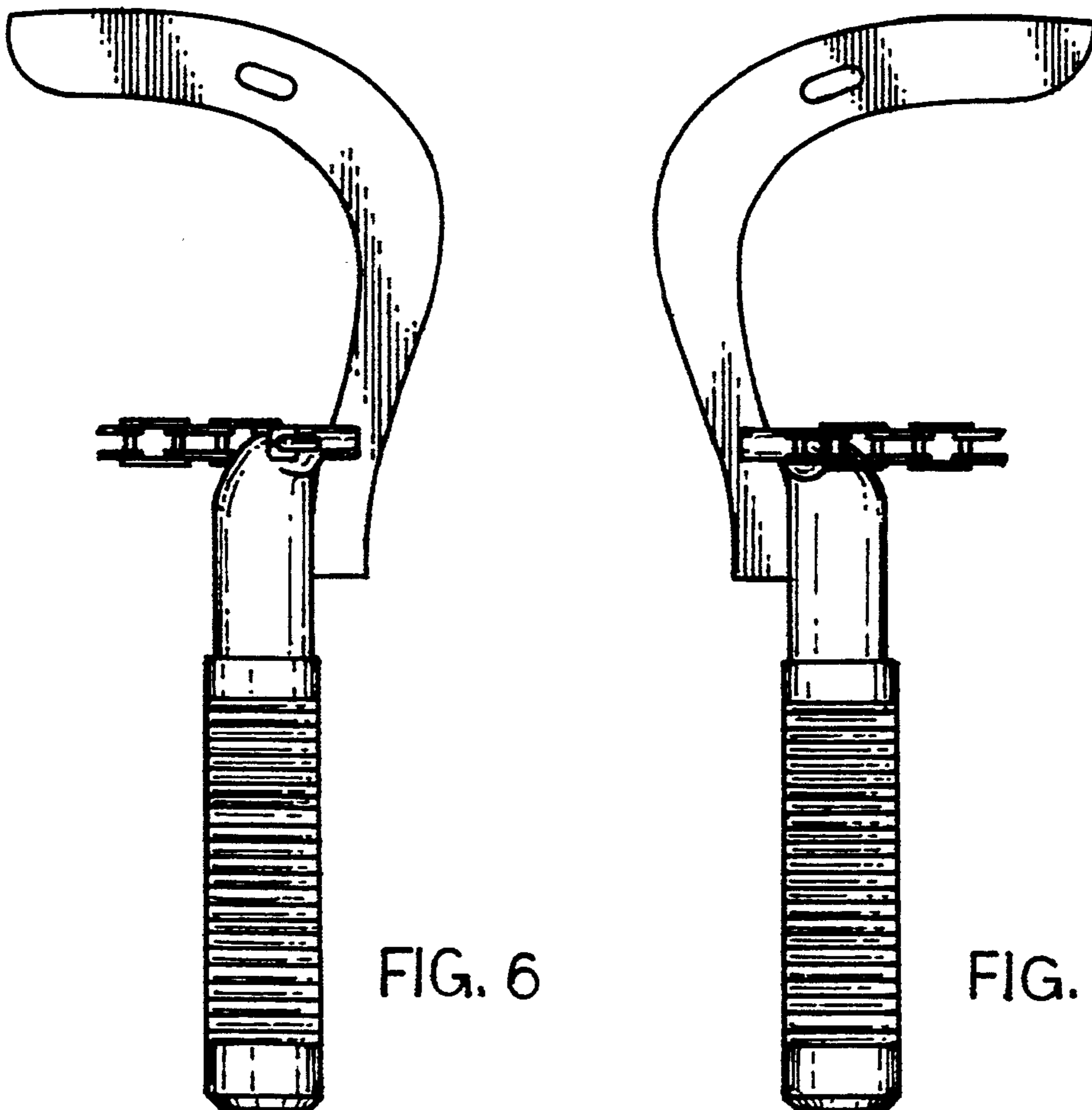

FIG. 6

FIG. 7