



US00D354166S

# United States Patent [19]

[11] Patent Number: **Des. 354,166**

Lin

[45] Date of Patent: **\*\* Jan. 10, 1995**

[54] **SUITCASE**

D. 336,365 6/1993 Huang ..... D3/279

[76] Inventor: **Yi-Cheng Lin**, No. 7, Lane 37,  
Wen-Hua St., Fengyuan City,  
Taiwan, Prov. of China

*Primary Examiner*—Bernard Ansher  
*Assistant Examiner*—Dominic Simone  
*Attorney, Agent, or Firm*—Oblon, Spivak, McClelland,  
Maier, & Neustadt

[\*\*] Term: **14 Years**

[57] **CLAIM**

[21] Appl. No.: **10,254**

The ornamental design for suitcase, as shown and described.

[22] Filed: **Jul. 2, 1993**

[52] U.S. Cl. .... **D3/276; D3/279;  
D3/281; D3/289**

**DESCRIPTION**

[58] **Field of Search** ..... **D3/273, 276, 279, 281,  
D3/289; 150/111, 127, 128; 190/18 A, 100,  
109, 112, 115, 116, 124, 126, 900-903**

FIG. 1 is a perspective view of suitcase showing my new design;  
FIG. 2 is a front elevational view thereof;  
FIG. 3 is a rear elevational view thereof;  
FIG. 4 is a left side elevational view thereof;  
FIG. 5 is a right side elevational view thereof;  
FIG. 6 is a top plan view thereof;  
FIG. 7 is a bottom plan view thereof; and,  
FIG. 8 is a front perspective view thereof, the handle and luggage support extended, and the briefcase shown in broken lines for illustrative purposes only.

[56] **References Cited**

**U.S. PATENT DOCUMENTS**

- D. 177,266 3/1956 Levitan ..... D3/289
- D. 276,052 10/1984 Wedel et al. .... D3/279 X
- D. 287,779 1/1987 Slany ..... D3/279 X
- D. 292,749 11/1987 Allen ..... D3/279 X

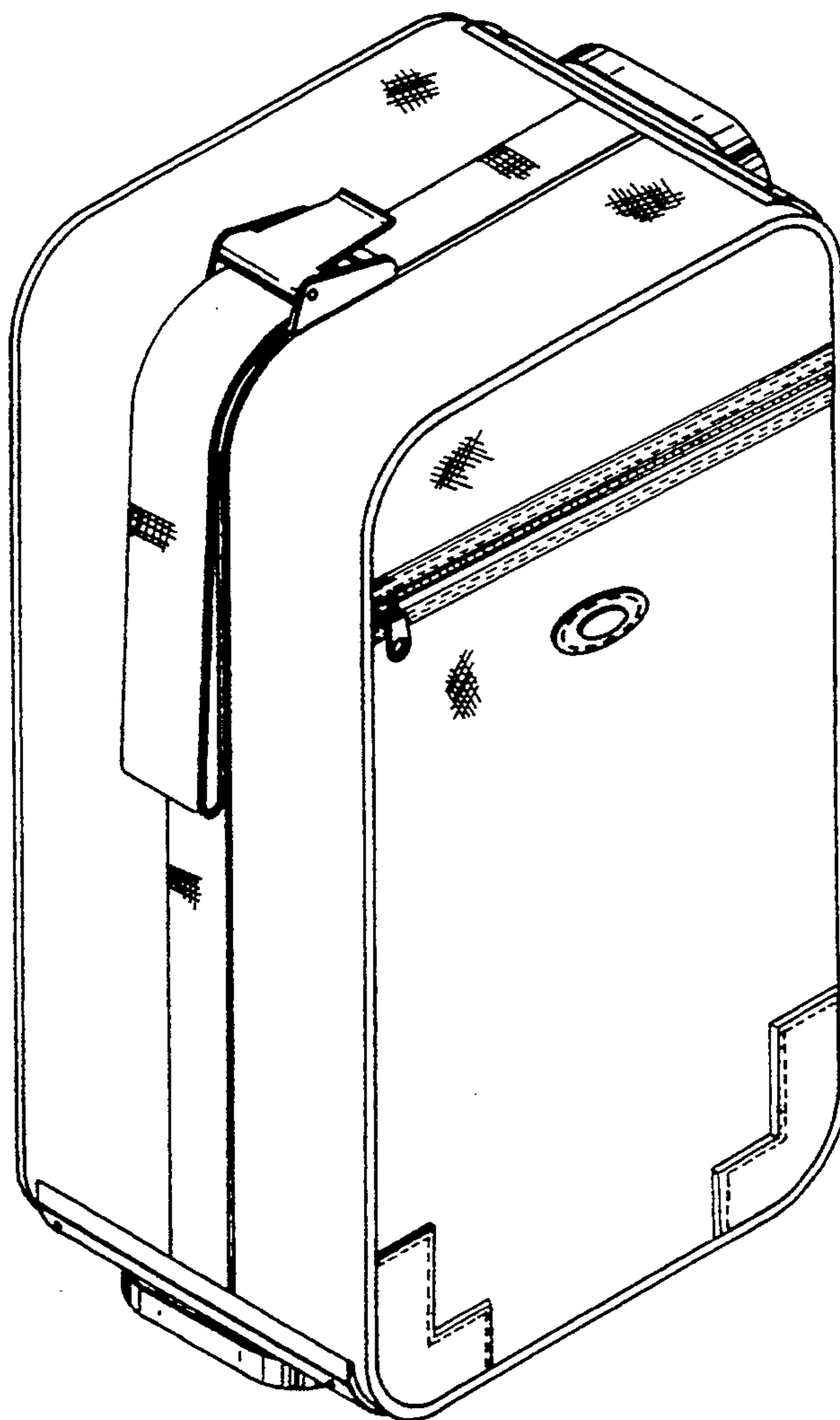

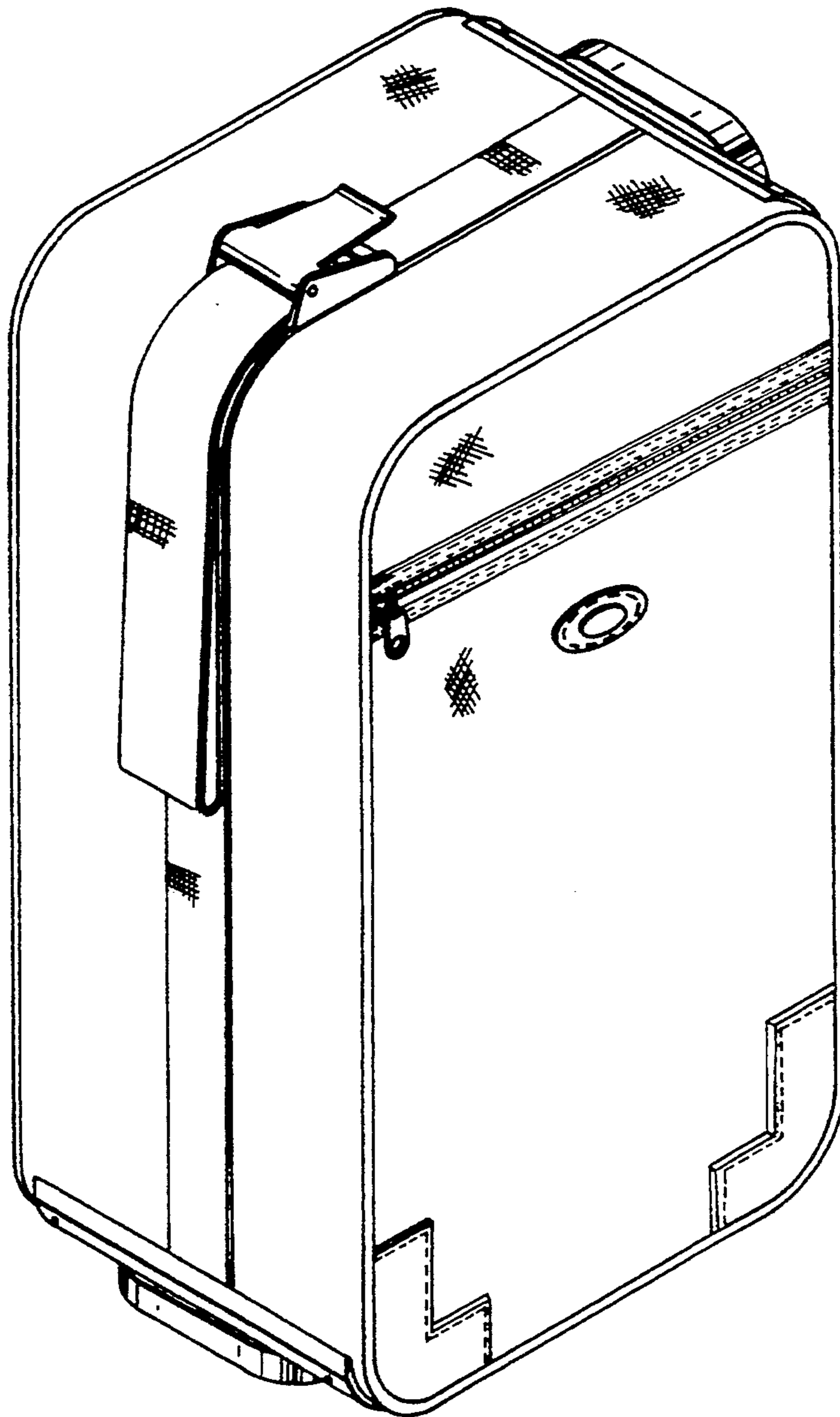

FIG. 1

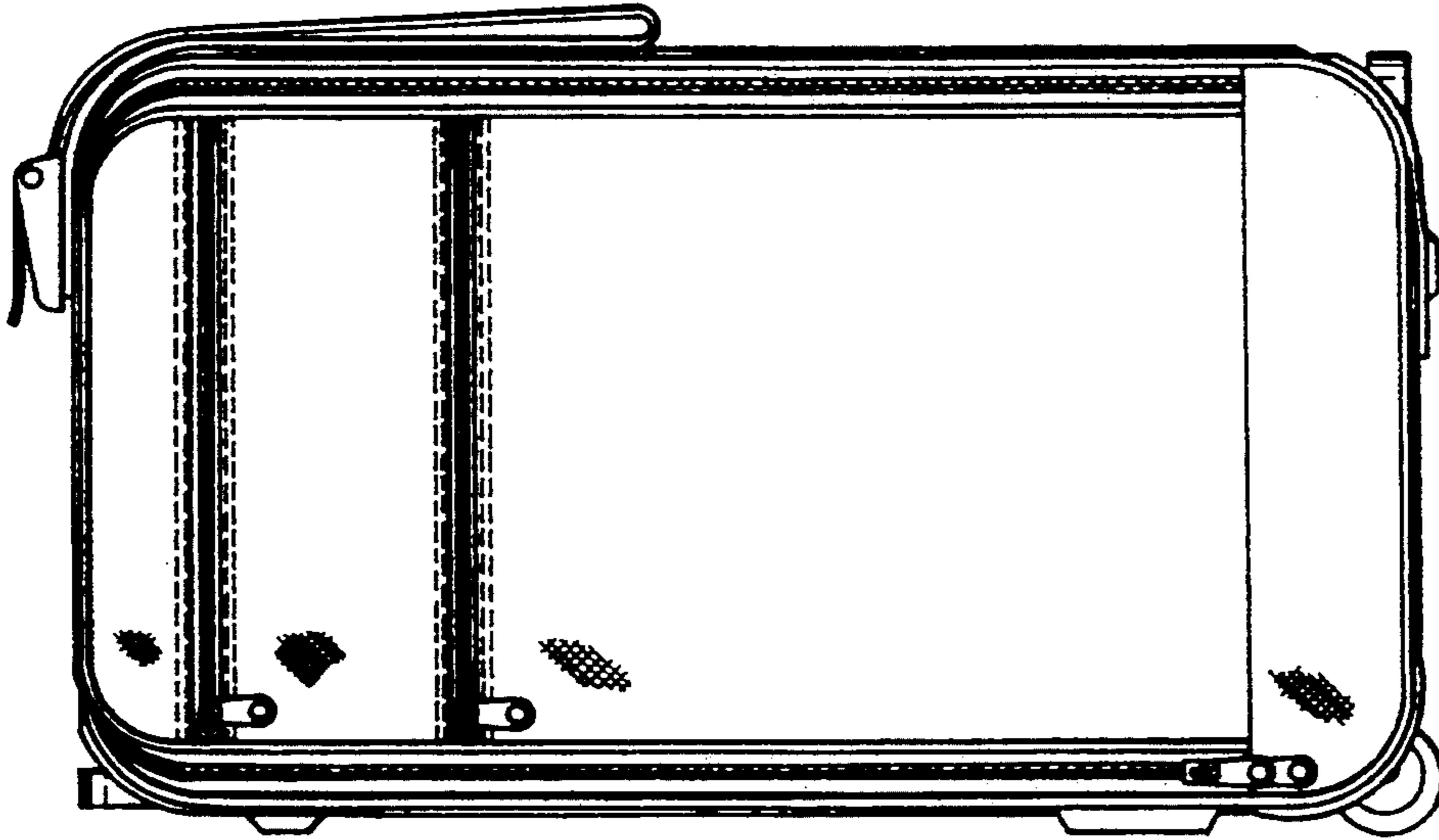

FIG. 3

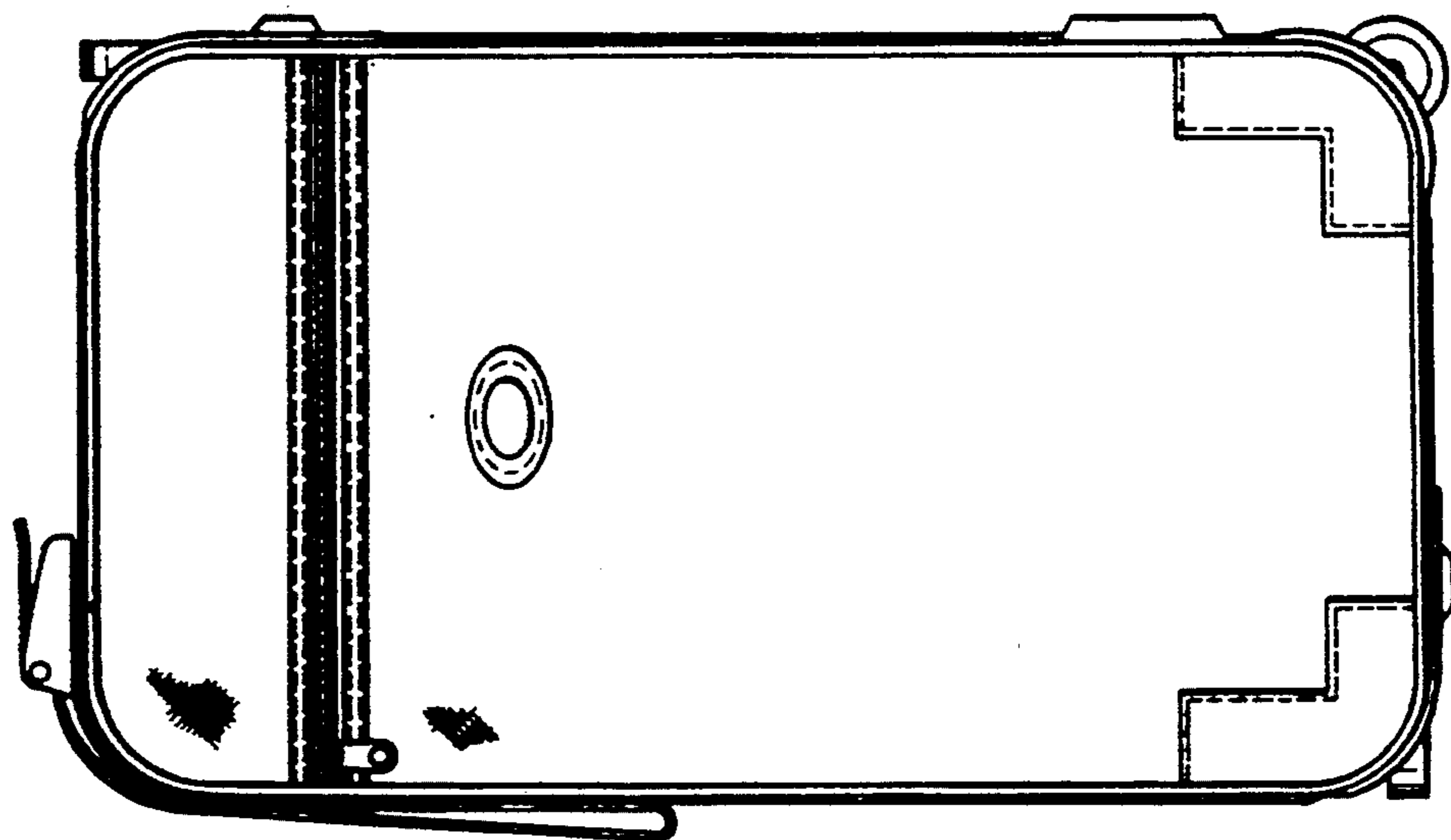

FIG. 2

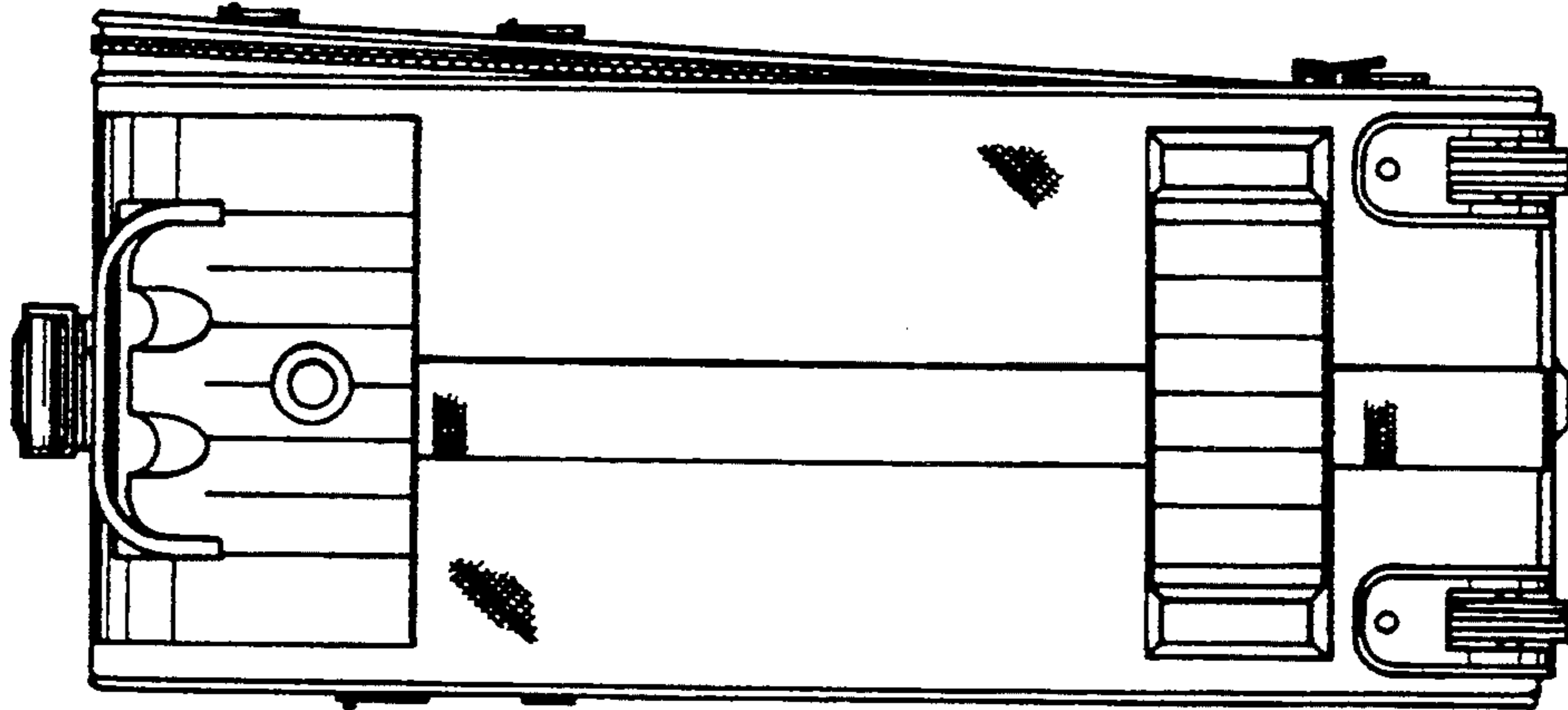

FIG. 5

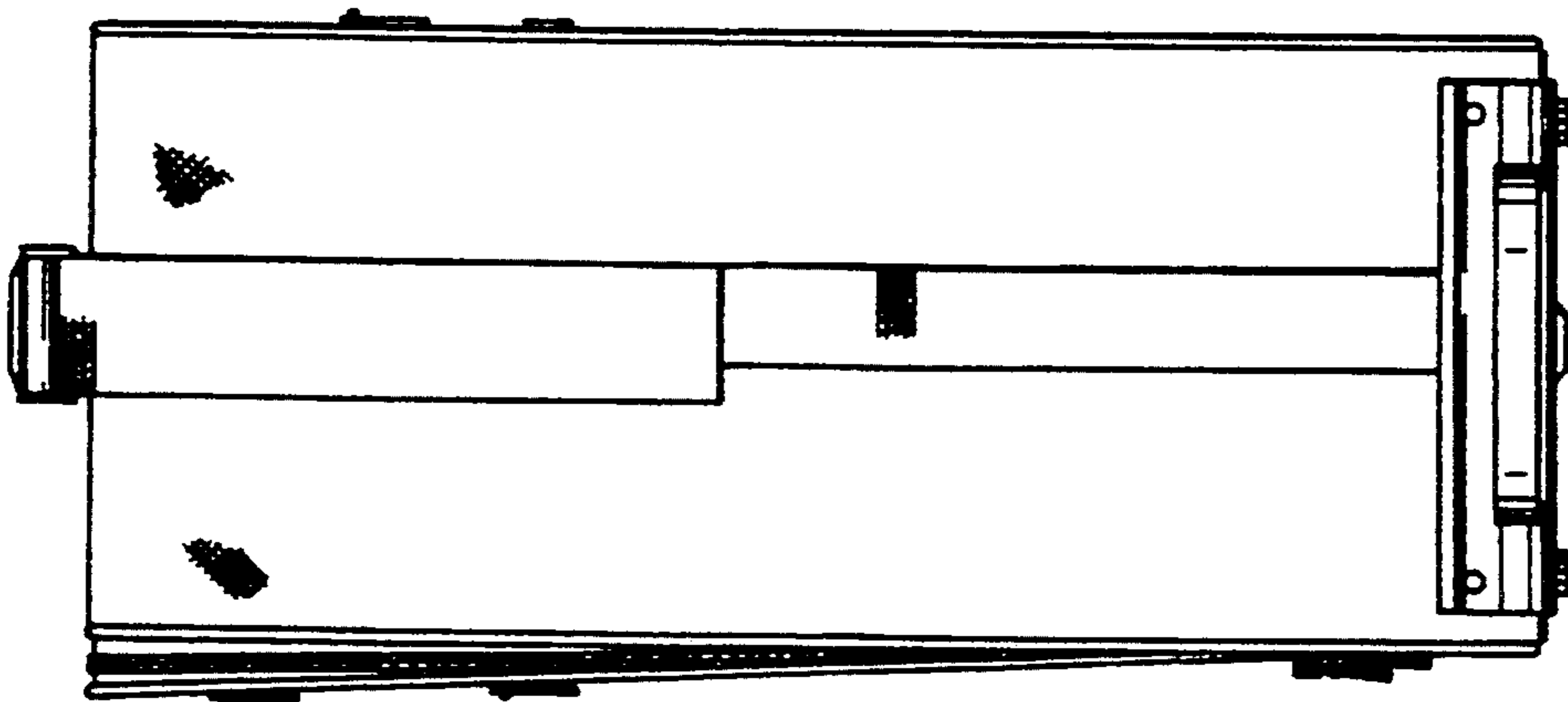

FIG. 4

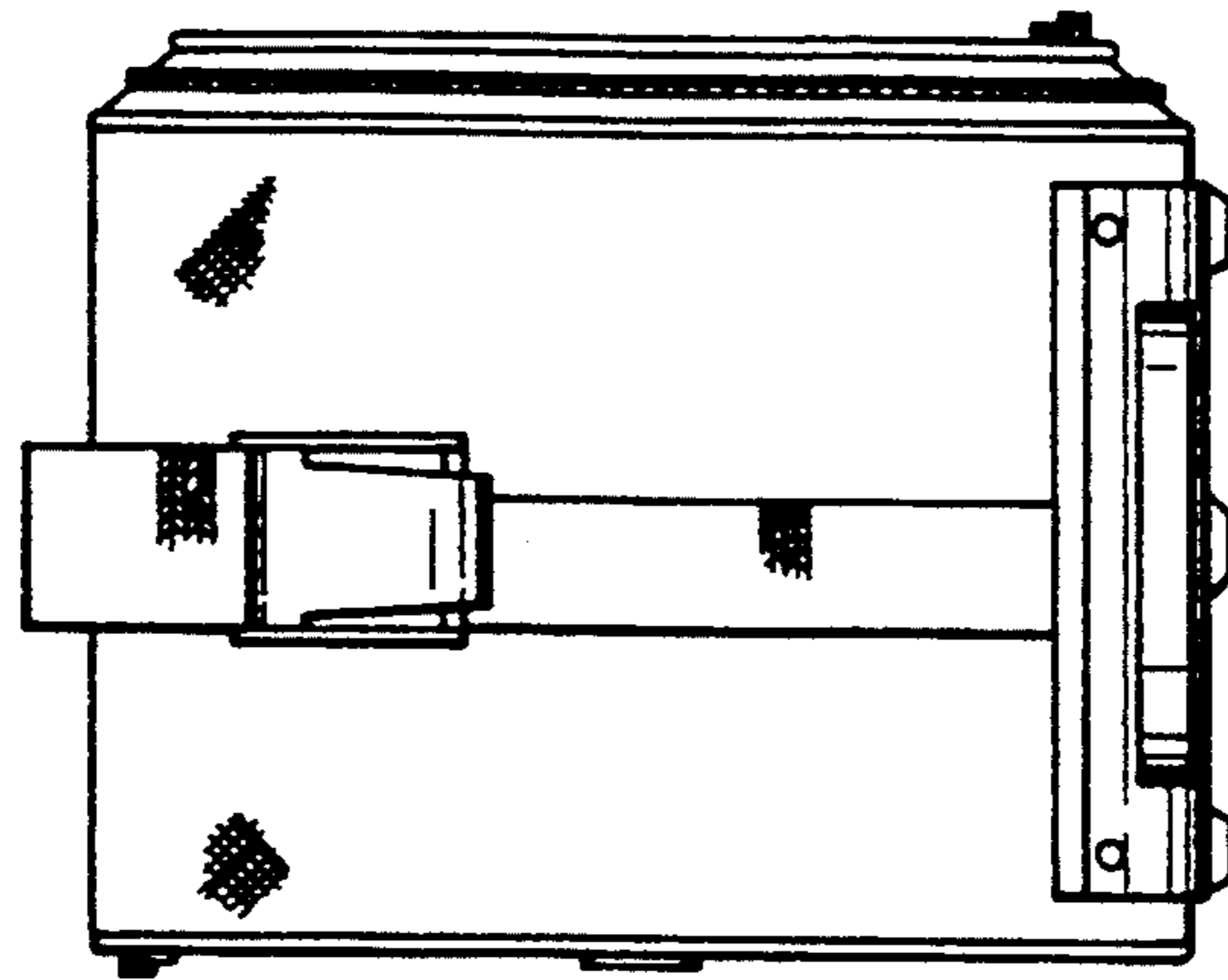

FIG. 6

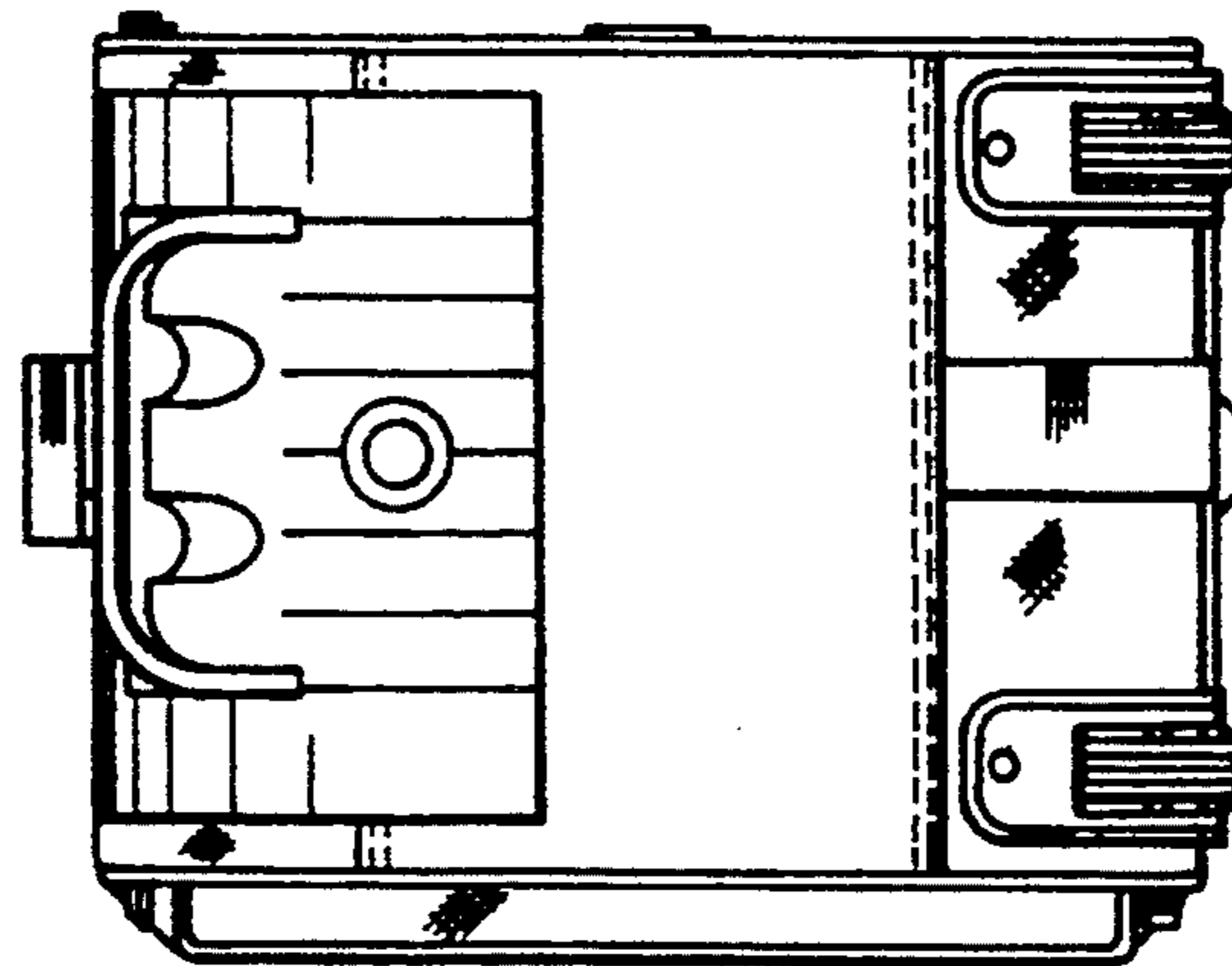

FIG. 7

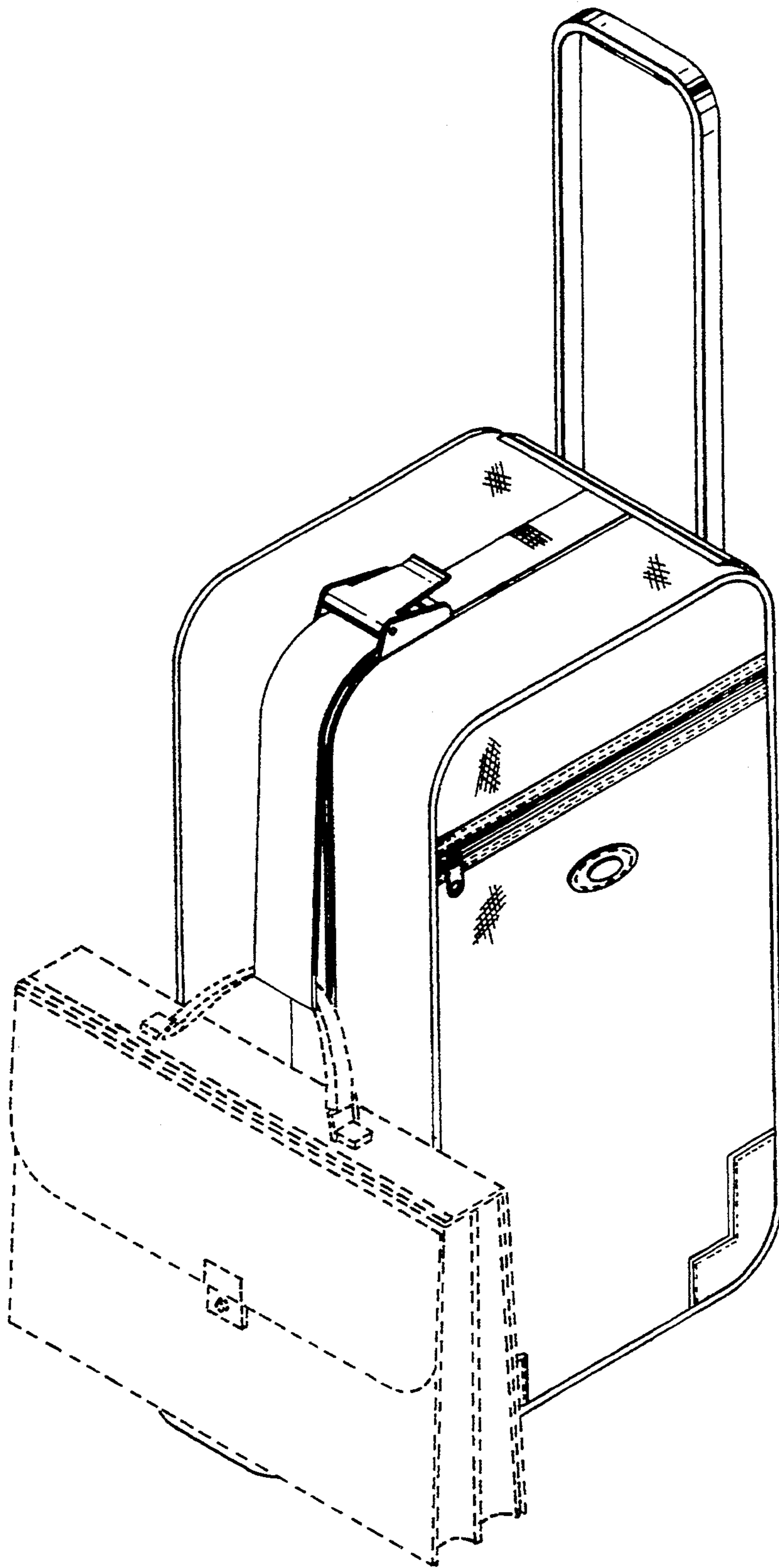

FIG. 8