



US00D354143S

United States Patent [19]

Floyd, Jr.

[11] Patent Number: **Des. 354,143**

[45] Date of Patent: **** Jan. 3, 1995**

[54] HUNTER'S TREE STAND

[76] Inventor: **Claude A. Floyd, Jr., Rte. 2, Box 405-2, Norwood, N.C. 28128**

[**] Term: **14 Years**

[21] Appl. No.: **4,150**

[22] Filed: **Jan. 27, 1993**

[52] U.S. Cl. **D25/62**

[58] Field of Search **D25/62; 182/115-116, 182/191, 182, 187**

[56] References Cited

U.S. PATENT DOCUMENTS

D. 270,951	10/1983	Cryar	D25/62
D. 275,235	8/1984	Warren et al.	D25/62
4,321,983	3/1982	Nelson	182/136
4,452,338	6/1984	Untz	182/187
4,953,662	9/1990	Porter	182/187
5,090,505	2/1992	Amacker	182/187
5,103,935	4/1992	Amacker	182/187

OTHER PUBLICATIONS

Autumn, 1990 "The Sportsman's Guide" advertisement. Photocopy of cover and p. 78.

Primary Examiner—A. Hugo Word

Assistant Examiner—Doris Clark

Attorney, Agent, or Firm—Olive & Olive

[57] CLAIM

The ornamental design for a hunter's tree stand, as shown and described.

DESCRIPTION

FIG. 1 is a perspective view of the hunter's tree stand of the invention the broken lines showing a tree are for illustrative purposes only, and form no part of the claimed design;

FIG. 2 is a right side elevation view thereof;

FIG. 3 is a front elevation view of the upper seat portion of the invention;

FIG. 4 is a rear elevation view of the upper seat portion of the invention;

FIG. 5 is a top plan view of the upper seat portion of the invention;

FIG. 6 is a bottom plan view of the upper seat portion of the invention;

FIG. 7 is a top plan view of the lower foot portion of the invention;

FIG. 8 is a bottom plan view of the lower foot portion of the invention;

FIG. 9 is a front elevation view of the lower foot portion of the invention;

FIG. 10 is a rear elevation view of the lower foot portion of the invention;

FIG. 11 is a right side elevation view with the seat folded down; and,

FIG. 12 is a top plan view with the seat folded down.

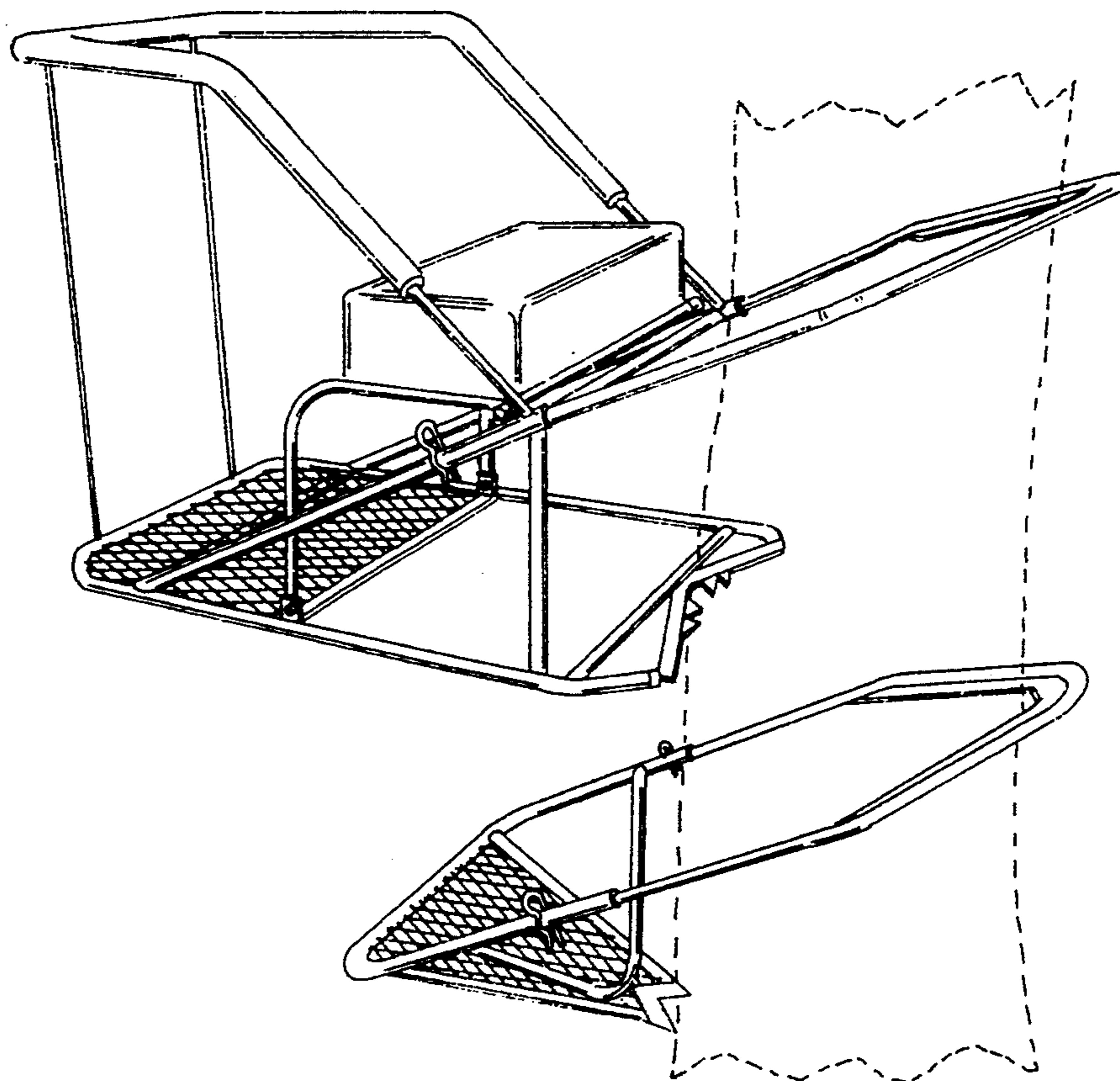

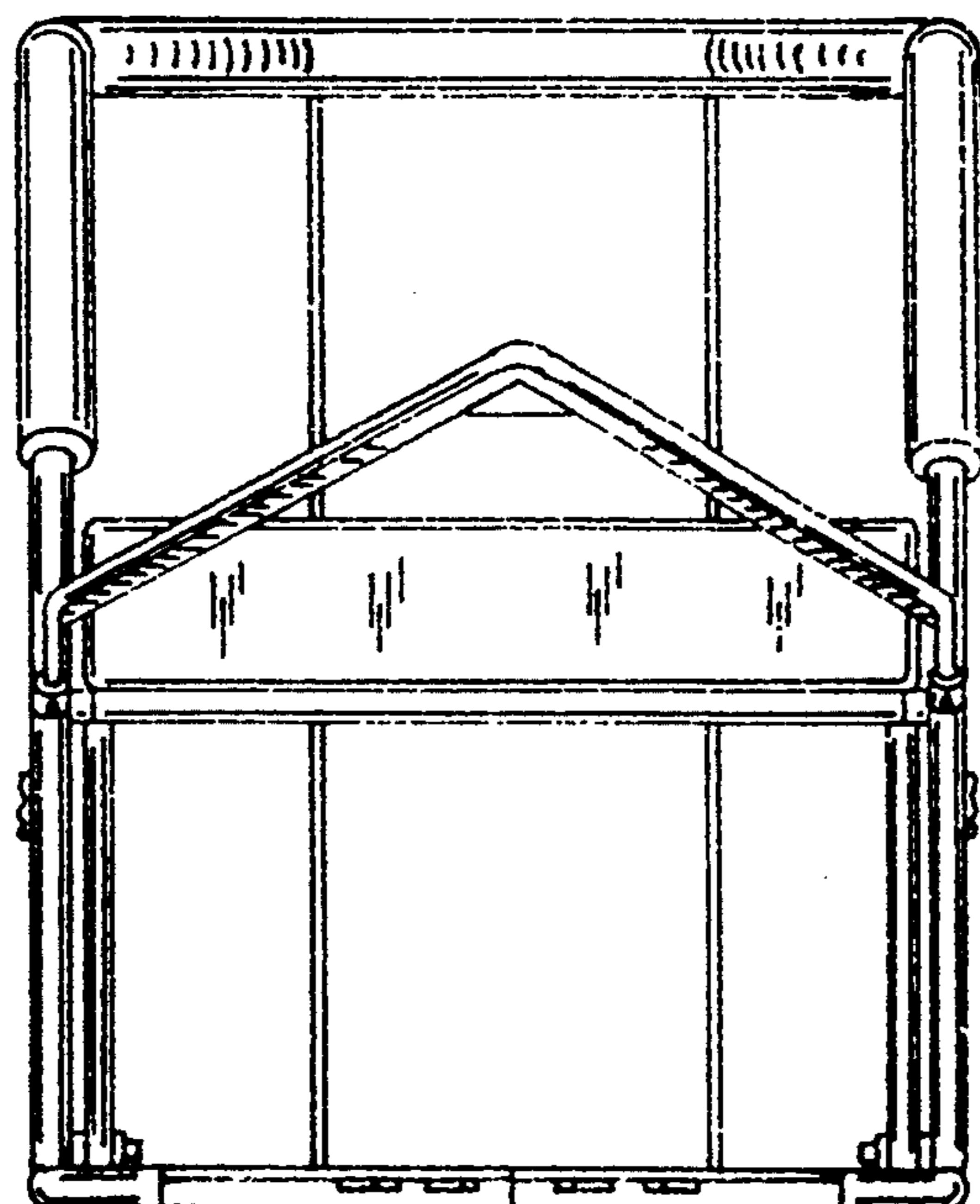
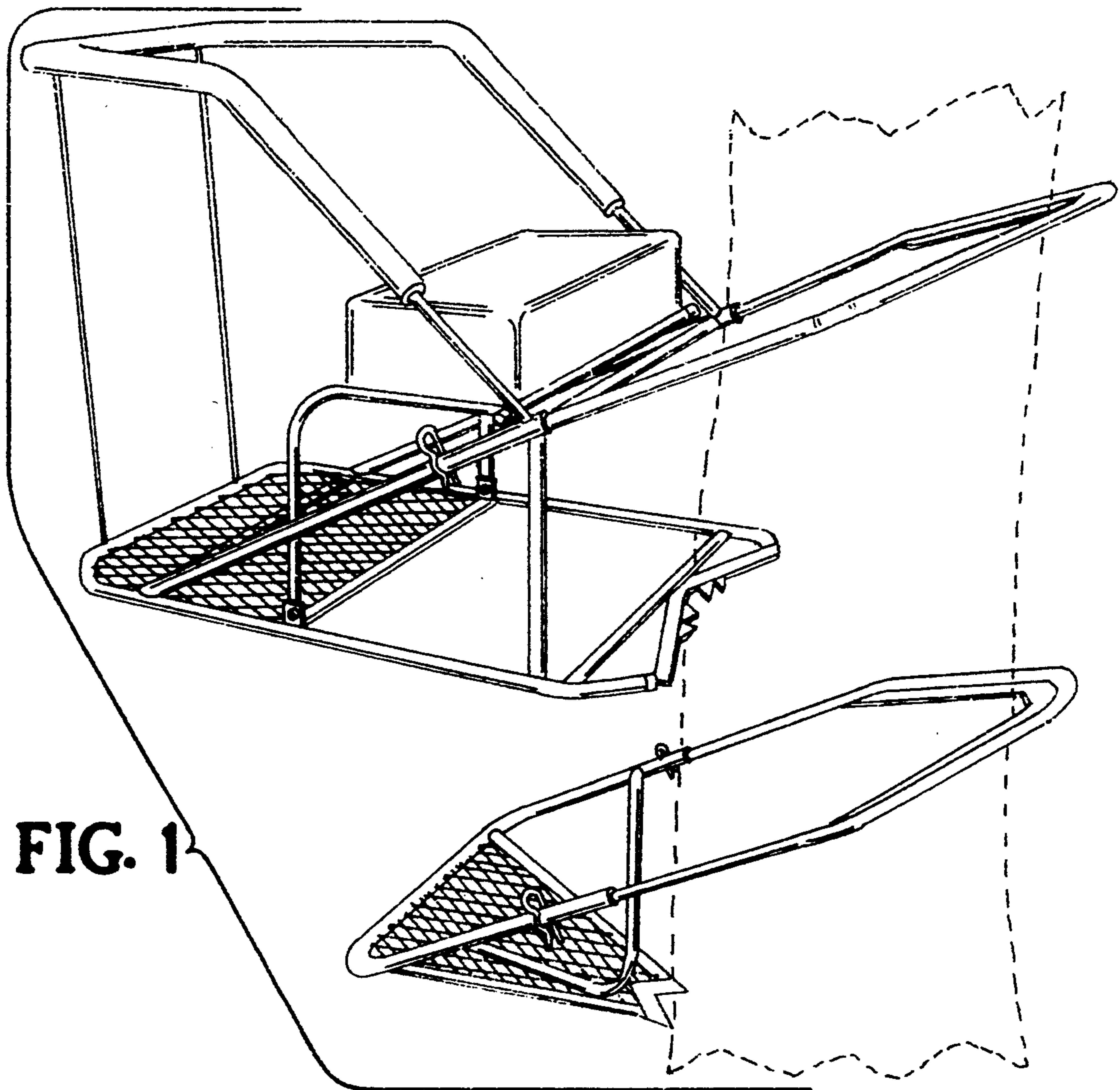

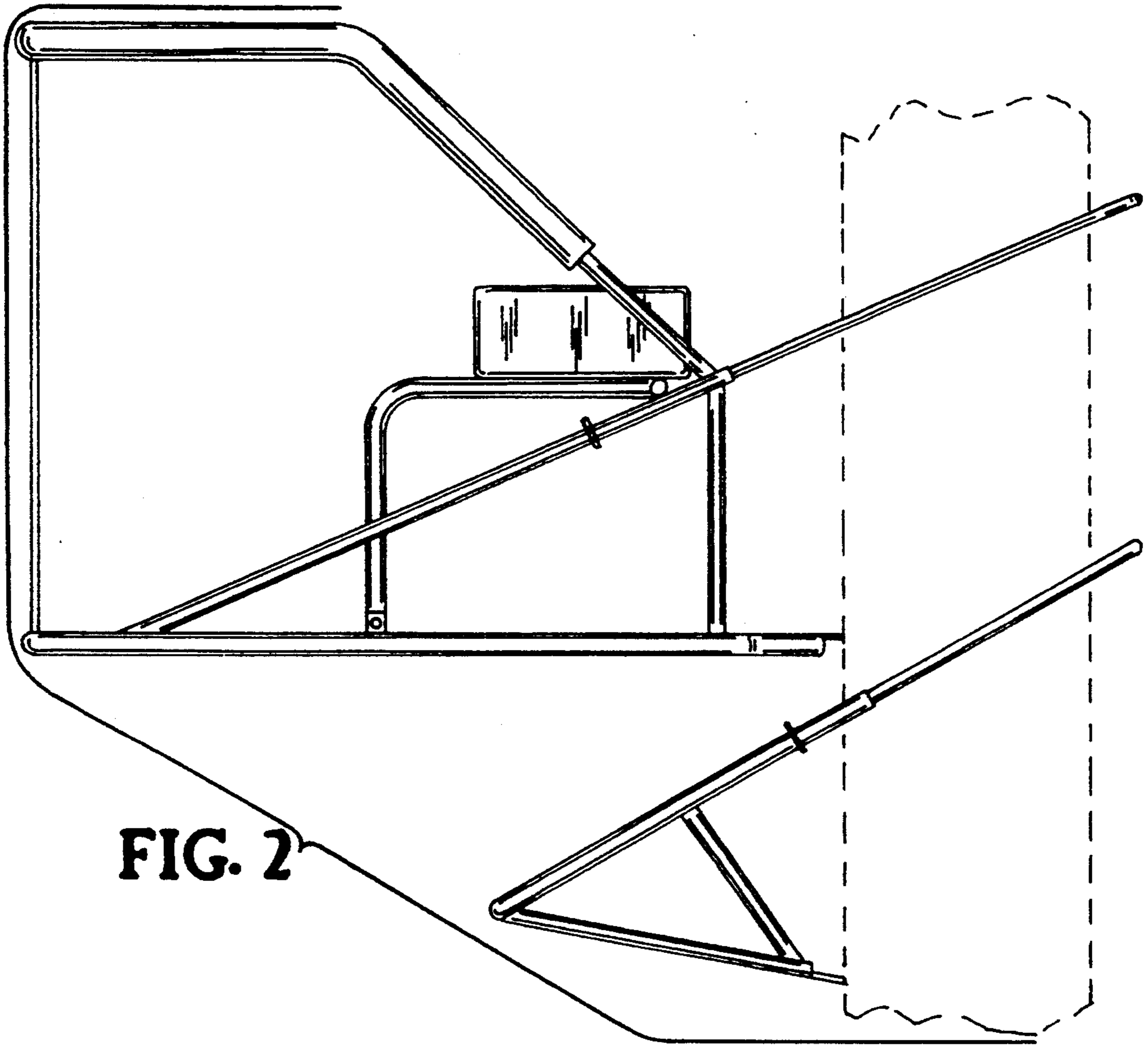

FIG. 2

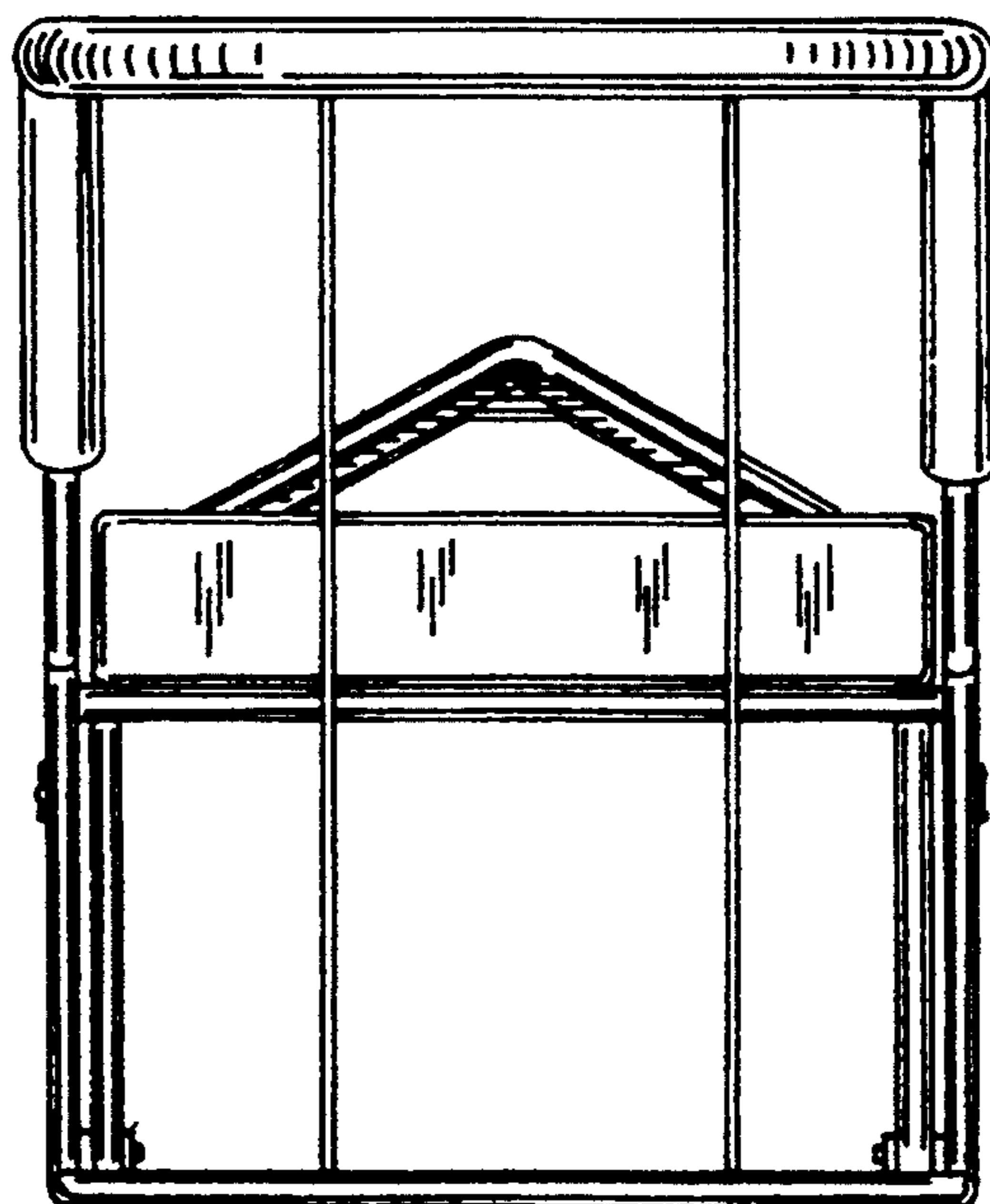

FIG. 4

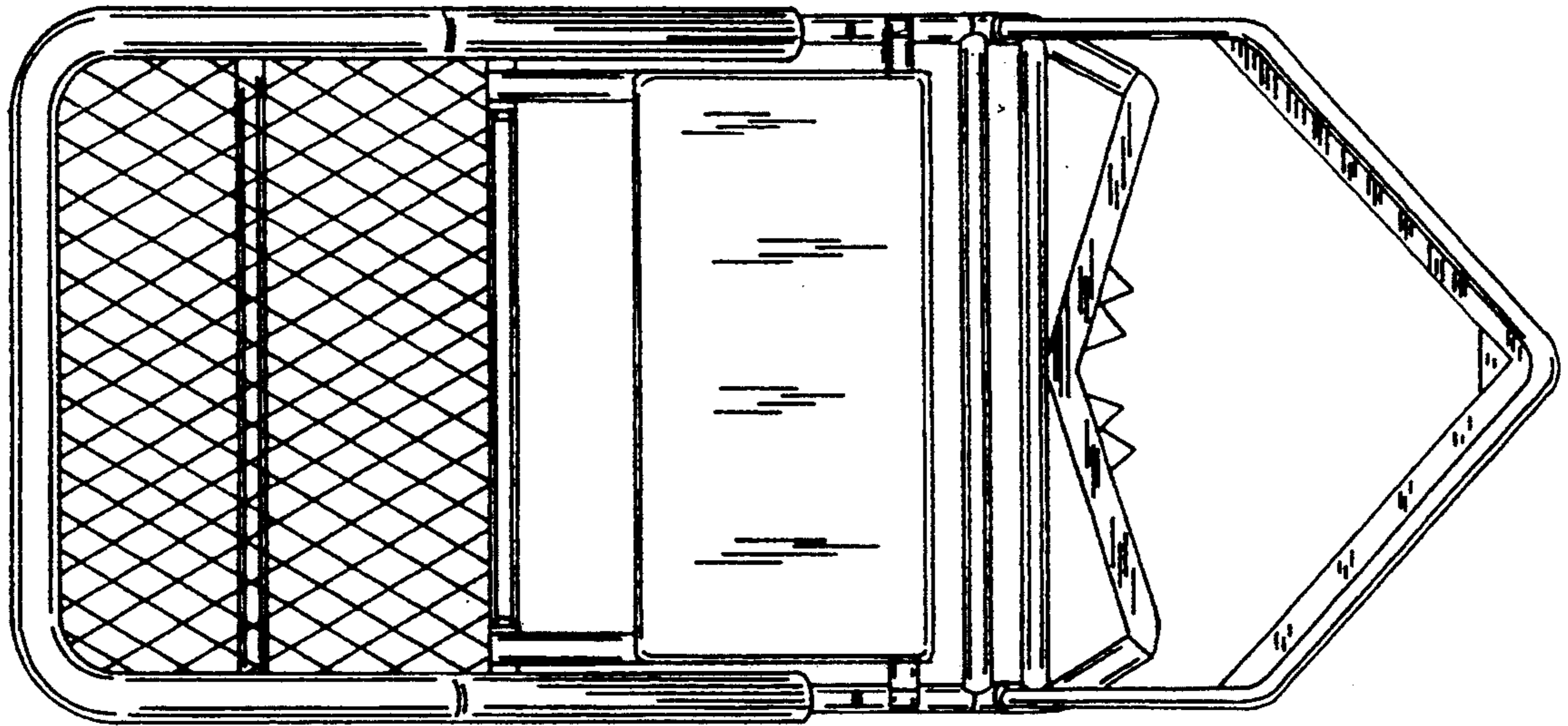

FIG. 5

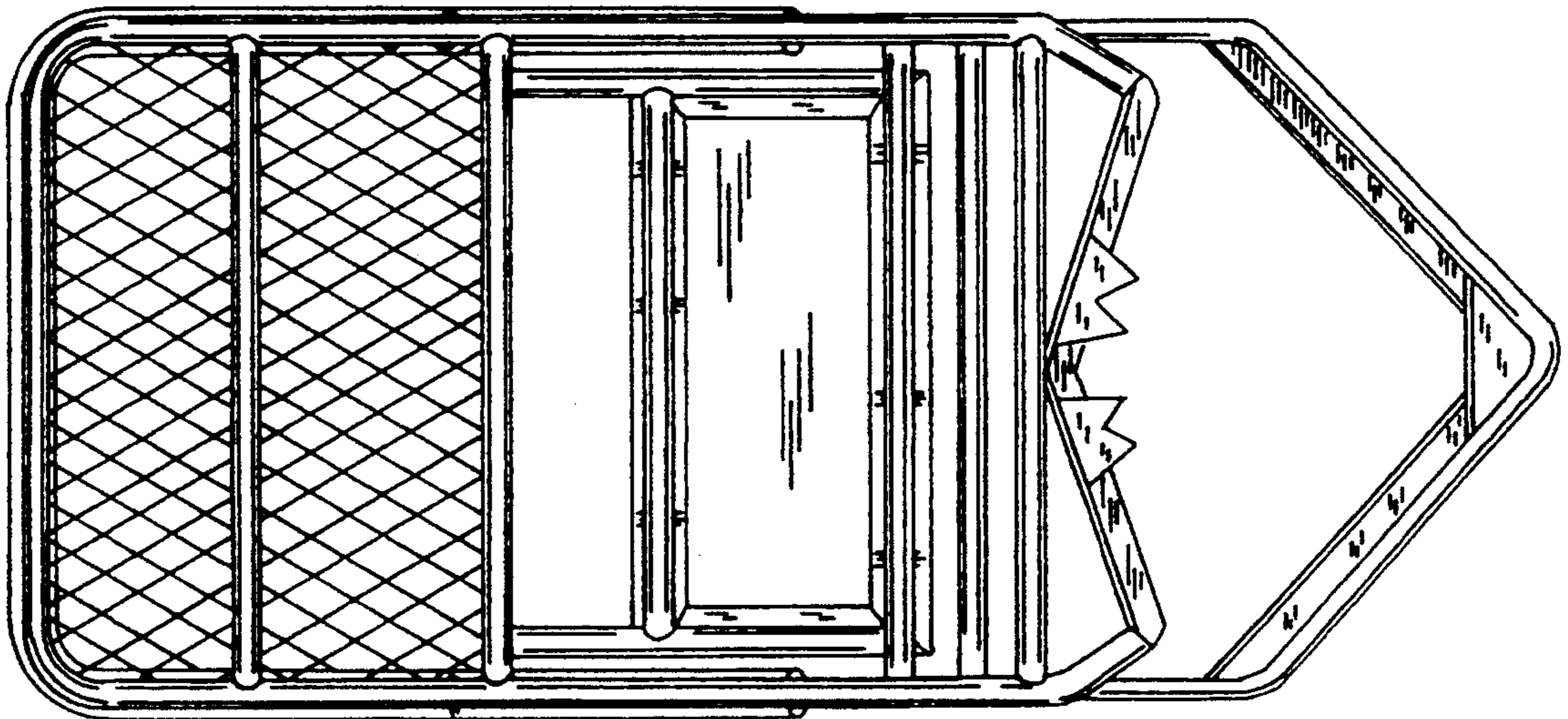

FIG. 6

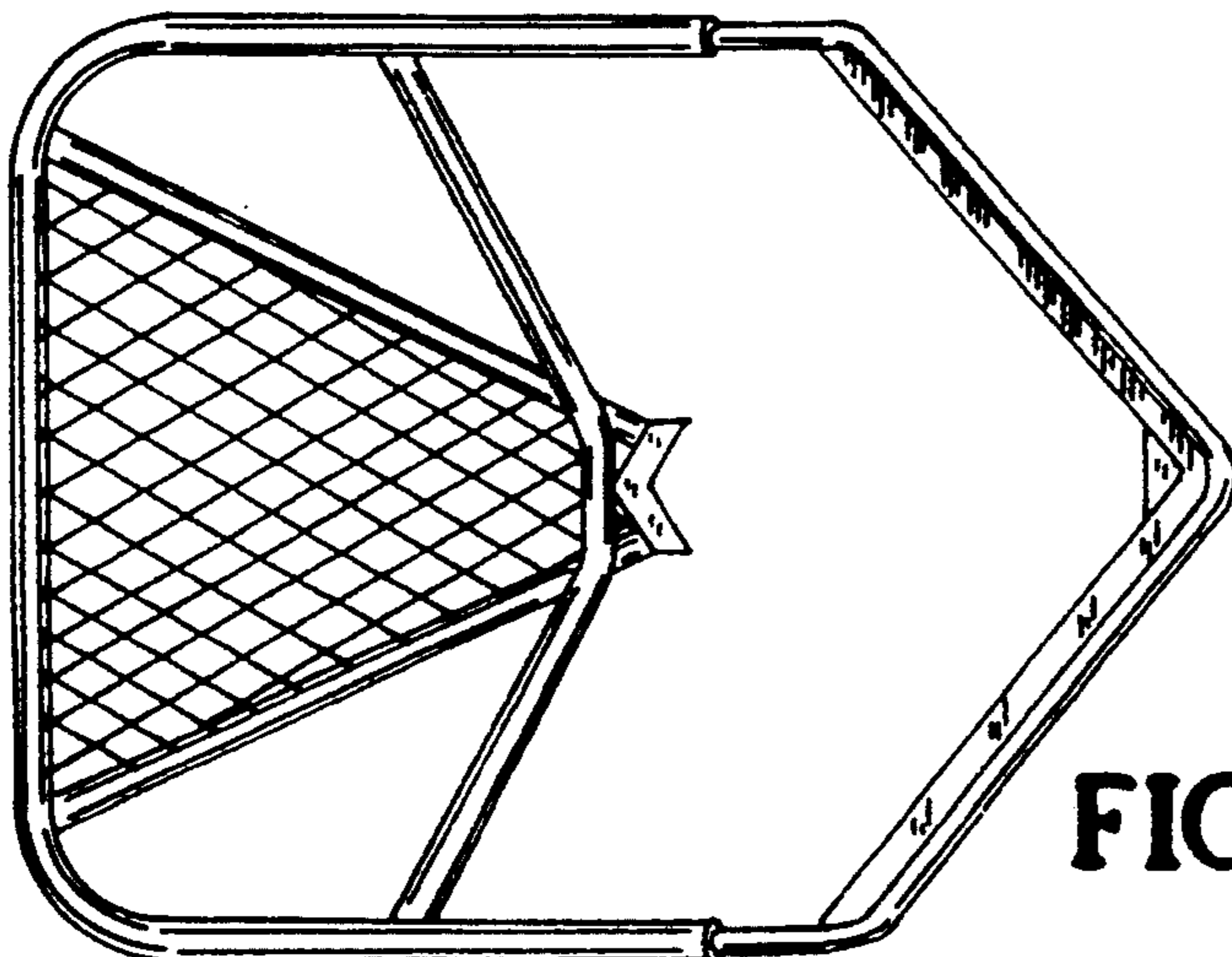

FIG. 7

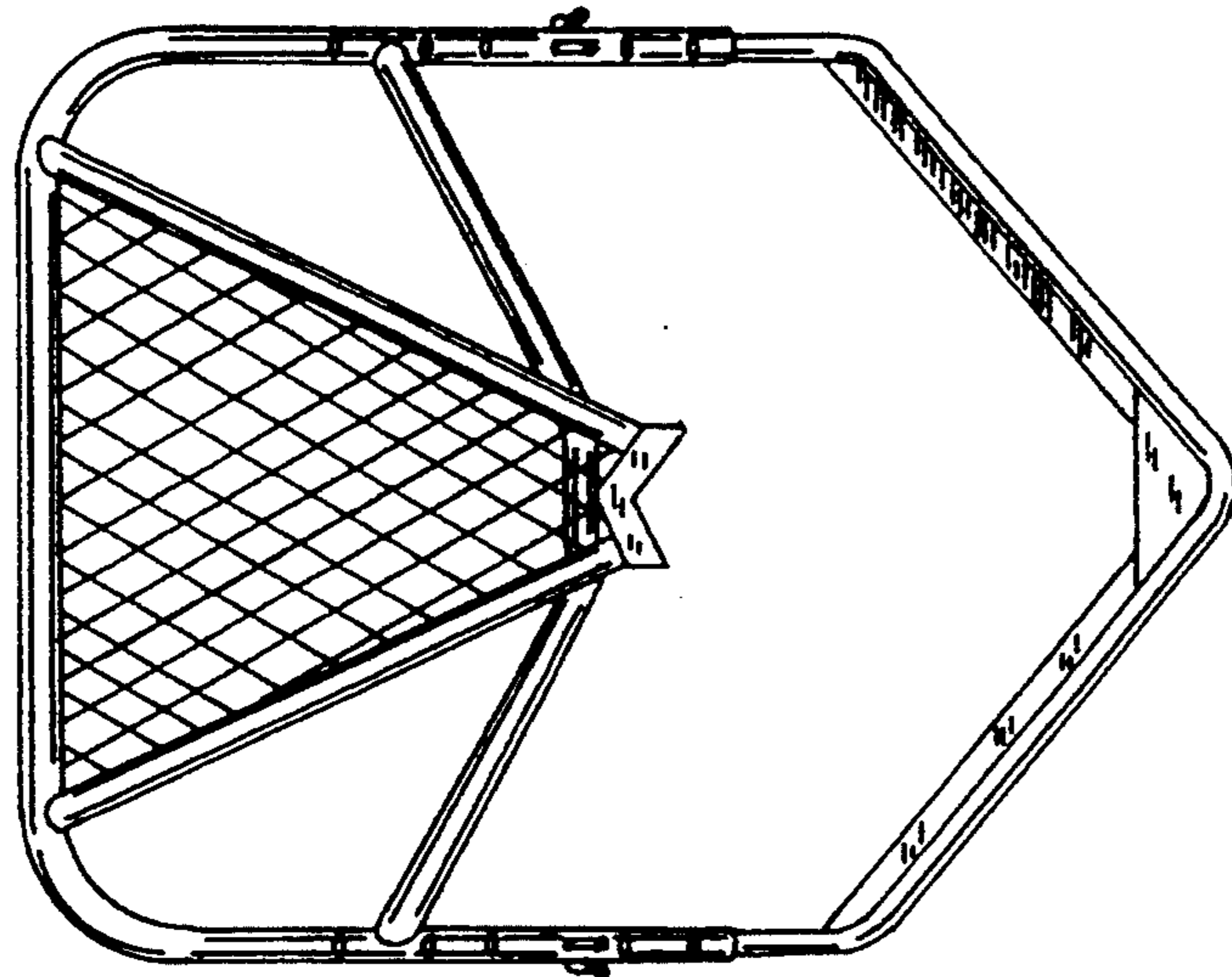

FIG. 8

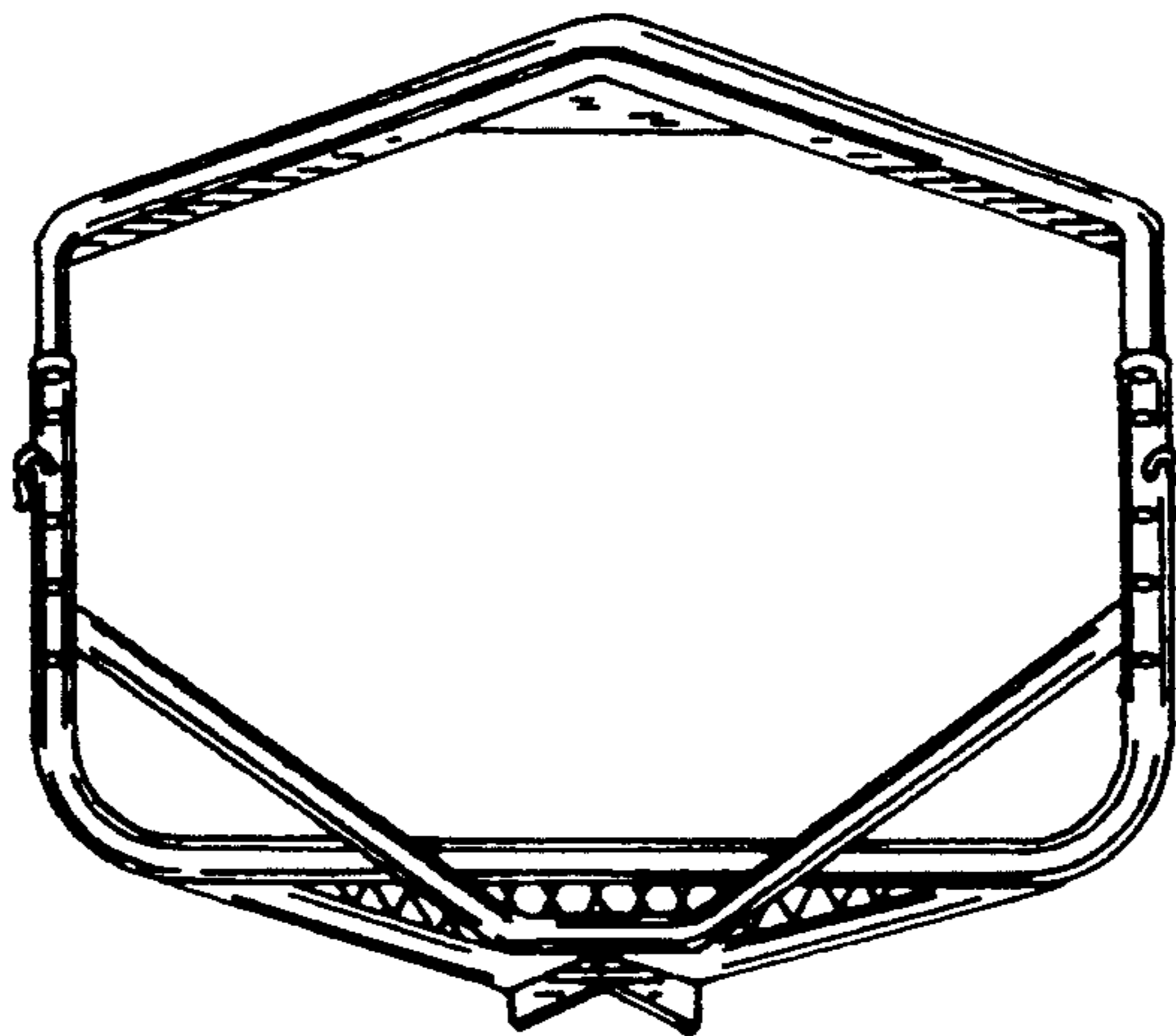

FIG. 9

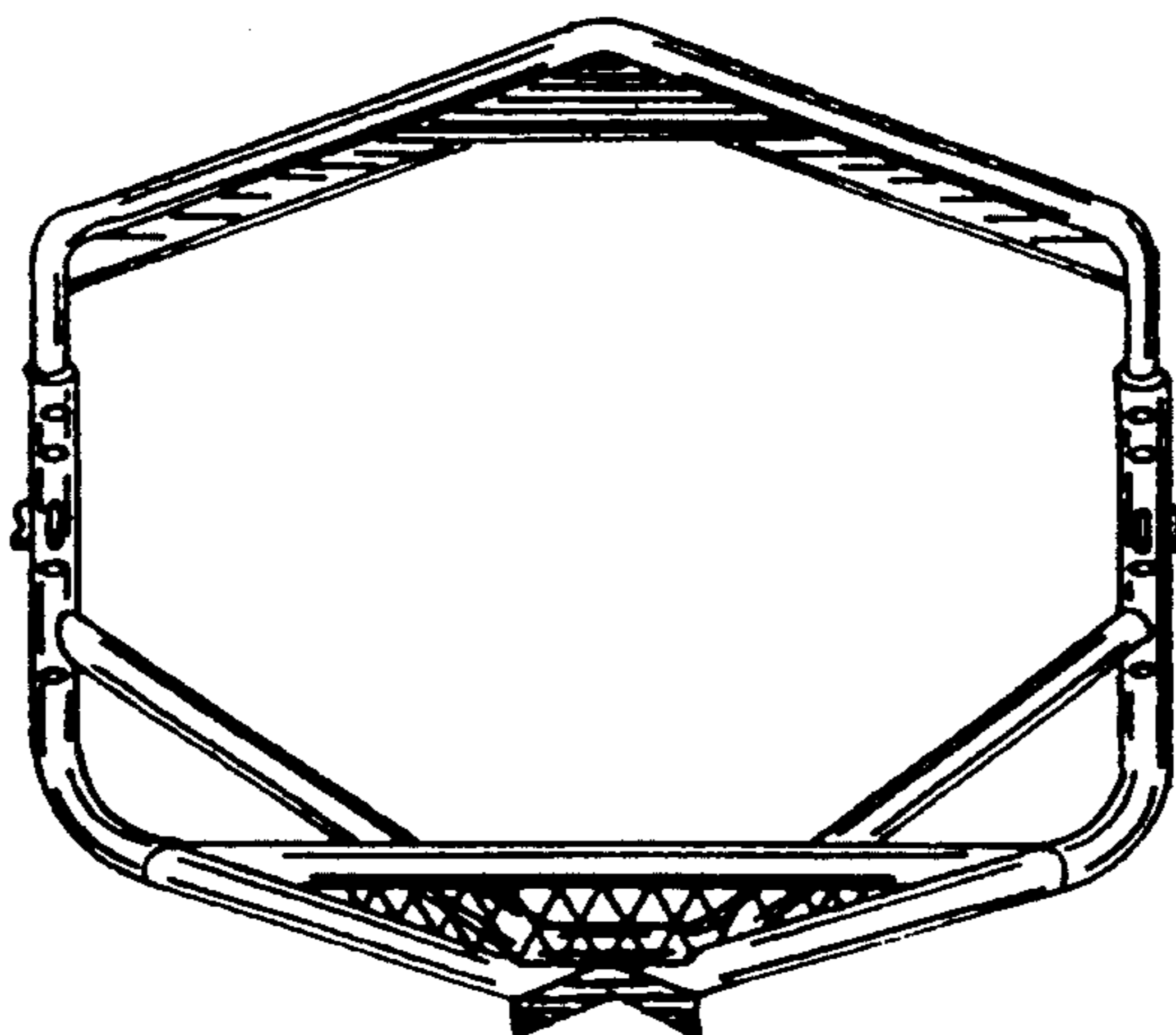

FIG. 10

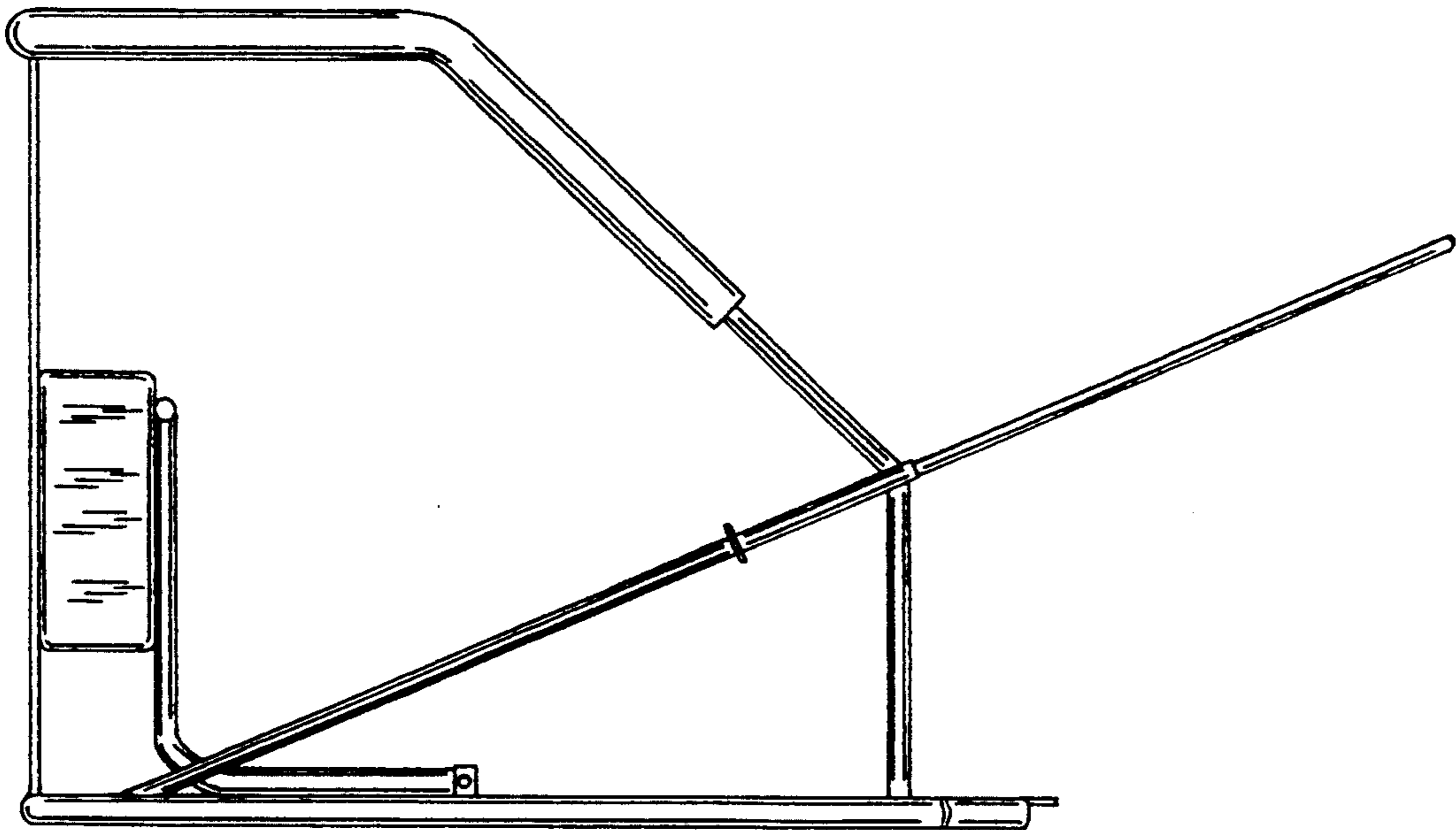

FIG. 11

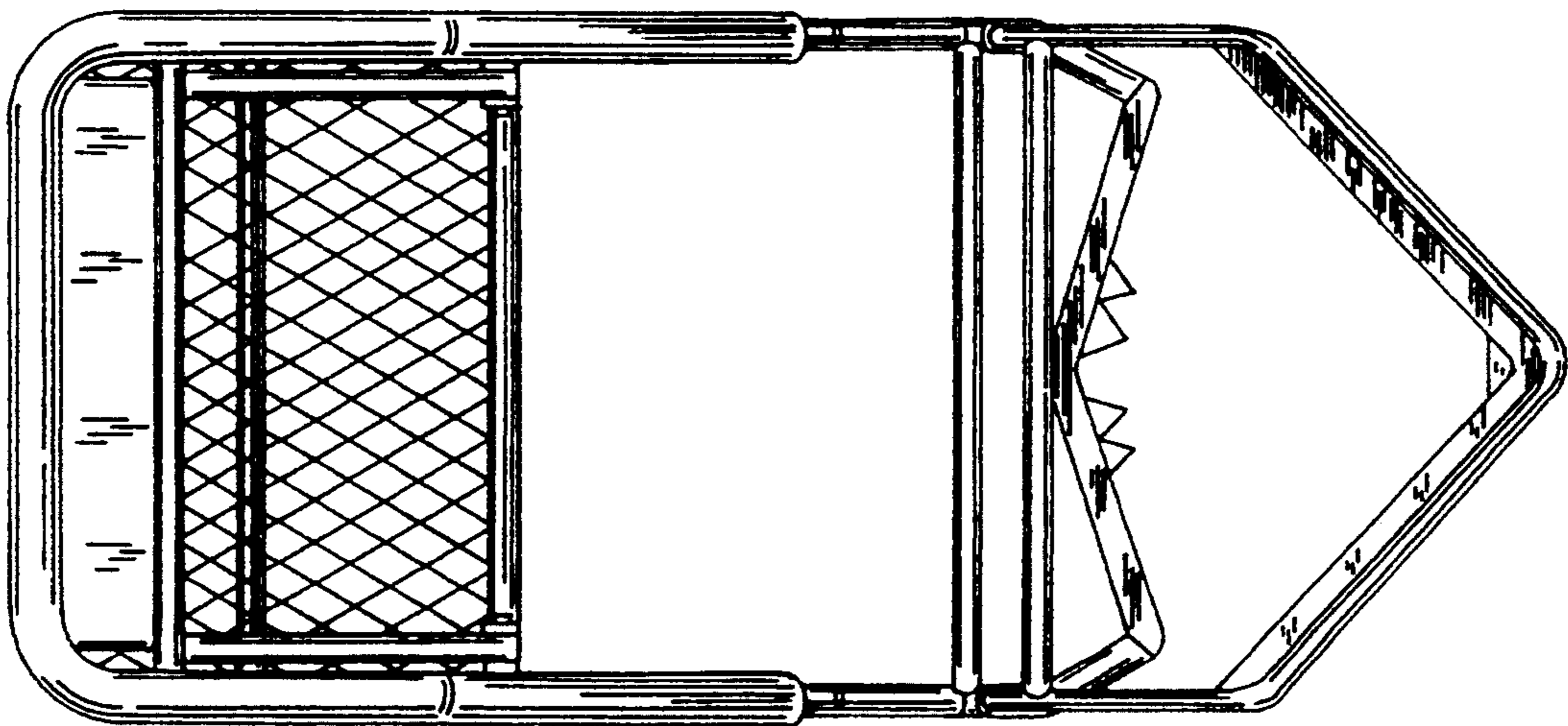

FIG. 12