



US00D353930S

# United States Patent [19]

[11] Patent Number: **Des. 353,930**

**Johnson**

[45] Date of Patent: **\*\* Dec. 27, 1994**

[54] **JUMP RAMP FOR WHEELED VEHICLES**

4,285,514 8/1981 Romero .

[76] Inventor: **Randy L. Johnson**, 6373 Terrell St., Groves, Tex. 77619-5258

*Primary Examiner*—Wallace R. Burke  
*Assistant Examiner*—Robin V. Taylor  
*Attorney, Agent, or Firm*—Rhodes & Ascolillo

[\*\*] Term: **14 Years**

[21] Appl. No.: **17,630**

[57] **CLAIM**

[22] Filed: **Jan. 19, 1994**

The ornamental design for a jump ramp for wheeled vehicles, as shown.

[52] U.S. Cl. .... **D34/32; D21/244**

[58] Field of Search ..... **D34/32, 28; 119/843; 14/71.1, 71.3, 71.5, 69.5; 414/537, 228, 921; 105/433, 436**

### DESCRIPTION

FIG. 1 is a perspective view of a jump ramp for wheeled vehicles showing my new design therefor; FIG. 2 is a top plan view; FIG. 3 is a bottom plan view; FIG. 4 is a right side elevational view; FIG. 5 is a left side elevational view; FIG. 6 is a rear elevational view; and, FIG. 7 is a front elevational view.

### [56] References Cited

#### U.S. PATENT DOCUMENTS

- D. 246,638 12/1977 Hegedus ..... D34/72
- D. 257,874 1/1981 Sheehan ..... D21/244
- 3,663,015 5/1972 Bynder et al. .... 472/89

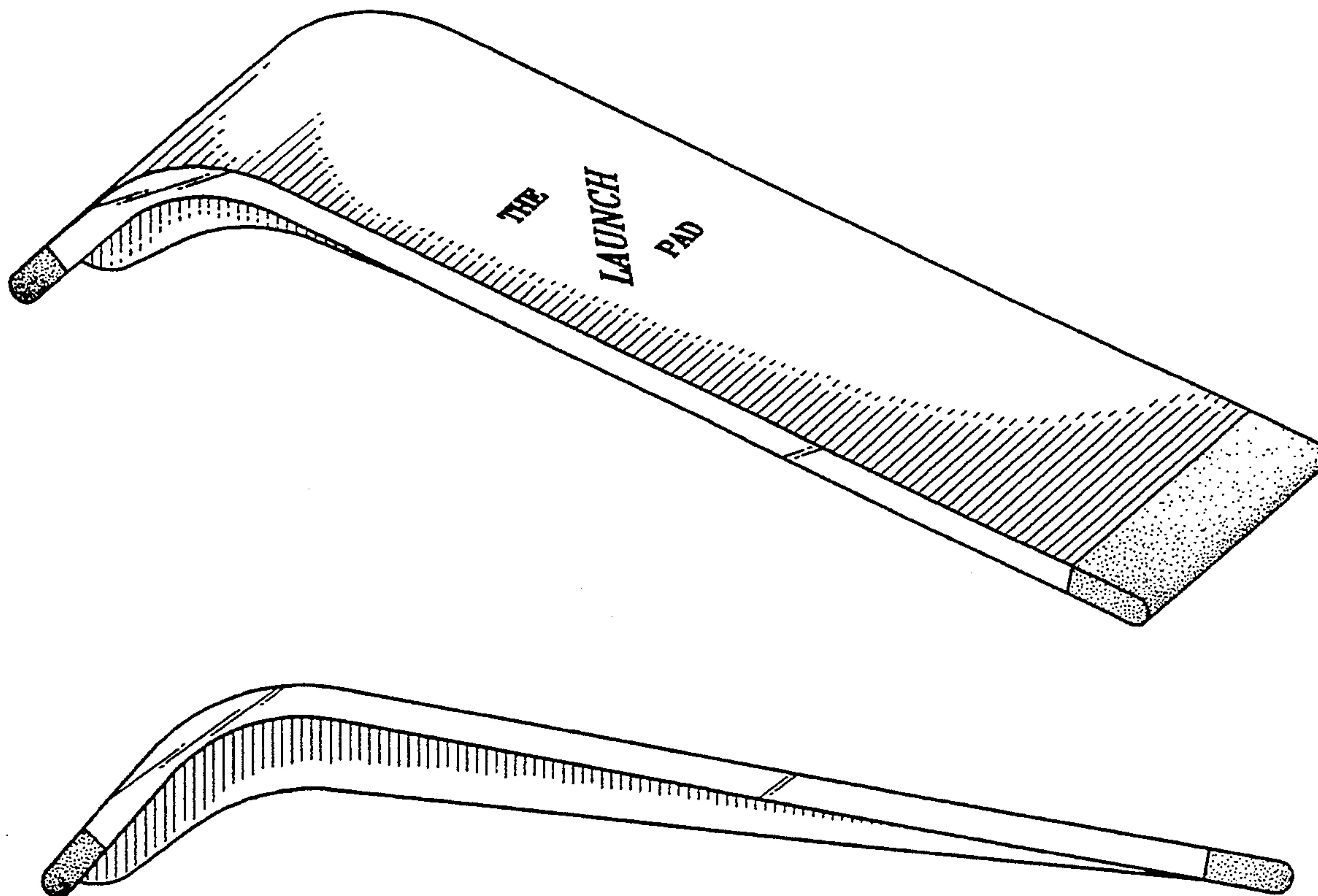

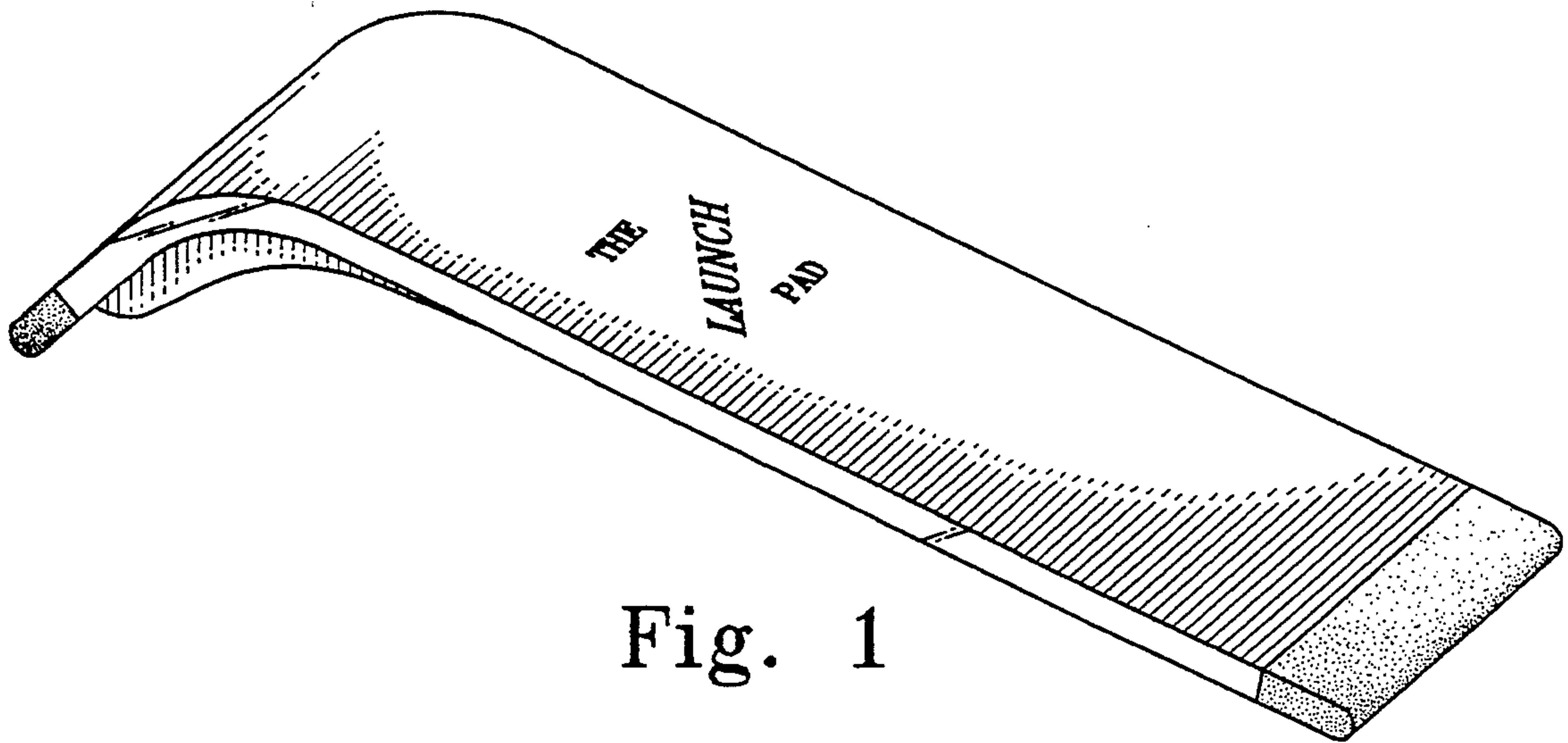

Fig. 1

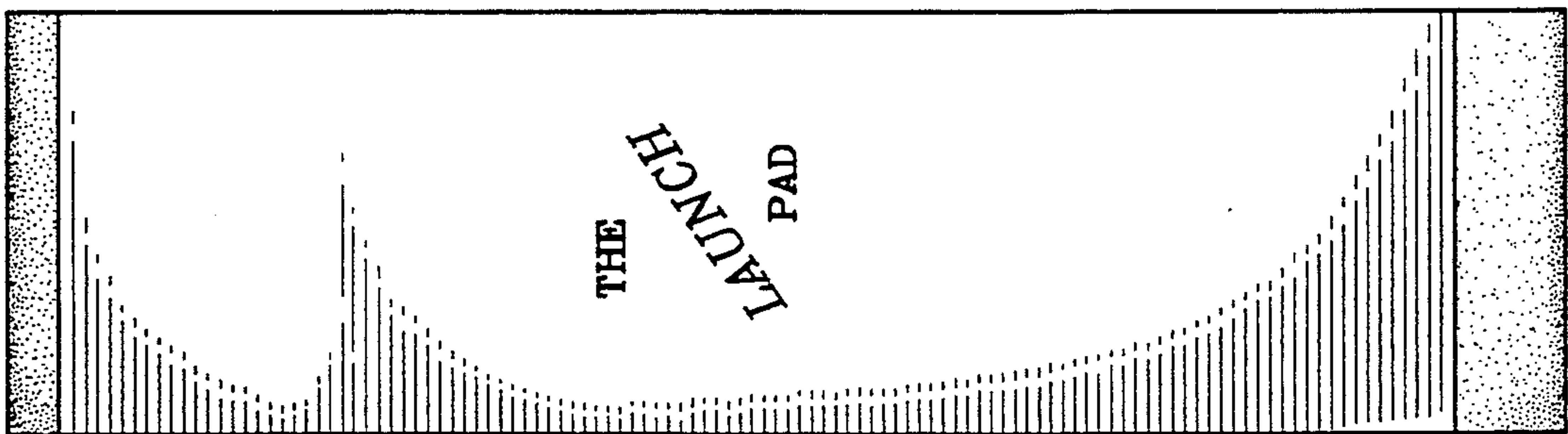

Fig. 2

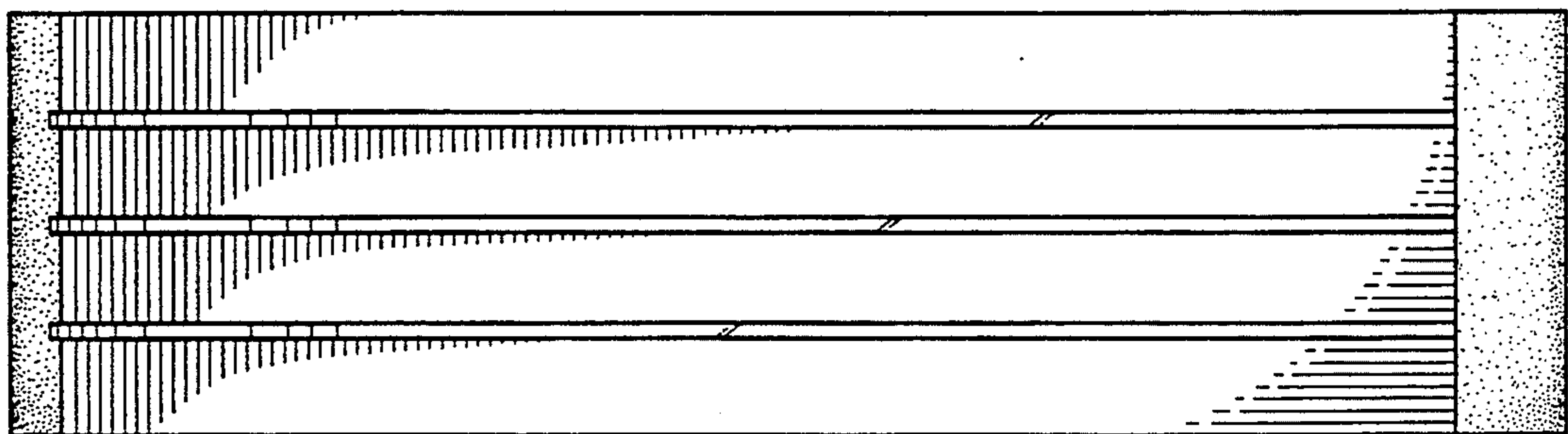

Fig. 3

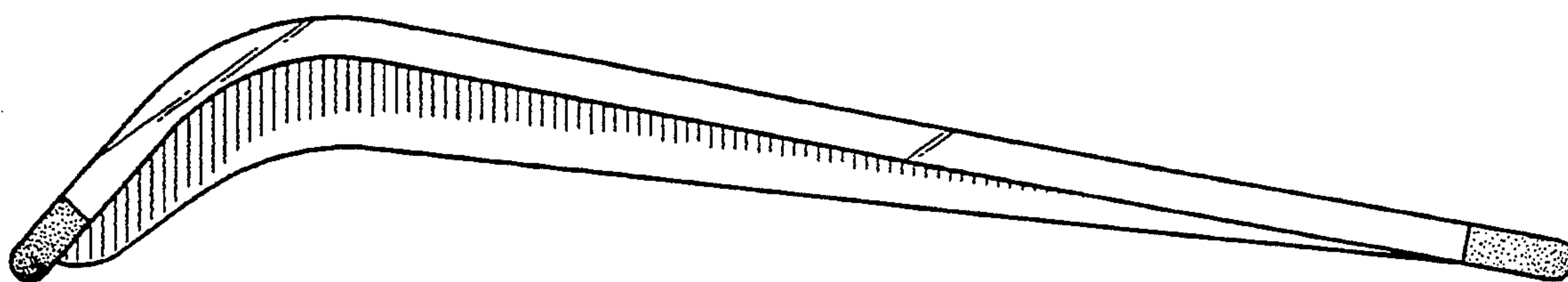

Fig. 4

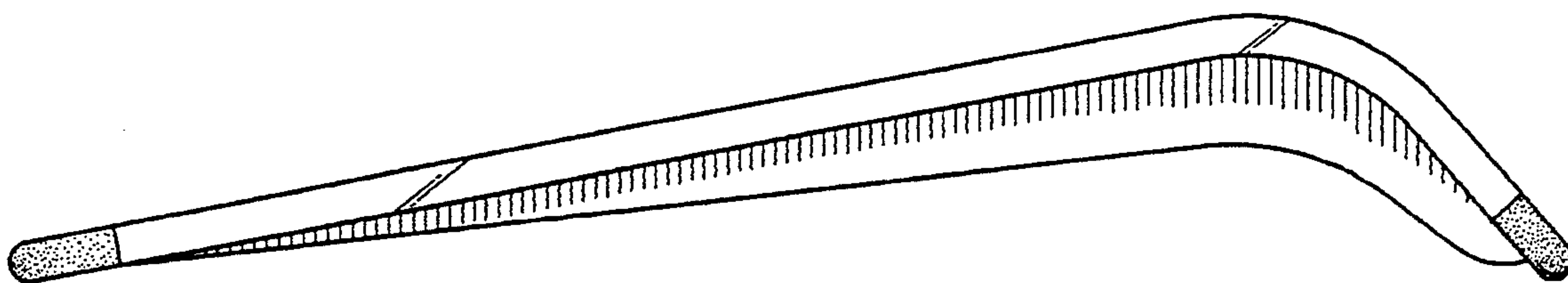

Fig. 5

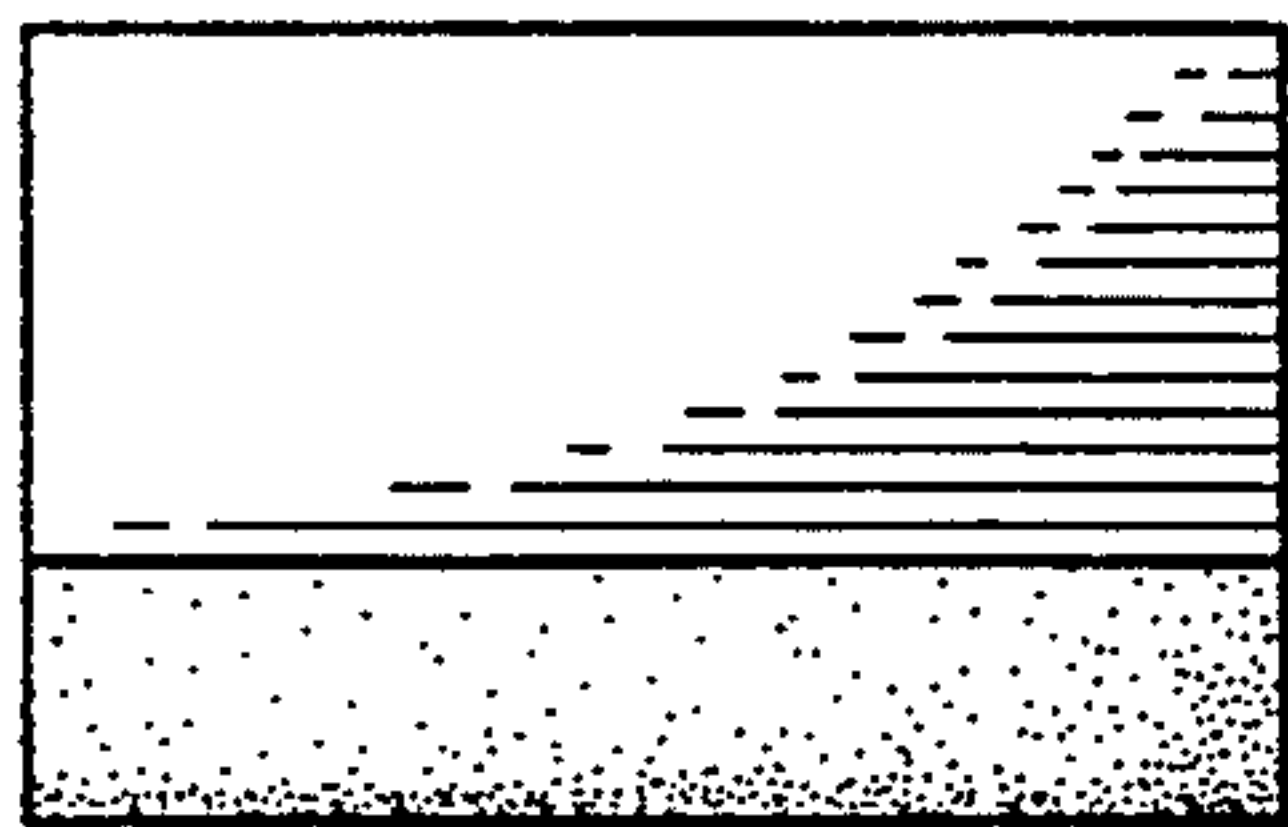

Fig. 6

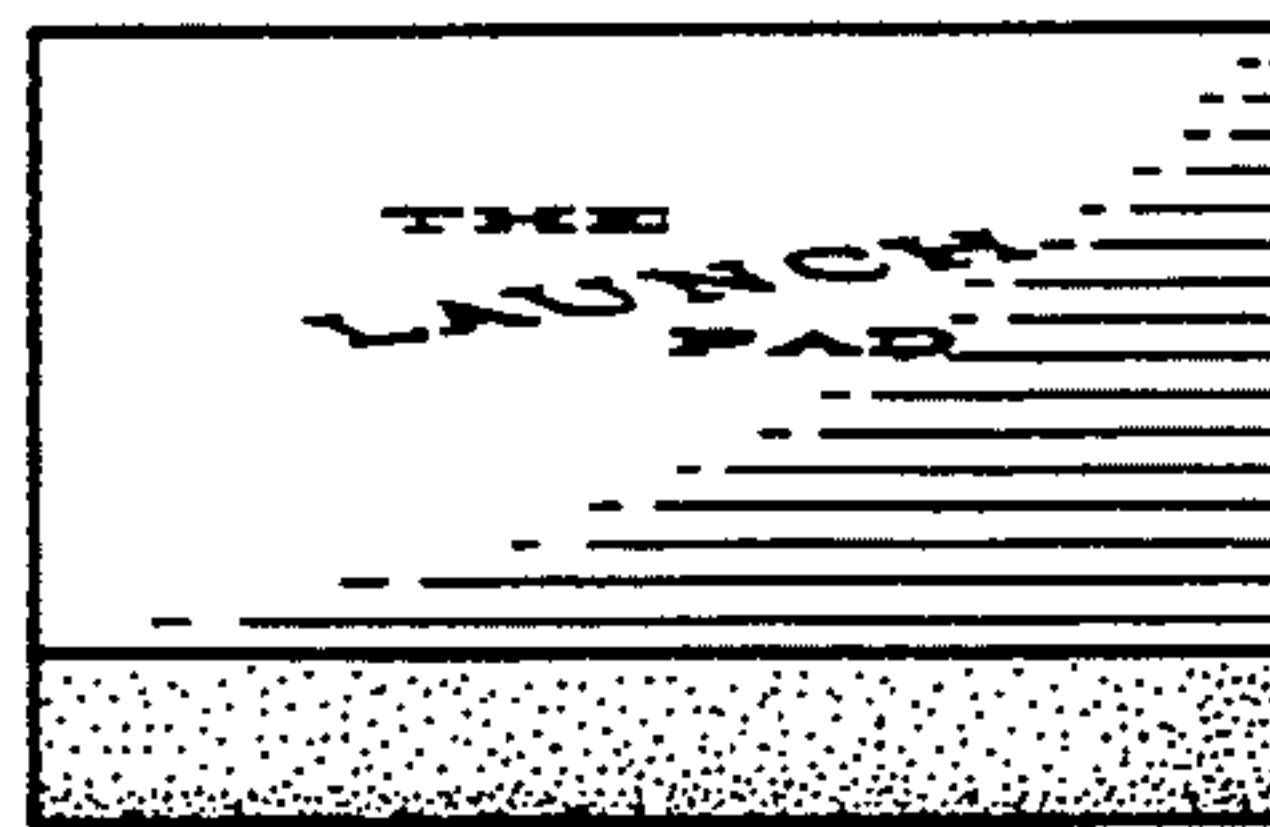

Fig. 7