



US00D353794S

United States Patent [19]

[11] Patent Number: **Des. 353,794**

Stanesic

[45] Date of Patent: **** Dec. 27, 1994**

[54] **BUG AND GRAVEL SHIELD FOR OVER THE ROAD TRUCKS**

Primary Examiner—James M. Gandy
Attorney, Agent, or Firm—Zarley, McKee, Thomte, Voorhees, & Sease

[75] Inventor: **John M. Stanesic, Johnson, Iowa**

[57] **CLAIM**

[73] Assignee: **DFM Corporation, Urbandale, Iowa**

The ornamental design for a bug and gravel shield for over the road trucks, as shown and described.

[**] Term: **14 Years**

DESCRIPTION

[21] Appl. No.: **5,762**

FIG. 1 is a perspective view of a bug and gravel shield for over the road trucks showing my new design in position of use, it being understood that the fragmentary broken line depiction of a portion of a truck hood is for illustrative purposes only and forms no part of the claimed design;

[22] Filed: **Mar. 11, 1993**

[52] U.S. Cl. **D12/181**

FIG. 2 is a rear elevation view thereof;

[58] Field of Search **D12/181, 190; 296/91, 296/180.1, 180.4**

FIG. 3 is a top plan view thereof;

[56] **References Cited**

U.S. PATENT DOCUMENTS

D. 307,569	5/1990	Ziegler et al.	D12/181
3,015,517	1/1962	Thornburgh	296/91
4,153,129	5/1979	Redmond	180/68 P
4,627,657	12/1986	Daniels et al.	296/91

FIG. 4 is a front elevation view thereof; and,

FIG. 5 is an end elevation view thereof, it being understood that the opposite end is a mirror image of that shown.

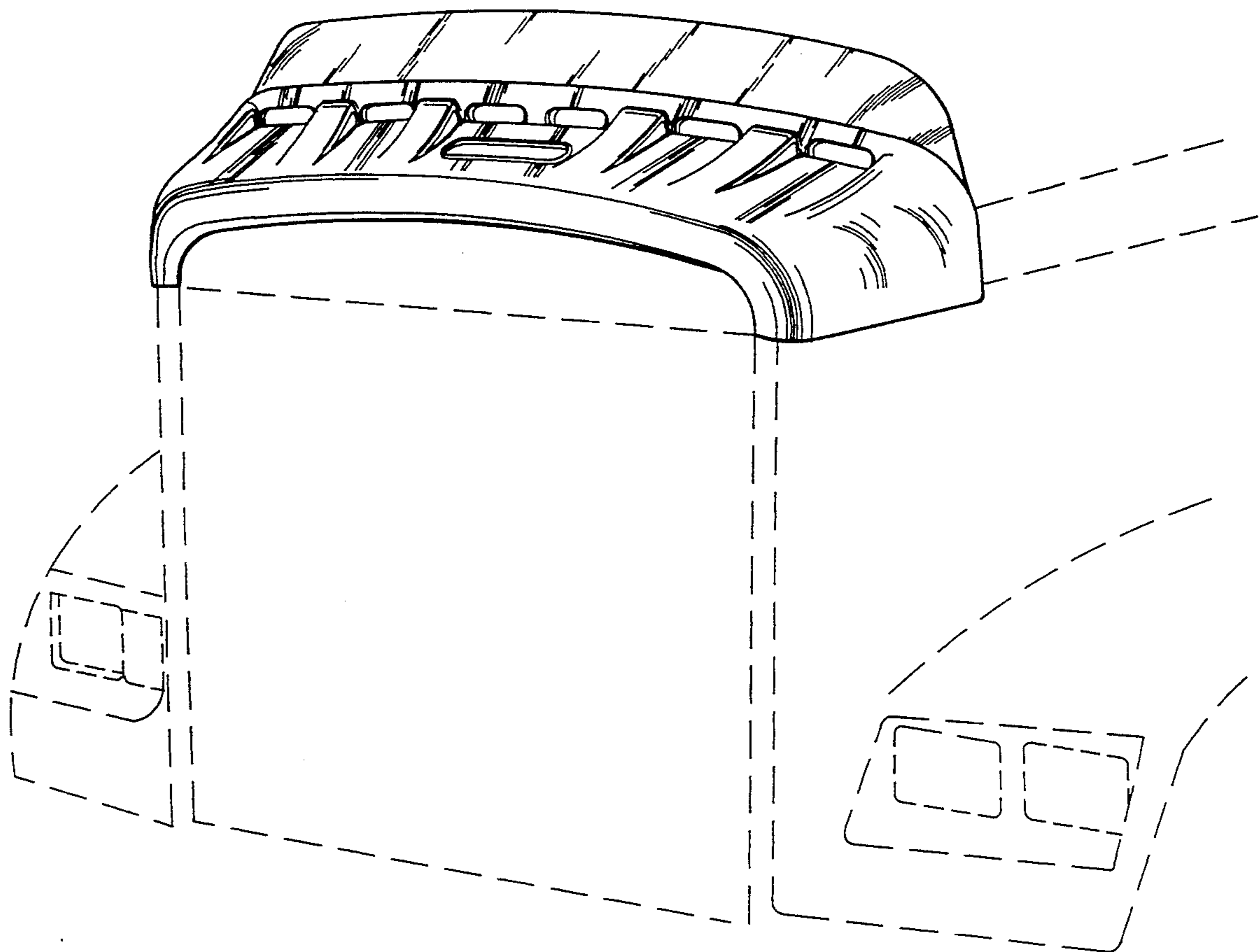

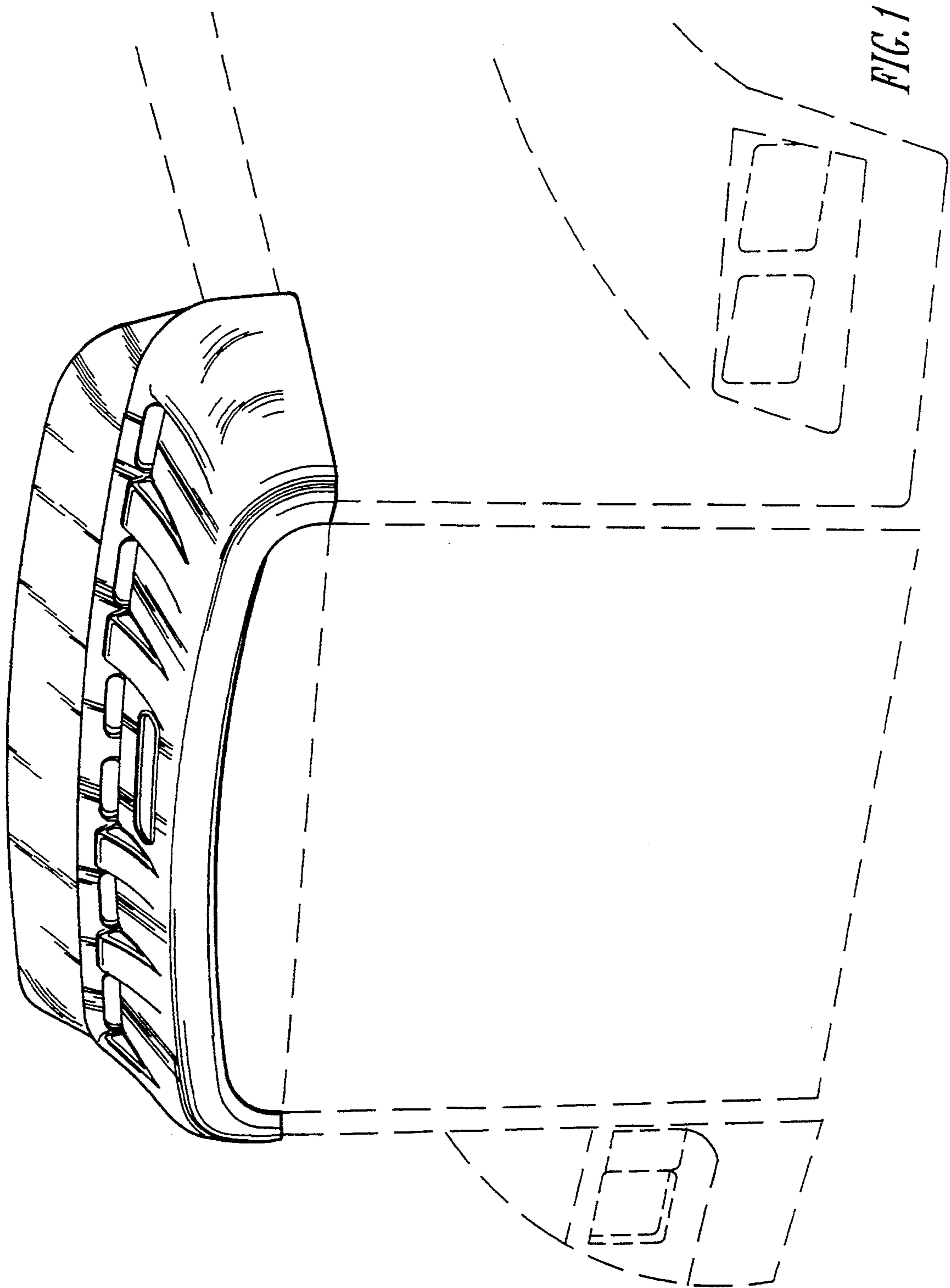

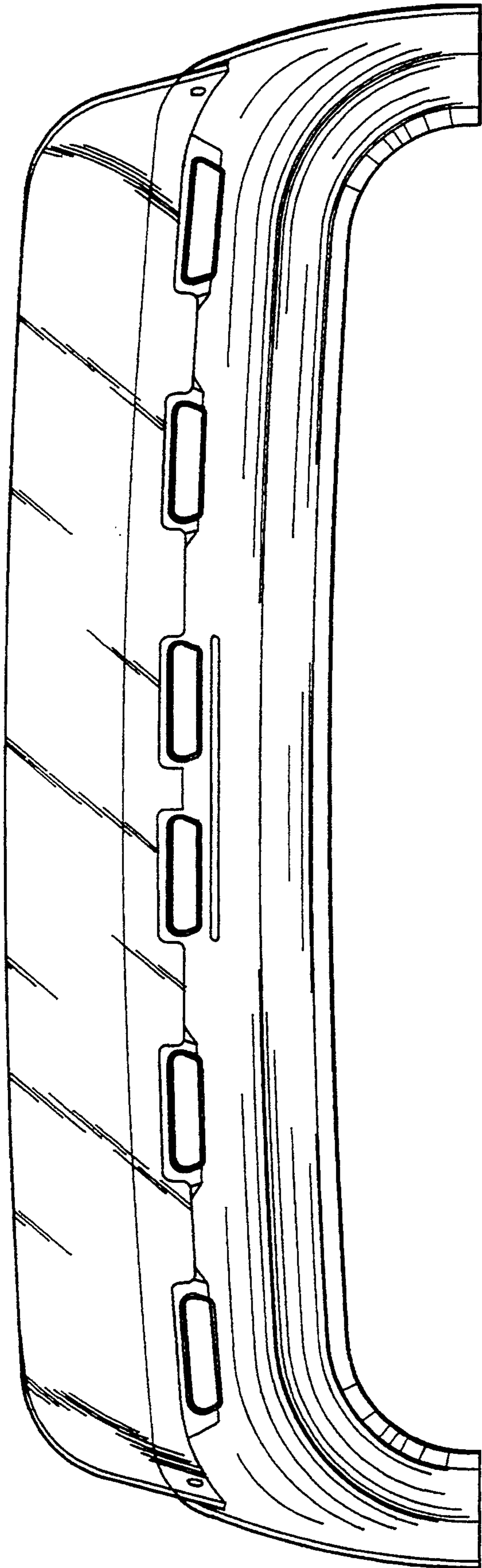

FIG. 2

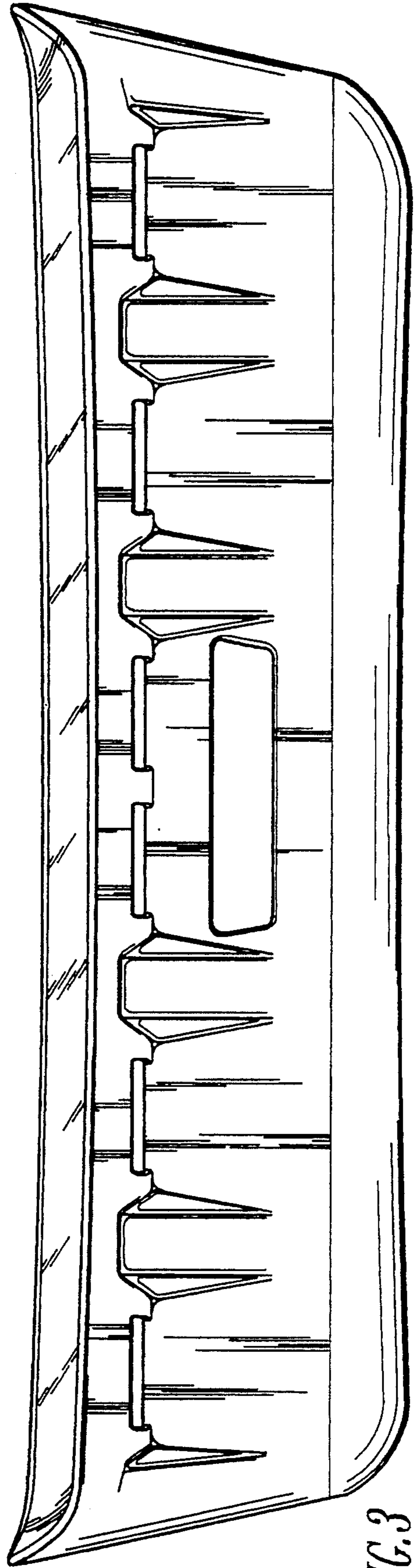

FIG. 3

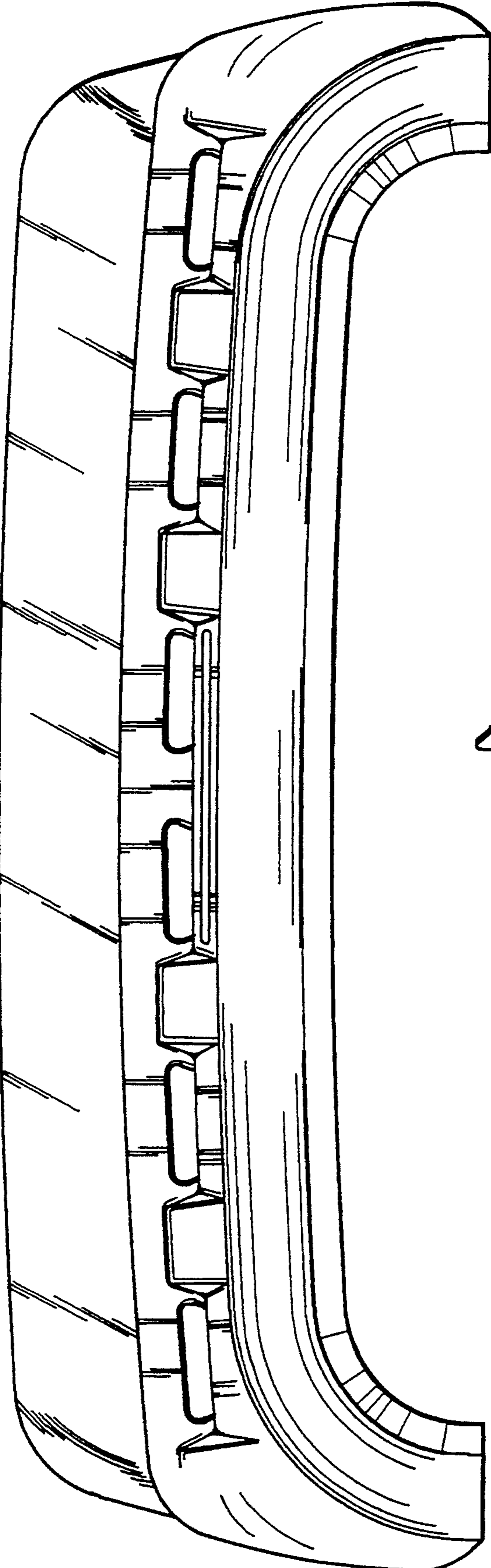

FIG. 4

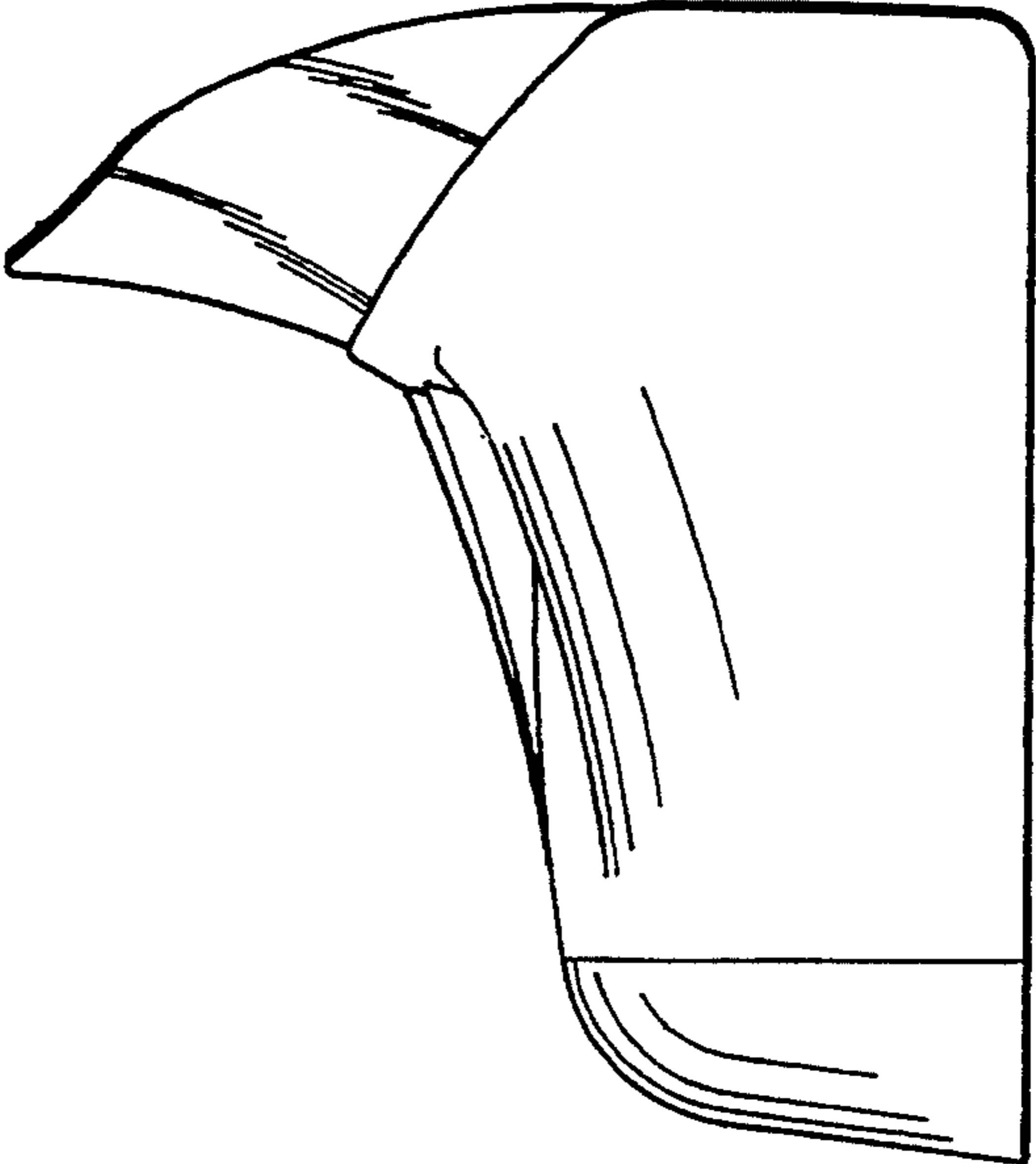

FIG. 5