



US00D353698S

United States Patent [19]

[11] Patent Number: **Des. 353,698**

Stevens et al.

[45] Date of Patent: **** Dec. 20, 1994**

[54] **MOTORIZED GOLF BAG CART**

5,322,306 6/1994 Coleman 280/33.991

[76] Inventors: **Ronald D. Stevens**, 704 Hacienda Pl., Camarillo, Calif. 93012; **Robert Allen**, 4934 Doman Ave., Tarzana, Calif. 91356

Primary Examiner—Kay H. Chin
Attorney, Agent, or Firm—Blakely, Sokoloff, Taylor & Zafman

[**] Term: **14 Years**

[57] **CLAIM**

The ornamental design for a motorized golf bag cart, as shown and described.

[21] Appl. No.: **11,690**

DESCRIPTION

[22] Filed: **Aug. 12, 1993**

[52] U.S. Cl. **D34/15; D34/17**

[58] Field of Search 280/DIG. 5, DIG. 6, 280/33.991, 47.11; 180/167, 19.1; D34/12, 15

FIG. 1 is a front, top and left side perspective view of the motorized gold bag cart showing our new design, the broken lines are for illustrative purposes only and form no part of the claimed design;
FIG. 2 is a rear right side top perspective view thereof;
FIG. 3 is a front elevation thereof;
FIG. 4 is a rear elevation thereof;
FIG. 5 is a top plan view thereof;
FIG. 6 is a right side elevation thereof;
FIG. 7 is a left side elevation thereof; and,
FIG. 8 is a bottom plan view thereof.

[56] **References Cited**

U.S. PATENT DOCUMENTS

3,648,795	3/1972	Moulton	280/DIG. 5
3,871,464	3/1975	Eden	280/DIG. 5
4,802,547	2/1989	Nakasaki	280/DIG. 5
5,137,103	8/1992	Cartmell	280/DIG. 5

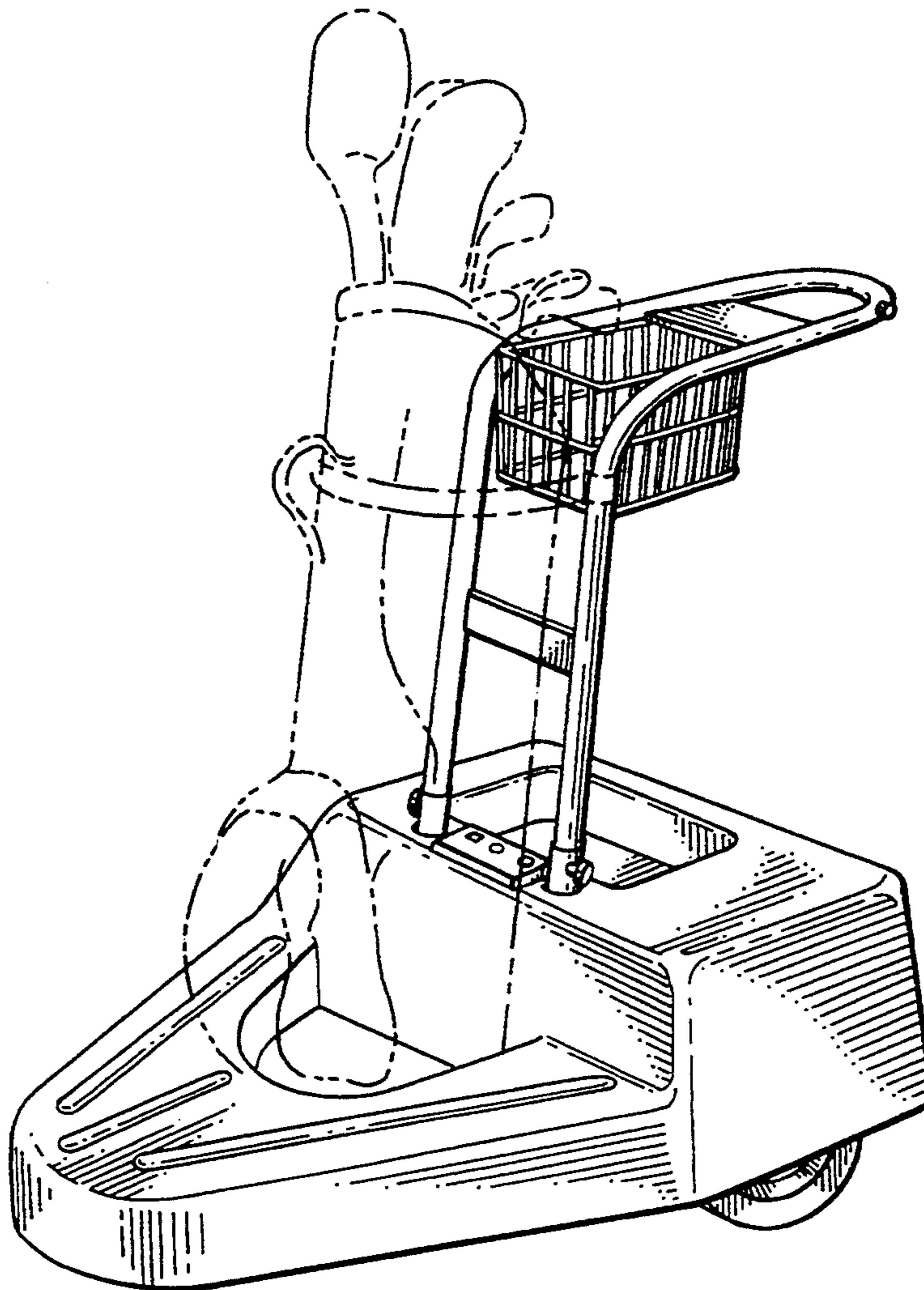

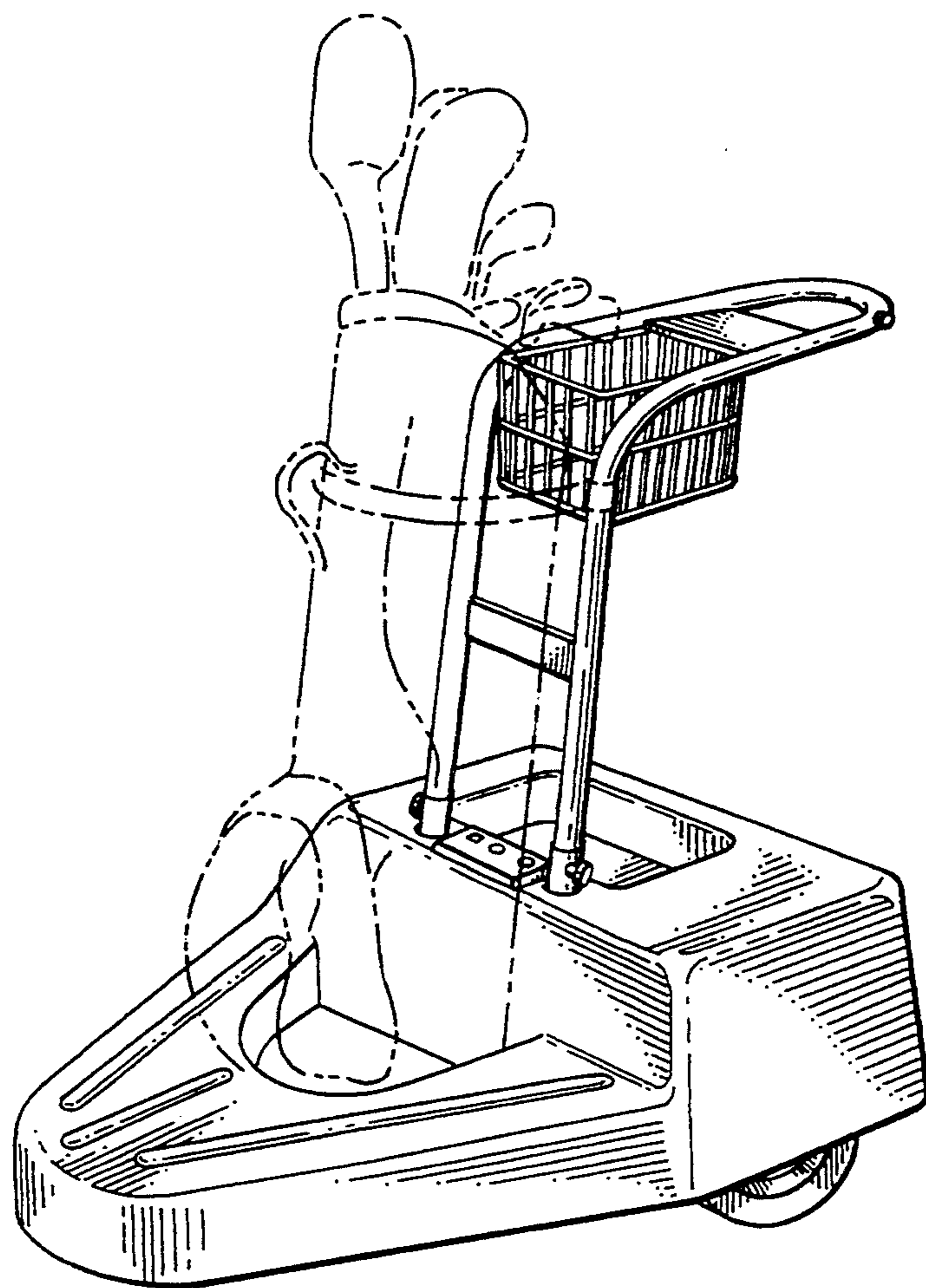

FIG. 1

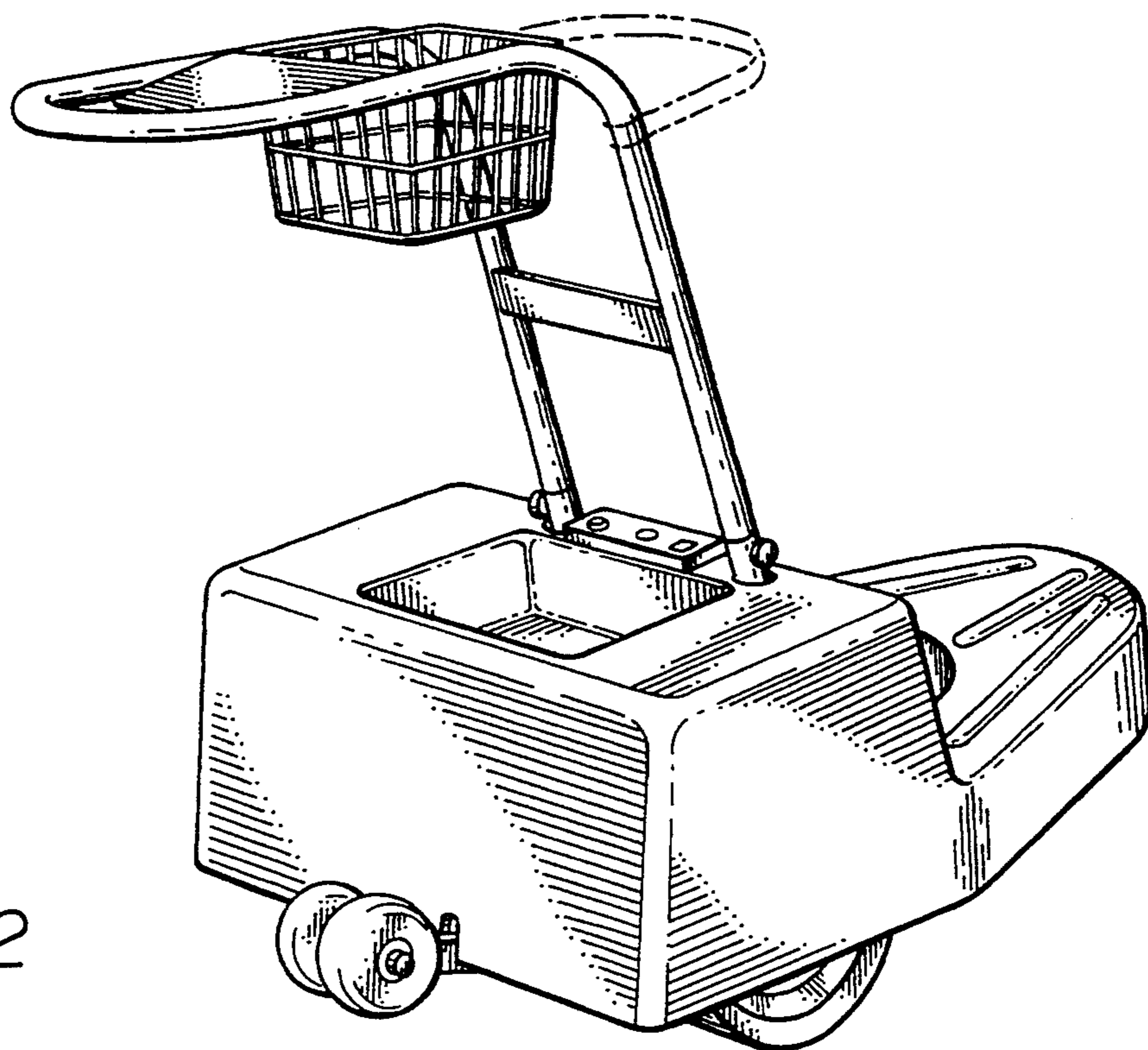

FIG. 2

FIG. 3

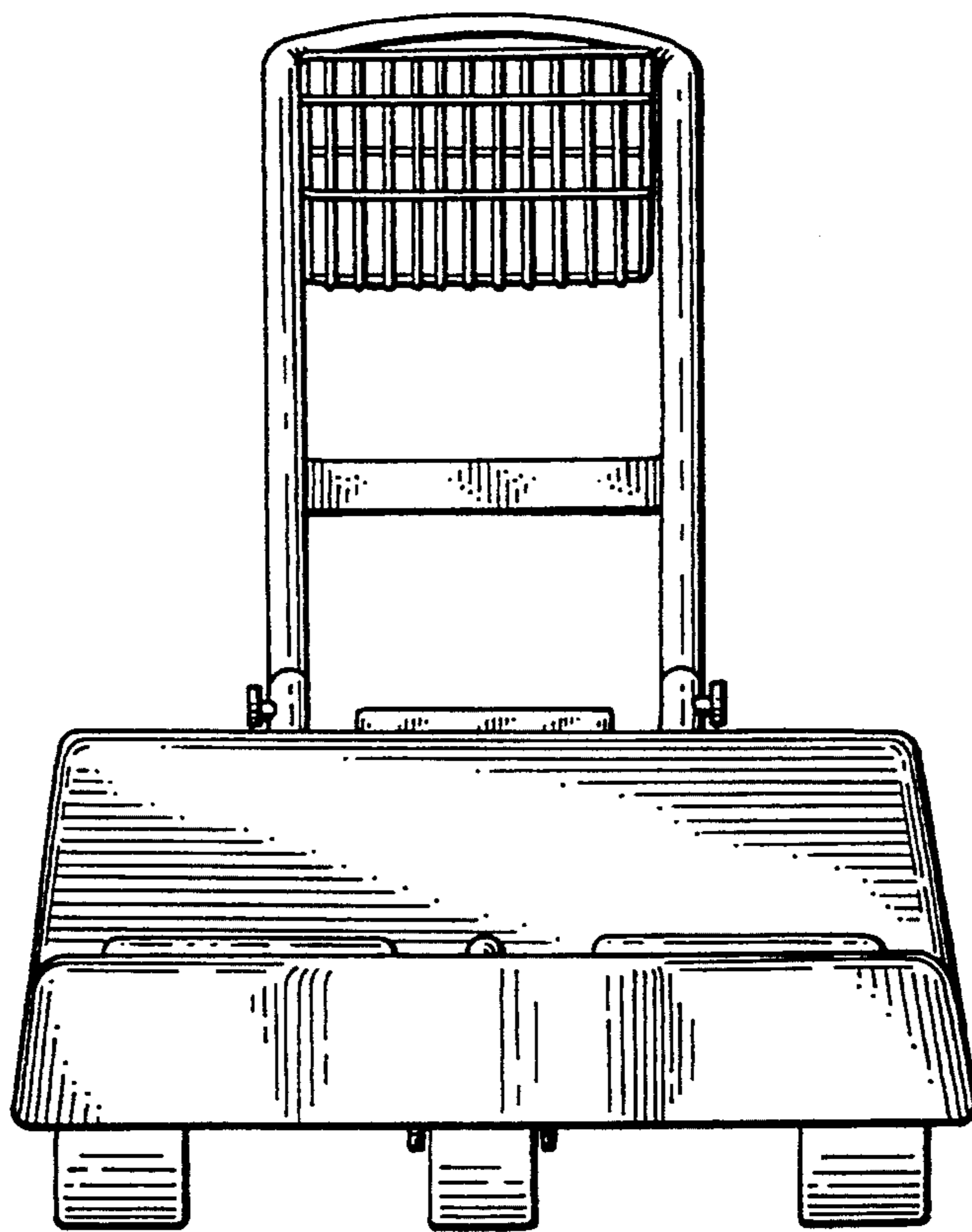
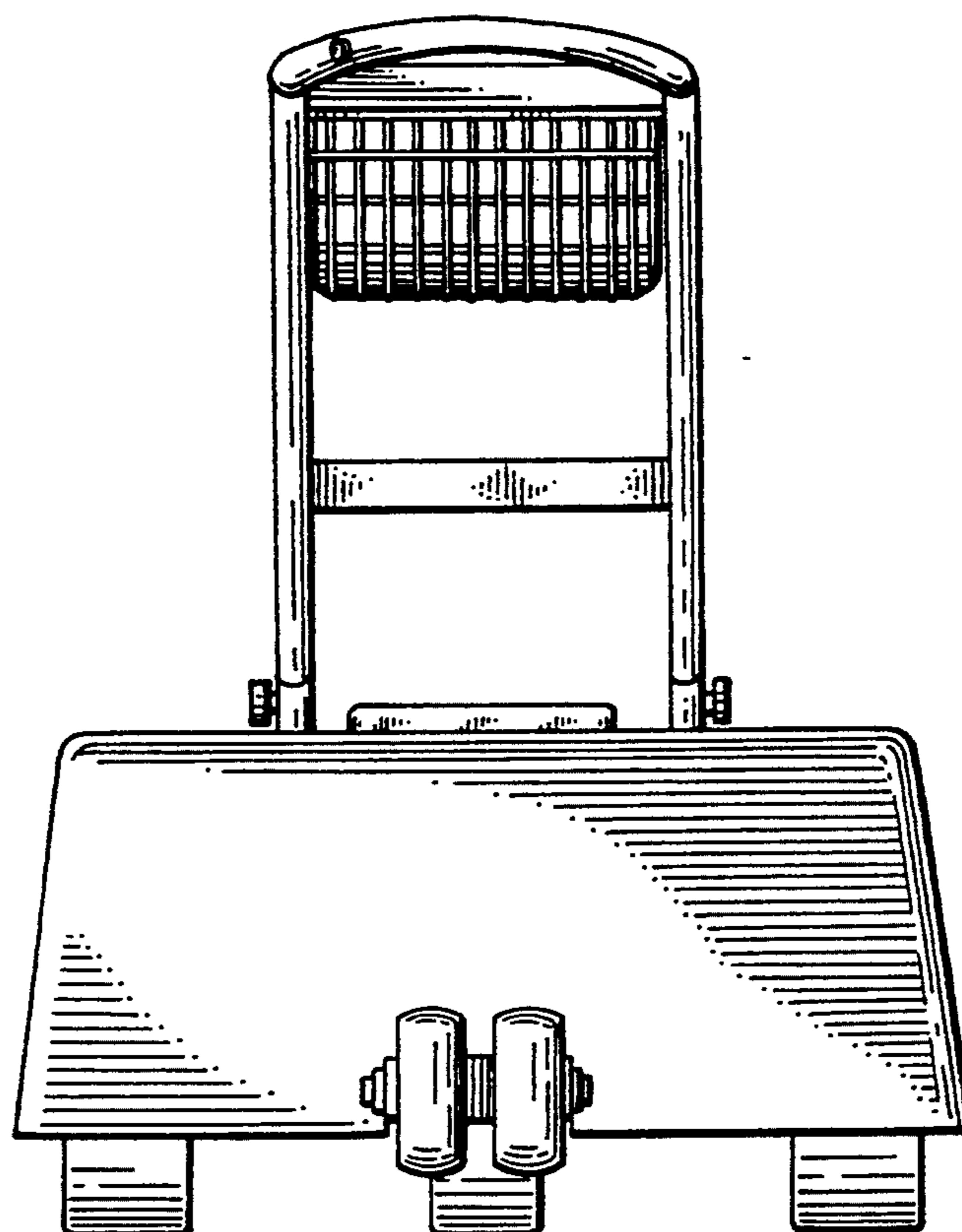

FIG. 4



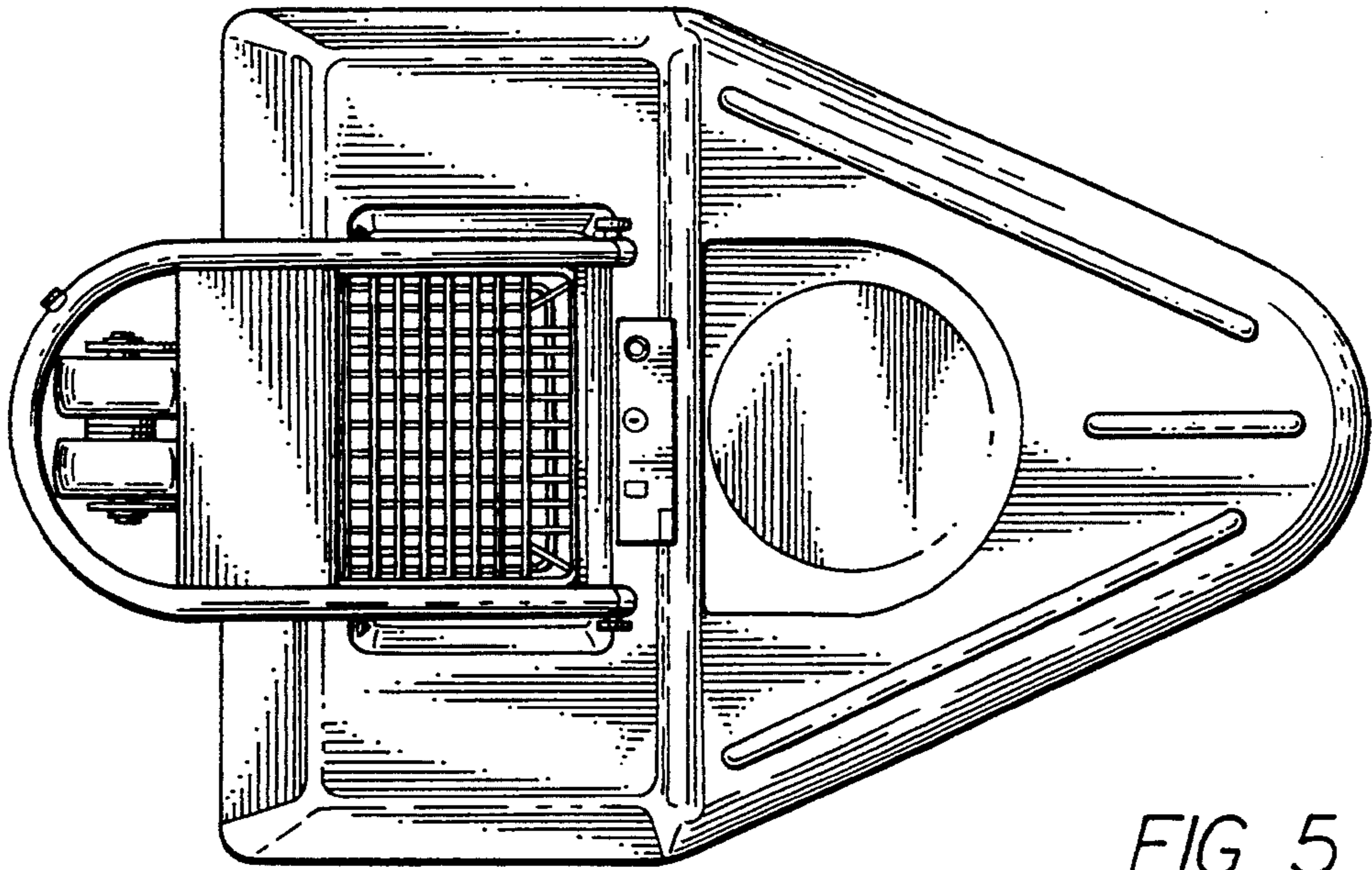

FIG. 5

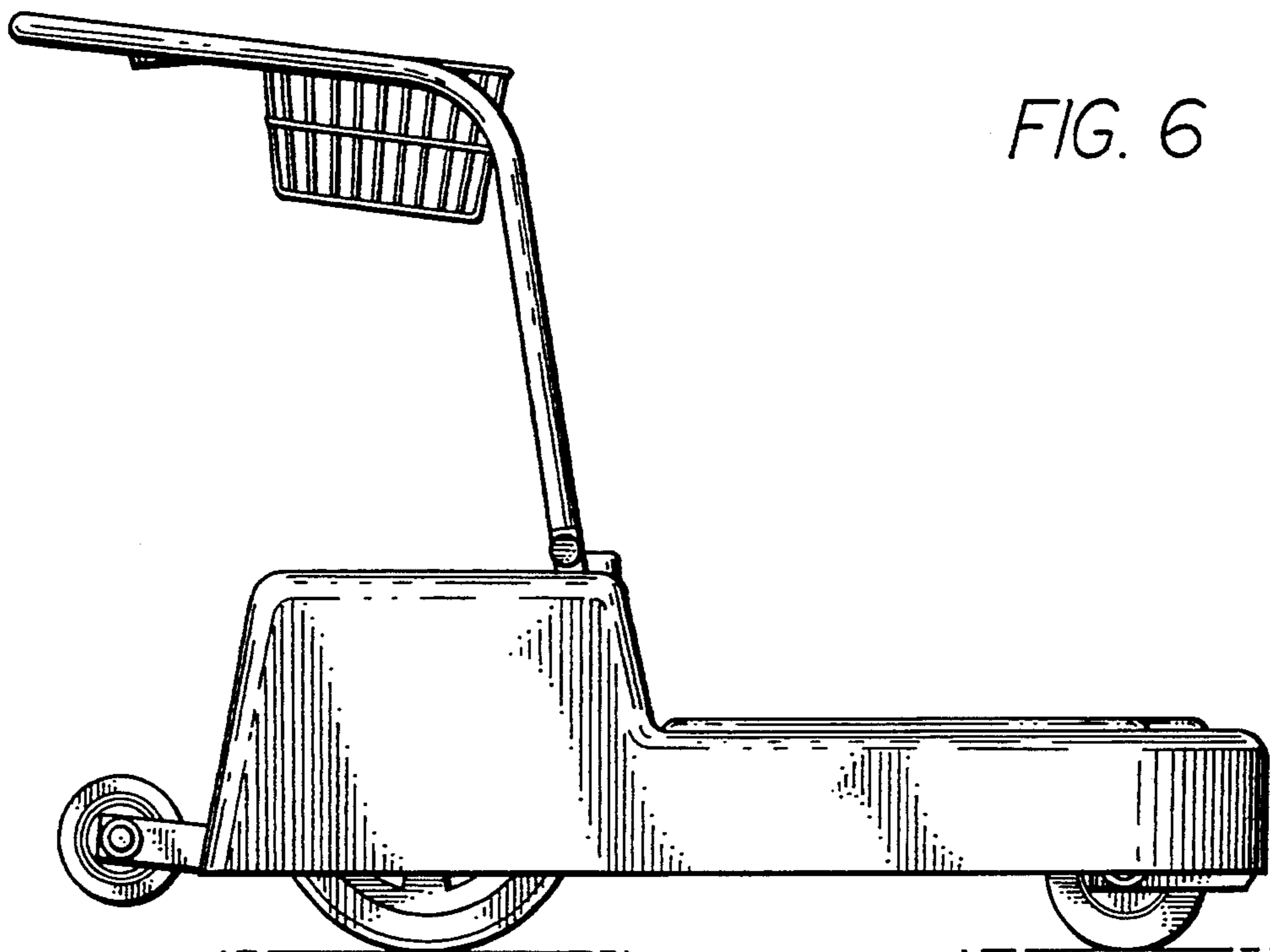

FIG. 6

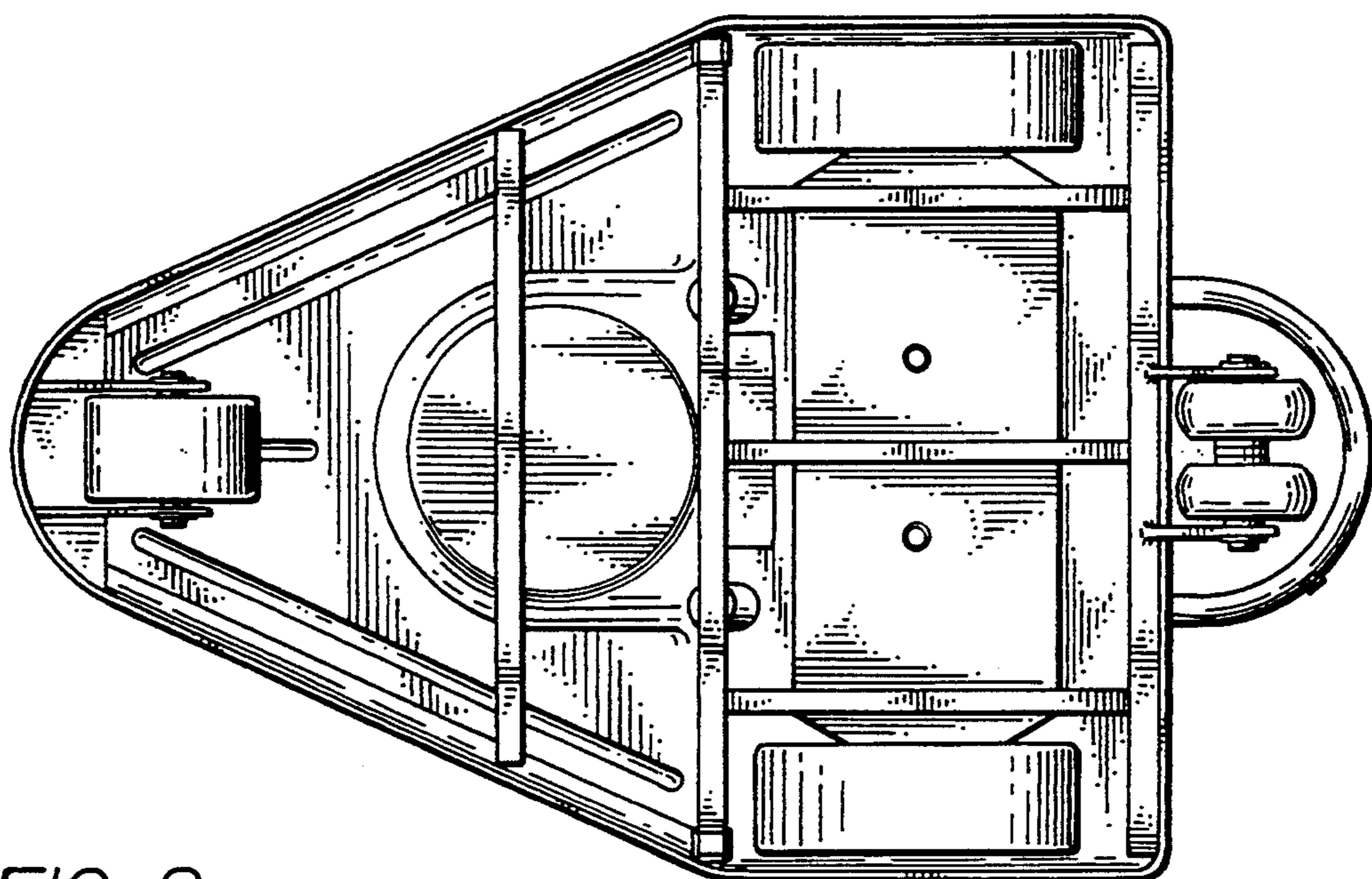
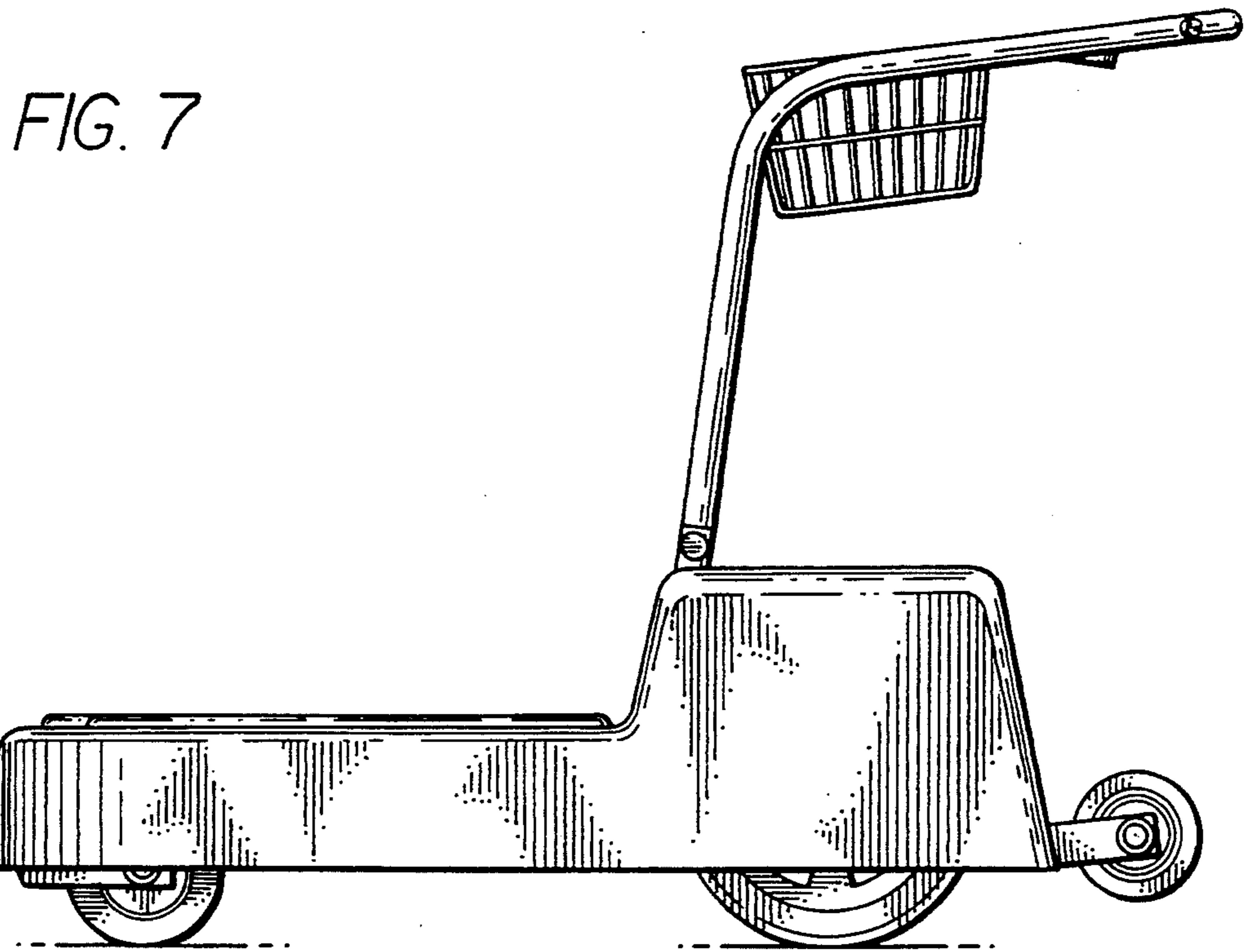

FIG. 8