



US00D353565S

# United States Patent [19]

[11] Patent Number: Des. 353,565

Kassai

[45] Date of Patent: \*\* Dec. 20, 1994

## [54] INVALID CARRIAGE

## DESCRIPTION

[75] Inventor: **Kenzou Kassai**, Osaka, Japan  
 [73] Assignee: **Aprica Kassai Kabushikikaisha**,  
Osaka, Japan  
 [\*\*] Term: **14 Years**  
 [21] Appl. No.: **7,029**  
 [22] Filed: **Apr. 13, 1993**  
 [30] Foreign Application Priority Data  
 Dec. 28, 1992 [JP] Japan ..... 4-38855  
 [52] U.S. Cl. .... **D12/128; D12/132**  
 [58] Field of Search ..... 5/81.1, 611, 612, 600,  
5/620; D12/128, 132; D24/190

FIG. 1 is a front view of an invalid carriage showing my new design;  
 FIG. 2 is a rear view thereof;  
 FIG. 3 is a top view thereof;  
 FIG. 4 is a bottom view thereof;  
 FIG. 5 is a left side view thereof;  
 FIG. 6 is a right side view thereof;  
 FIG. 7 is a perspective view thereof;  
 FIG. 8 is a perspective view thereof, showing the rectangular frame in a lowered condition;  
 FIG. 9 is a perspective view thereof showing the invalid carriage positioned on rails, the broken lines of rails are not part of the claimed design;  
 FIG. 10 is a perspective view thereof showing a bed combined with the carriage resting on rails, the broken line illustration of rails and bed are not part of the claimed design;  
 FIG. 11 is a perspective view thereof showing the carriage in use in which an invalid is raised in a prone position from the bed, the broken lines are for illustrative purposes only;  
 FIG. 12 is a perspective view thereof showing another use in which an invalid is suspended by a hammock in a sitting state, the broken lines are for illustrative purposes only; and,  
 FIG. 13 is a perspective view thereof showing another use in which an invalid is performing a walking exercise.

## [56] References Cited

### U.S. PATENT DOCUMENTS

3,099,020	7/1963	Garfield et al. ....	5/620
4,451,944	6/1984	James .....	5/612
4,939,801	7/1990	Schaal et al. ....	5/61
5,173,978	12/1992	Kassai et al. ....	5/600
5,181,289	1/1993	Kassai .....	5/81.1

Primary Examiner—**Kay H. Chin**  
 Attorney, Agent, or Firm—**W. G. Fasse; W. F. Fasse**

## [57] CLAIM

The ornamental design for an invalid carriage, as shown and described.

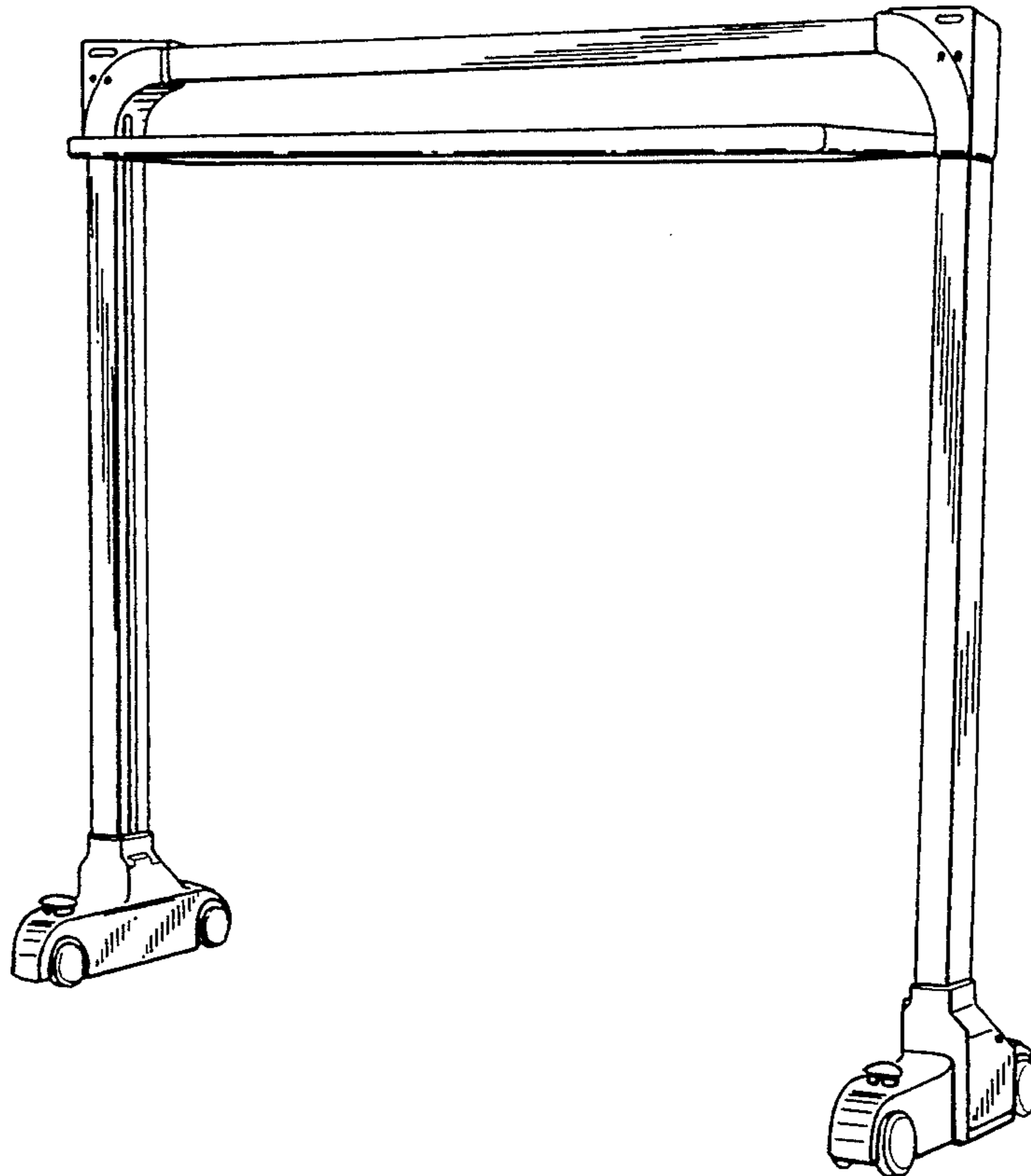

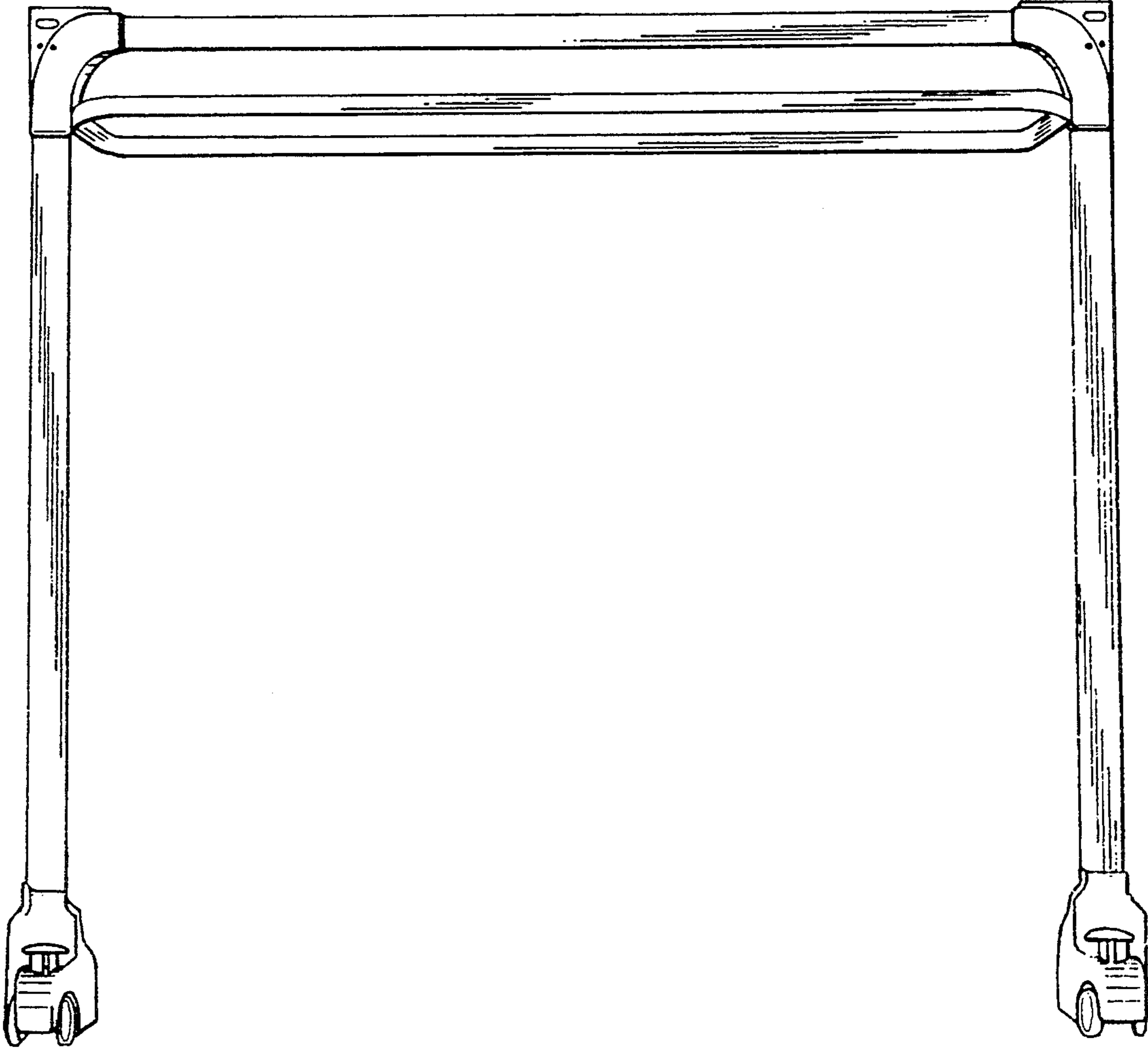
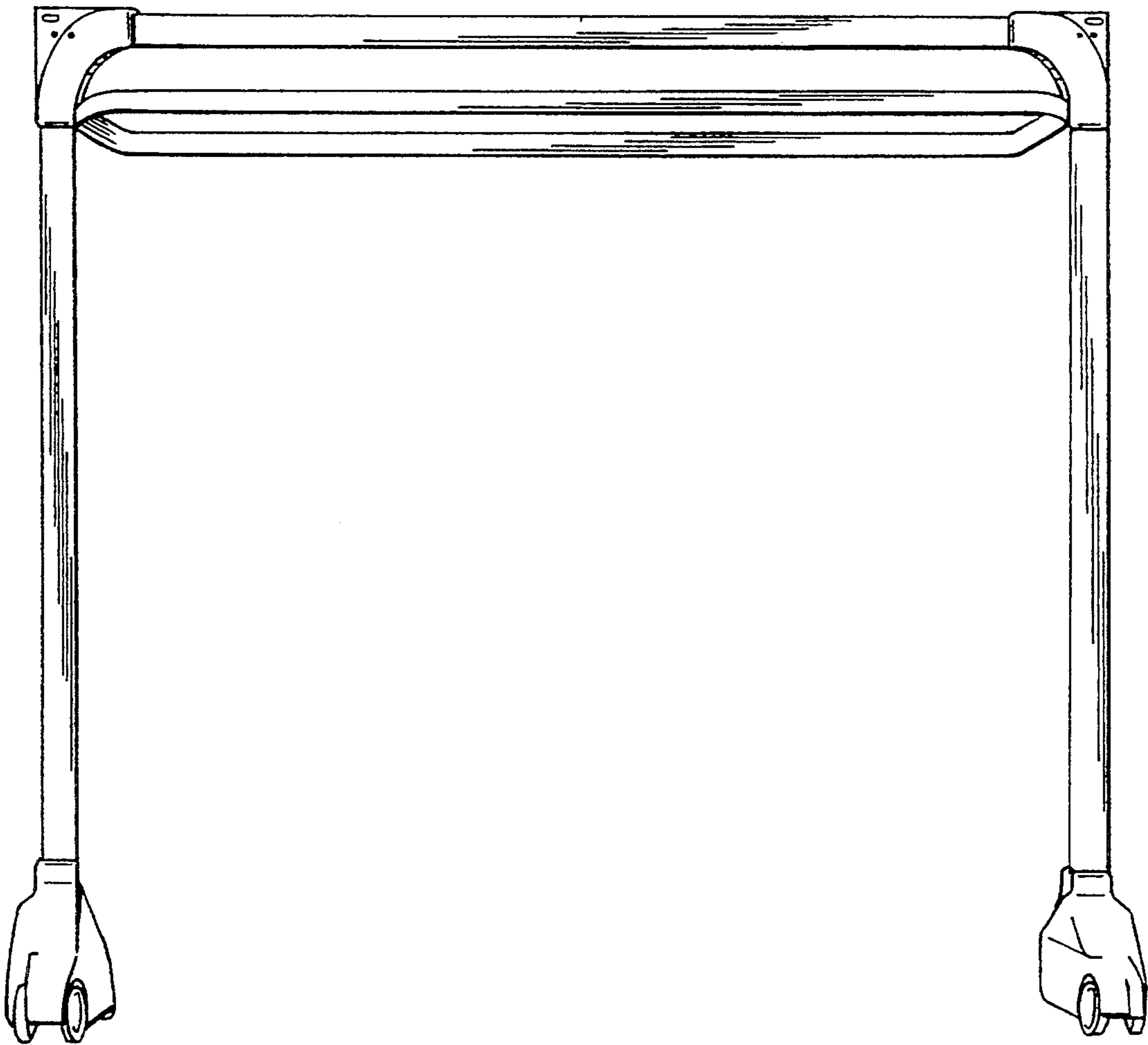

FIG. 1

FIG. 2



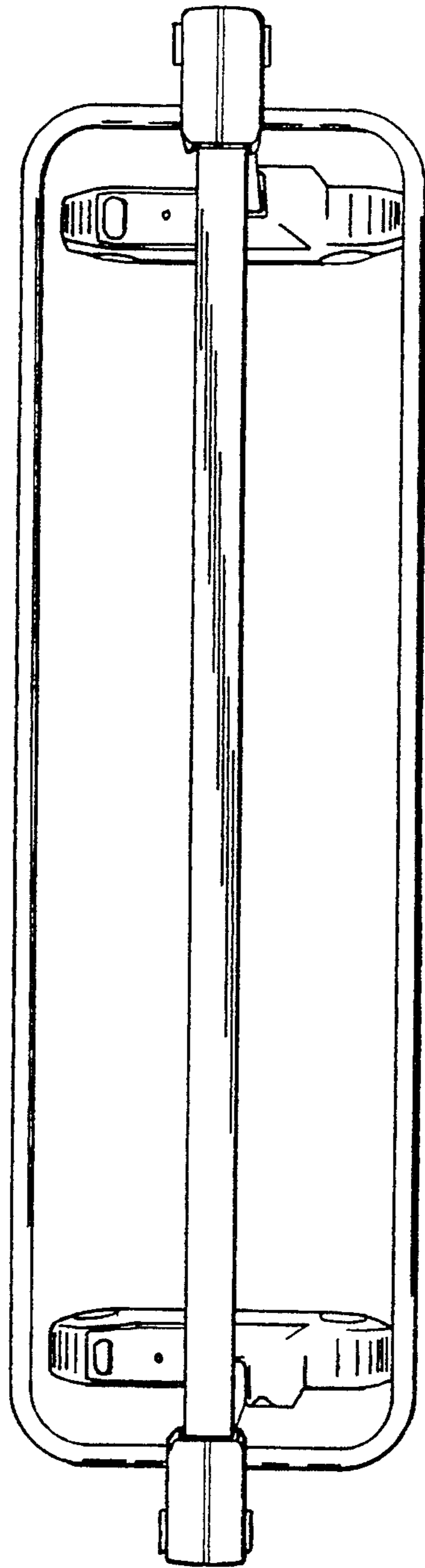

FIG. 3

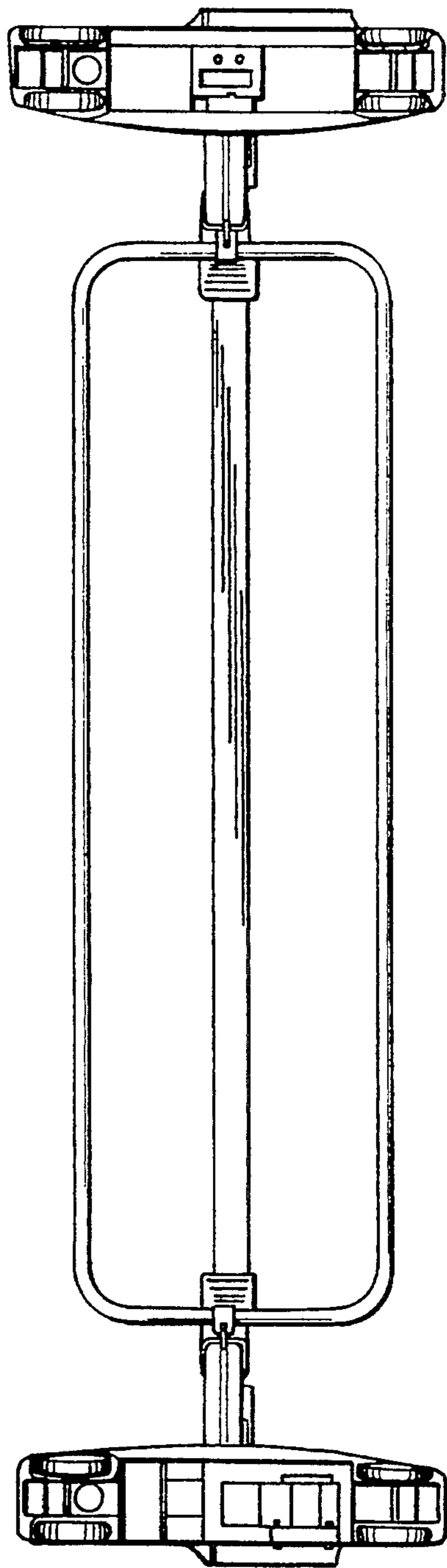

FIG. 4

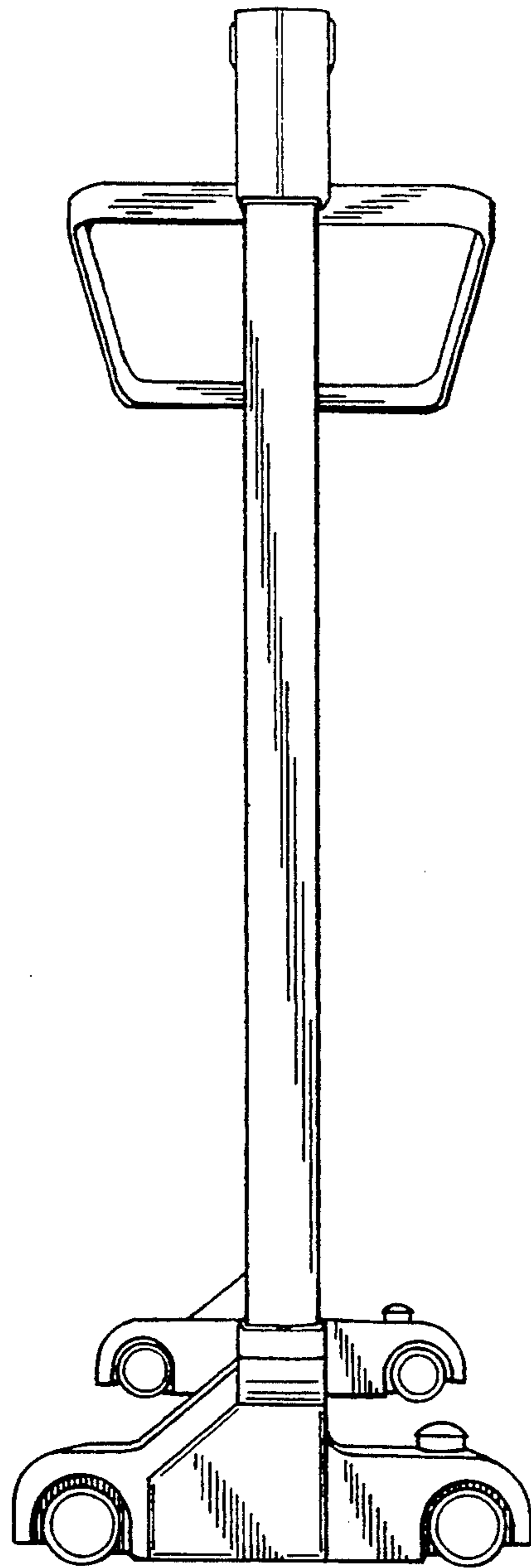

FIG. 5

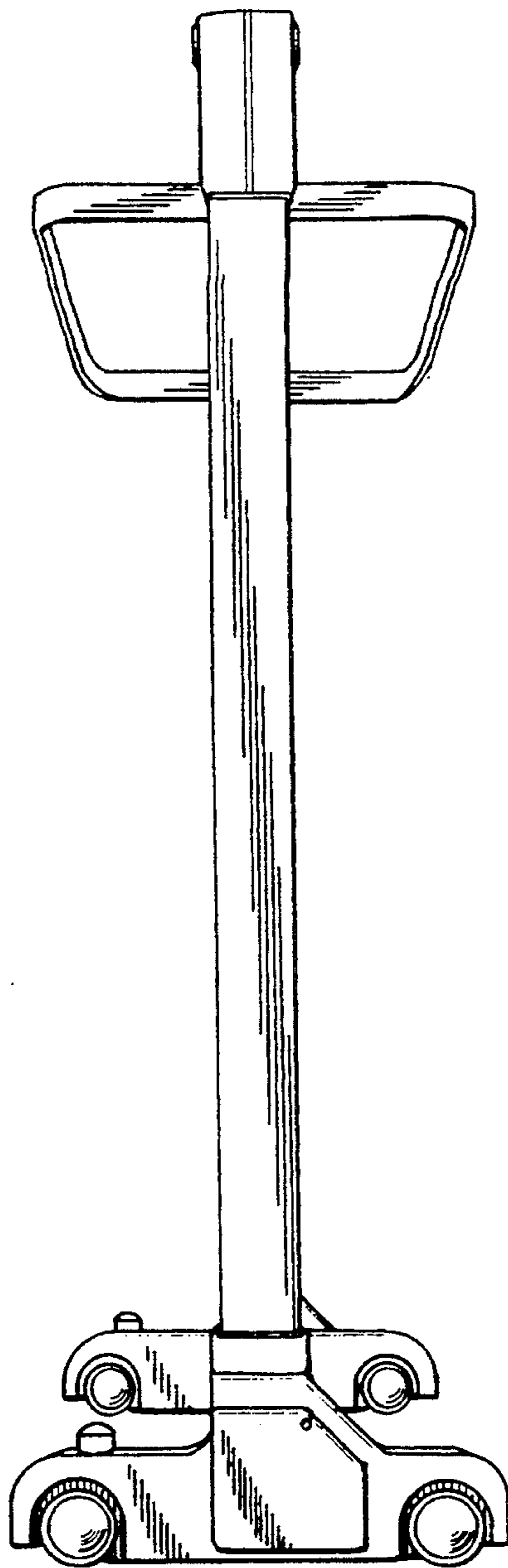

FIG. 6

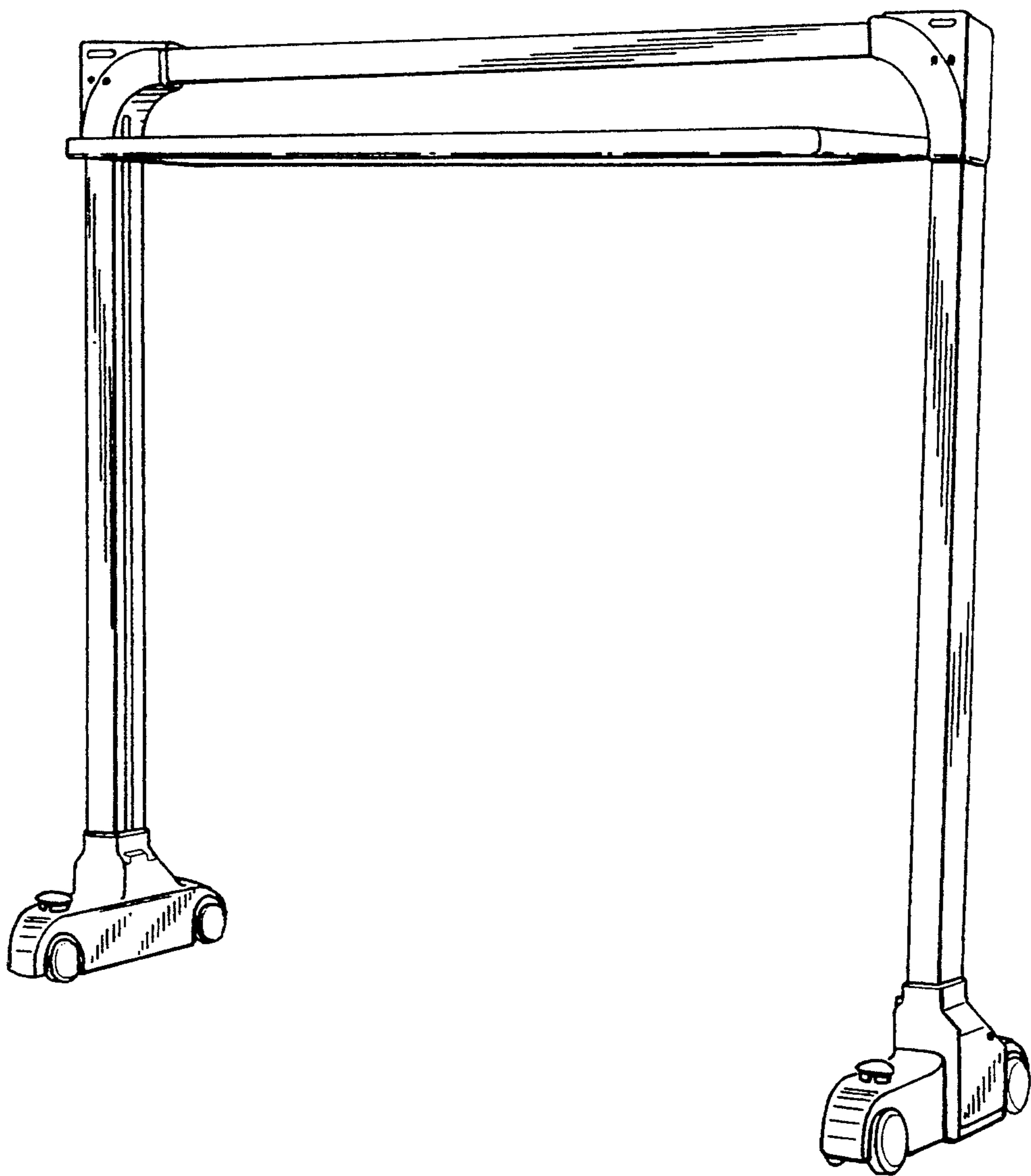

FIG. 7



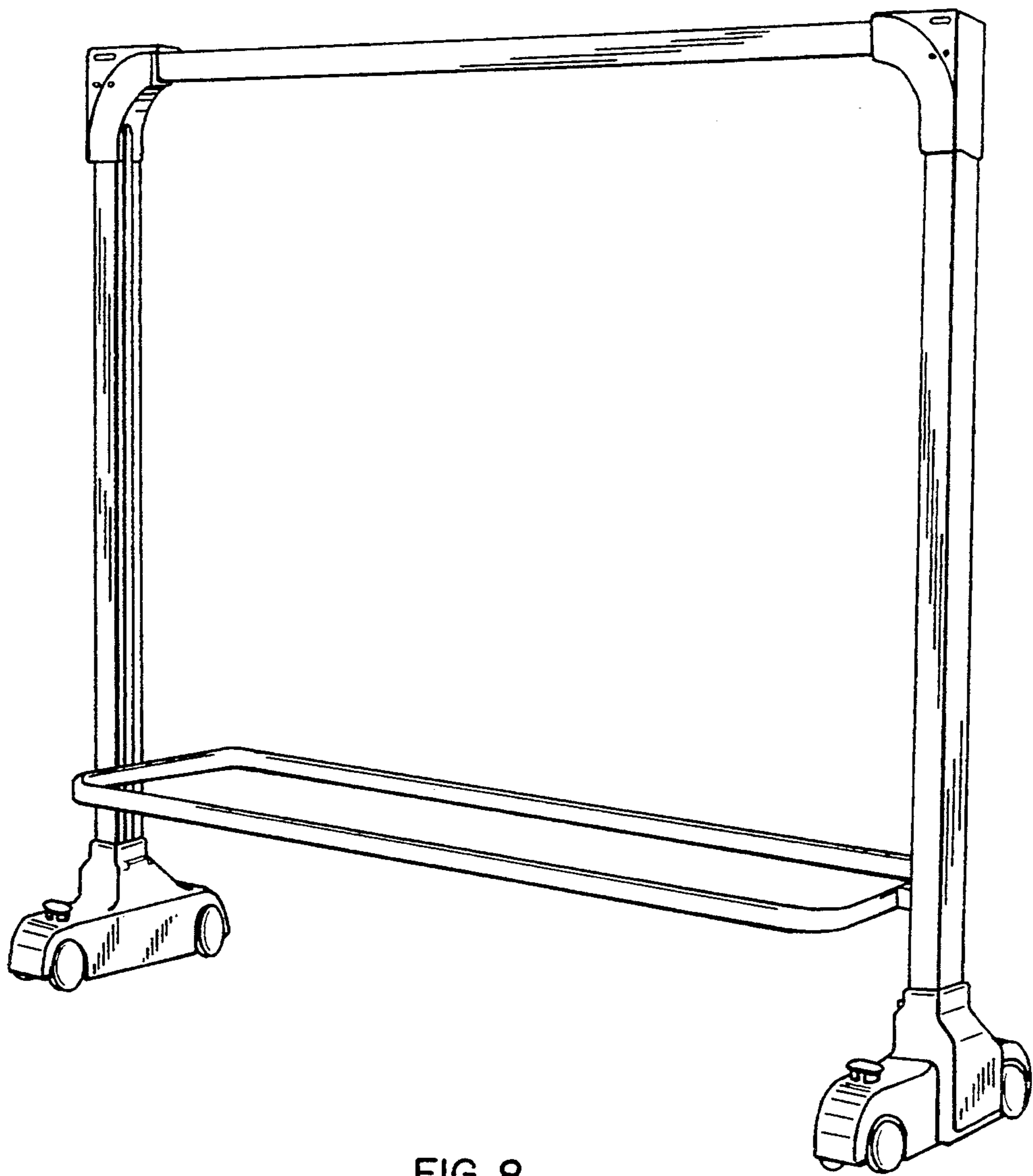

FIG. 8

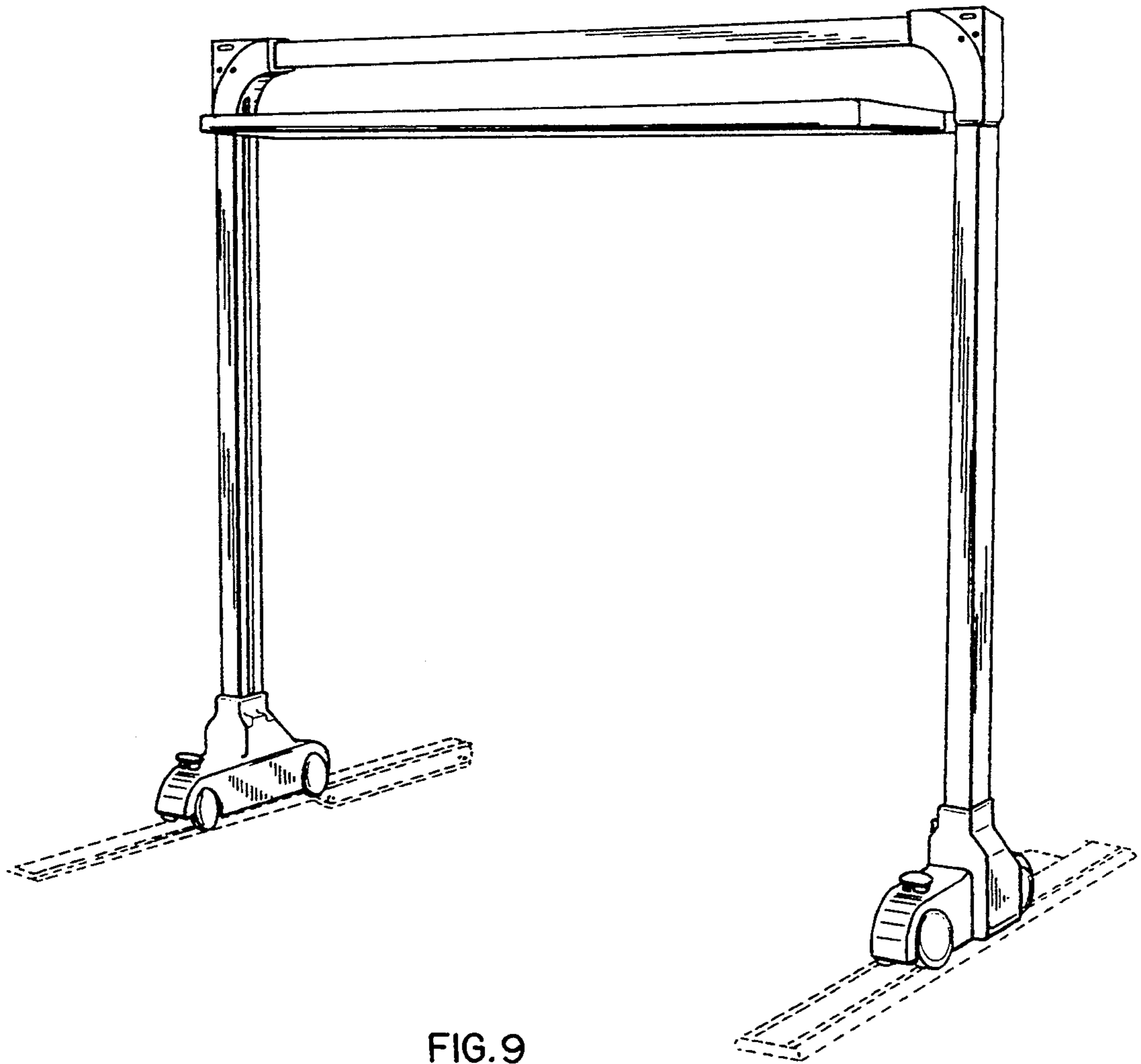

FIG. 9

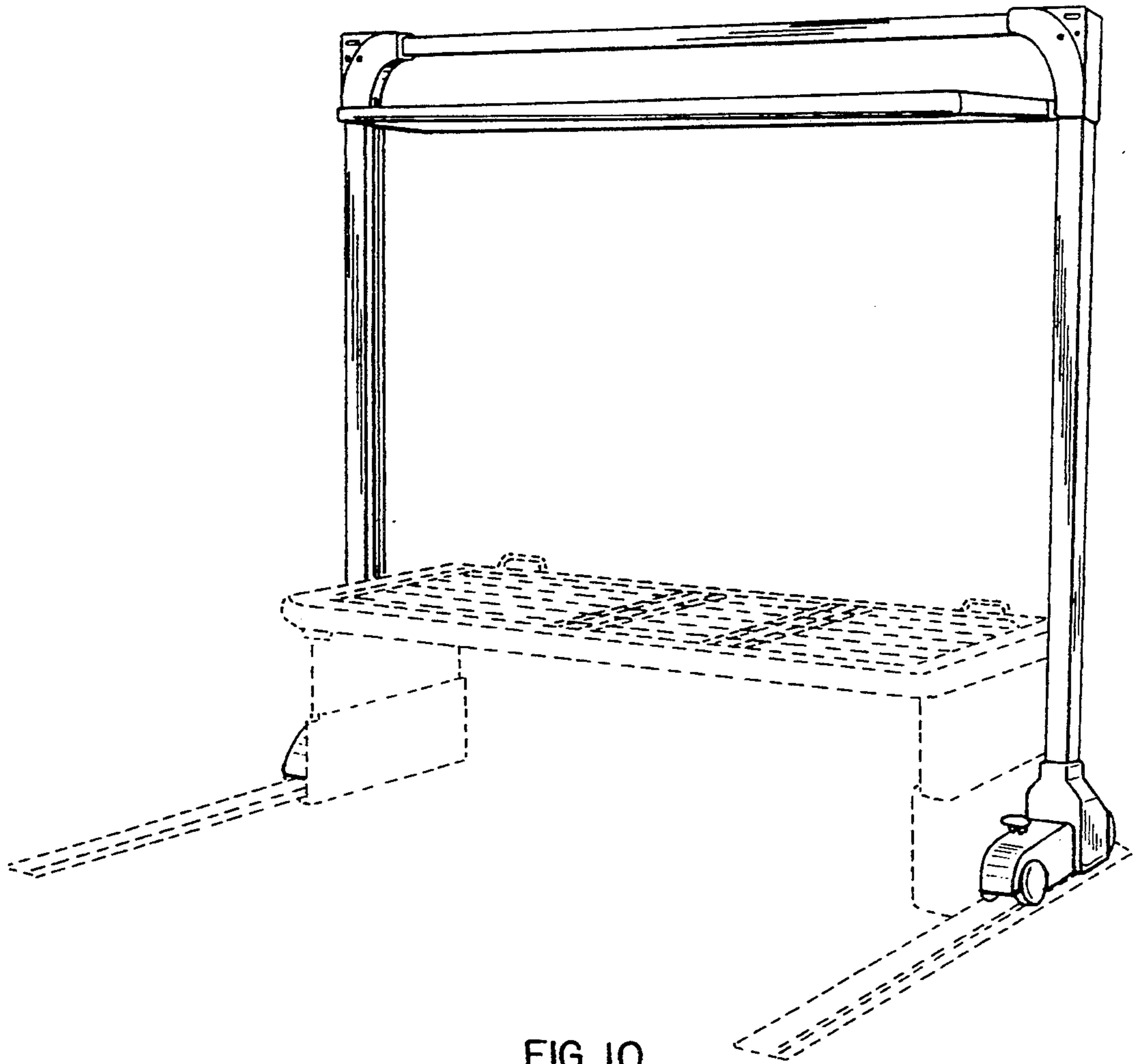

FIG. 10

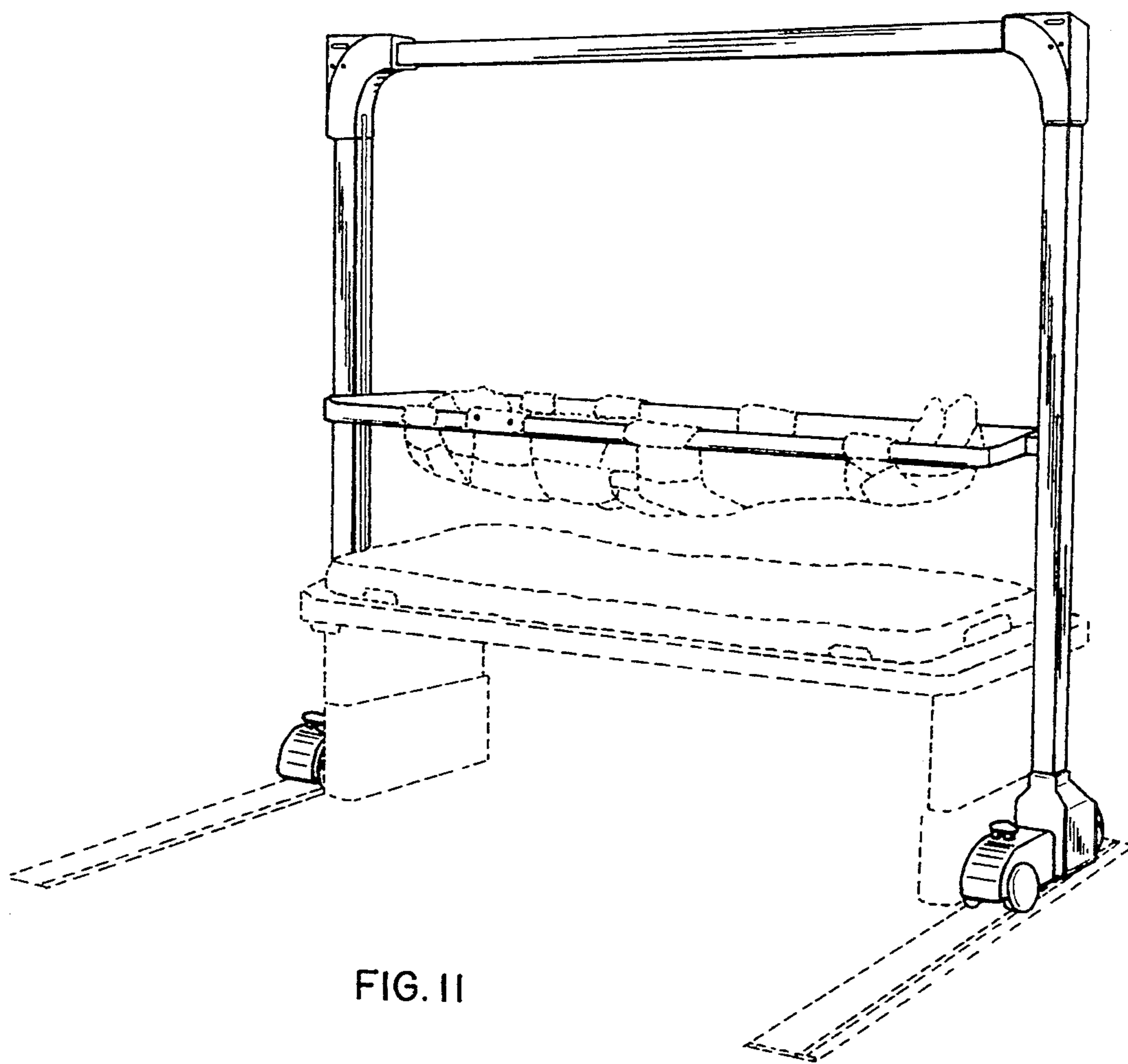

FIG. II

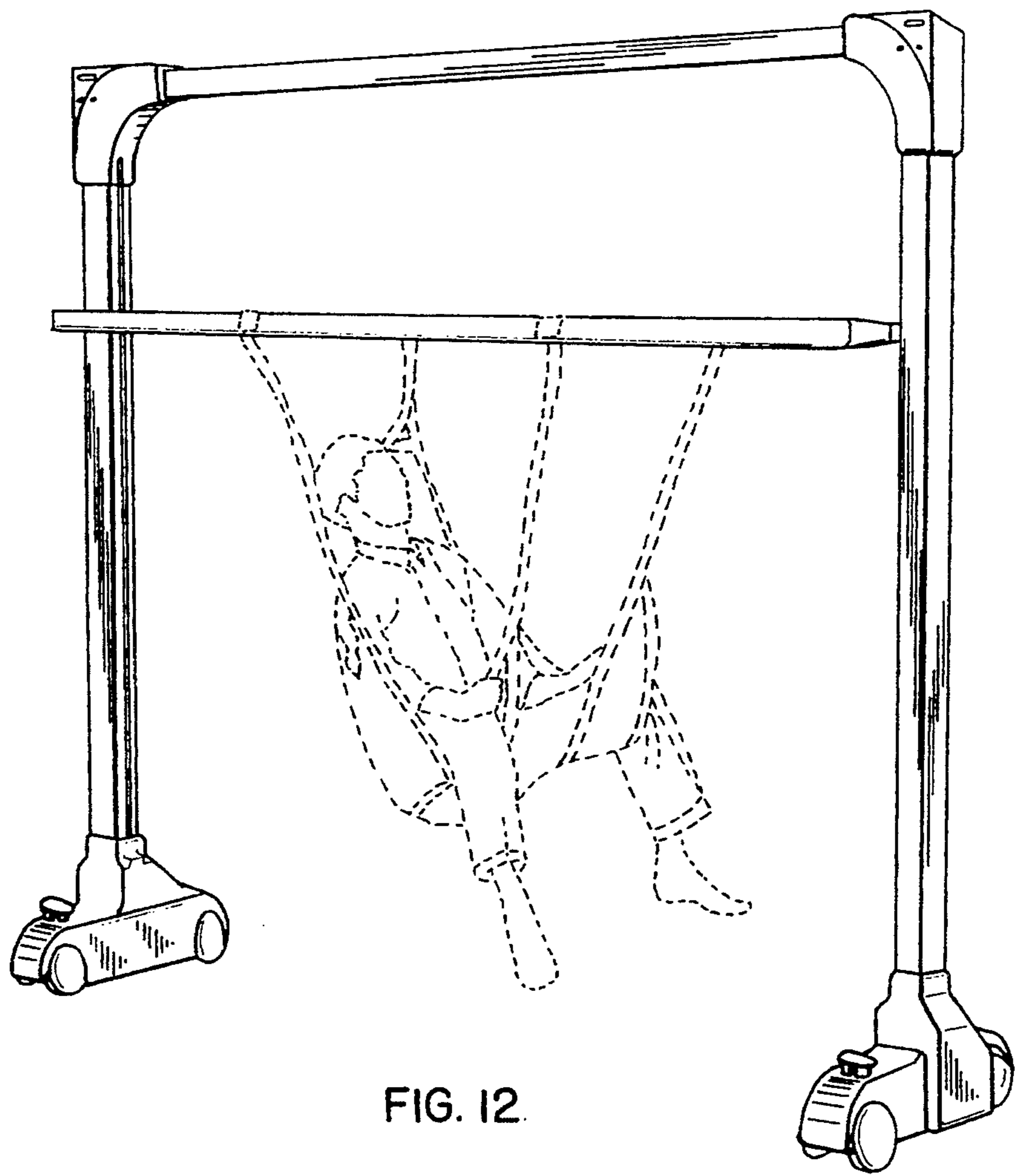

FIG. 12.

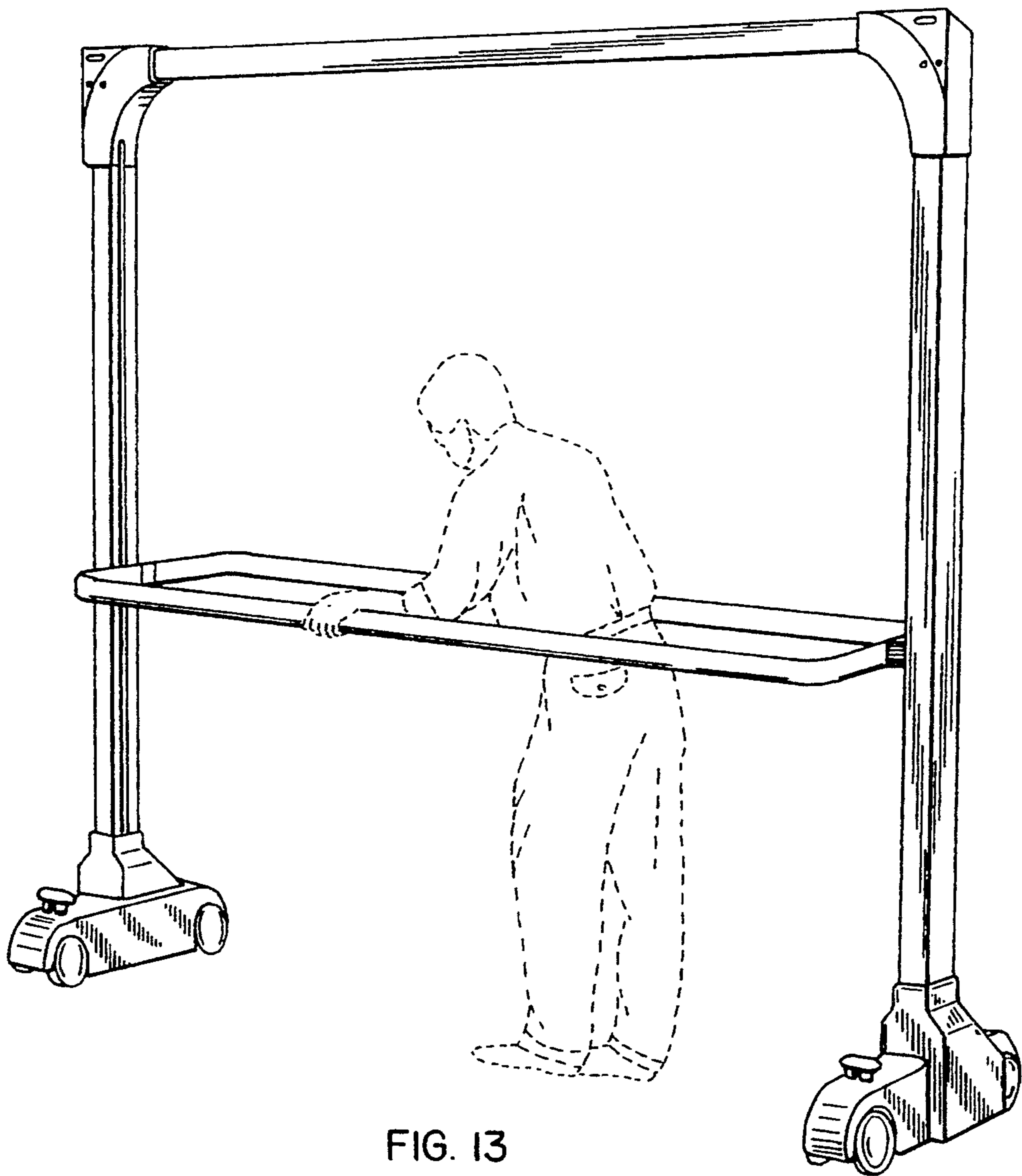

FIG. 13