



US00D353505S

# United States Patent [19]

[11] Patent Number: **Des. 353,505**

Rea

[45] Date of Patent: **\*\* Dec. 20, 1994**

[54] GARAGE MAT

[56] References Cited

[76] Inventor: **Marty P. L. Rea**, 5 Rovers Avenue,  
Red Deer, Alberta, Canada, T4P  
3K4

### U.S. PATENT DOCUMENTS

D. 204,539	4/1966	Stata .....	D12/203
D. 242,136	11/1976	Matlock .....	D12/203 X
D. 339,560	9/1993	Byrd .....	D12/203
4,980,936	1/1991	Frickland et al. ....	5/420
5,154,961	5/1991	Reuben .....	D12/203 X

[\*\*] Term: **14 Years**

*Primary Examiner*—Wallace R. Burke  
*Assistant Examiner*—Monica A. Hannon  
*Attorney, Agent, or Firm*—Bauer & Schaffer

[21] Appl. No.: **877,585**

### [57] CLAIM

[22] Filed: **May 1, 1992**

The ornamental design for a garage mat, as shown and described.

### [30] Foreign Application Priority Data

### DESCRIPTION

Mar. 6, 1992 [CA] Canada ..... 06-03-92-13

FIG. 1 is a perspective view of a garage mat showing my new design;

[52] U.S. Cl. .... **D6/582; D6/592**

FIG. 2 is a top plan view in enlarged scale;

[58] Field of Search ..... **D6/582; 4/581, 582, 4/583; 5/417, 418, 419, 420, 448, 464; 15/215, 216, 217; 188/32; D12/203**

FIG. 3 is a side elevation of the design;

FIG. 4 is a bottom plan; and,

FIGS. 5 and 6 are end elevations.

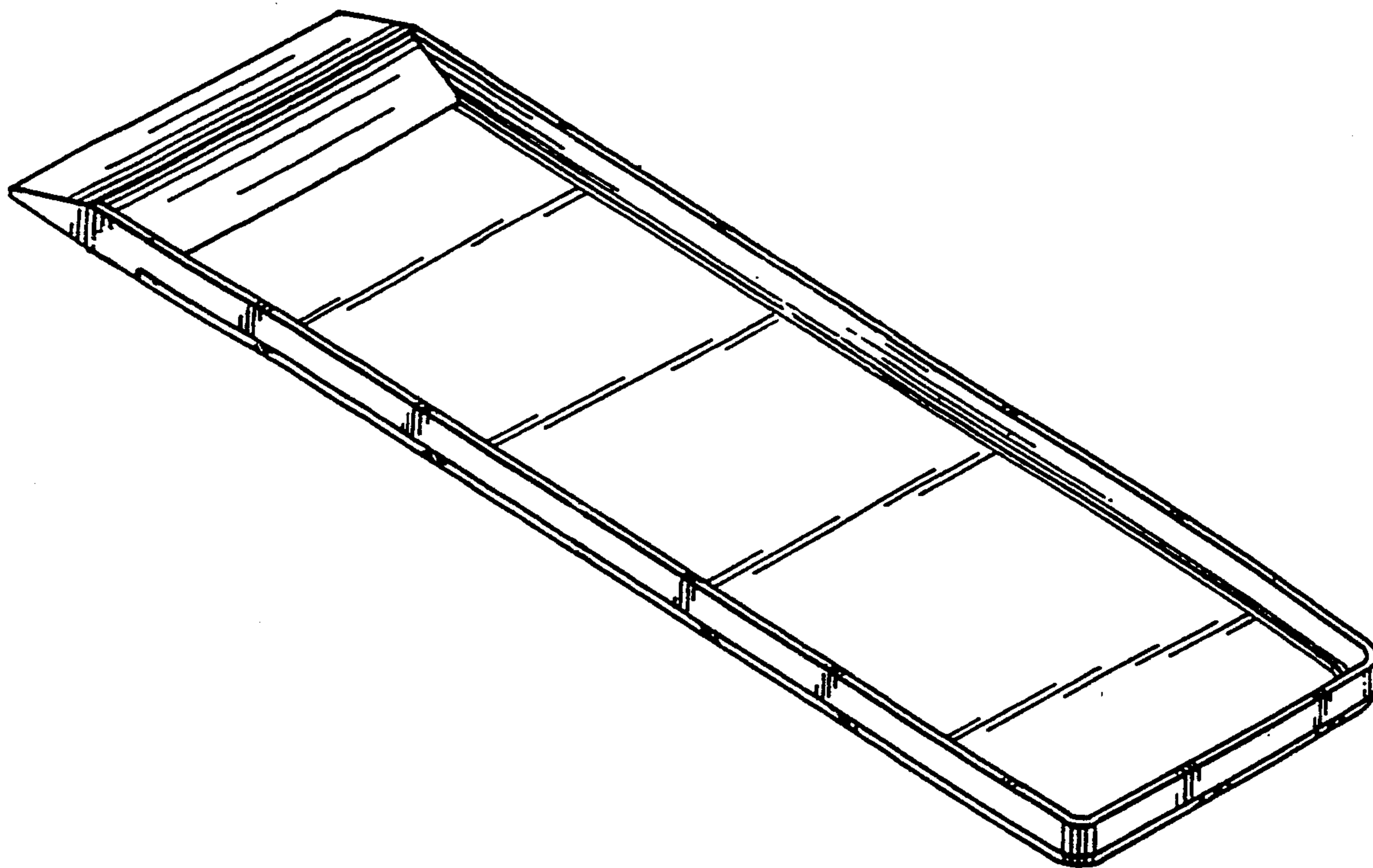

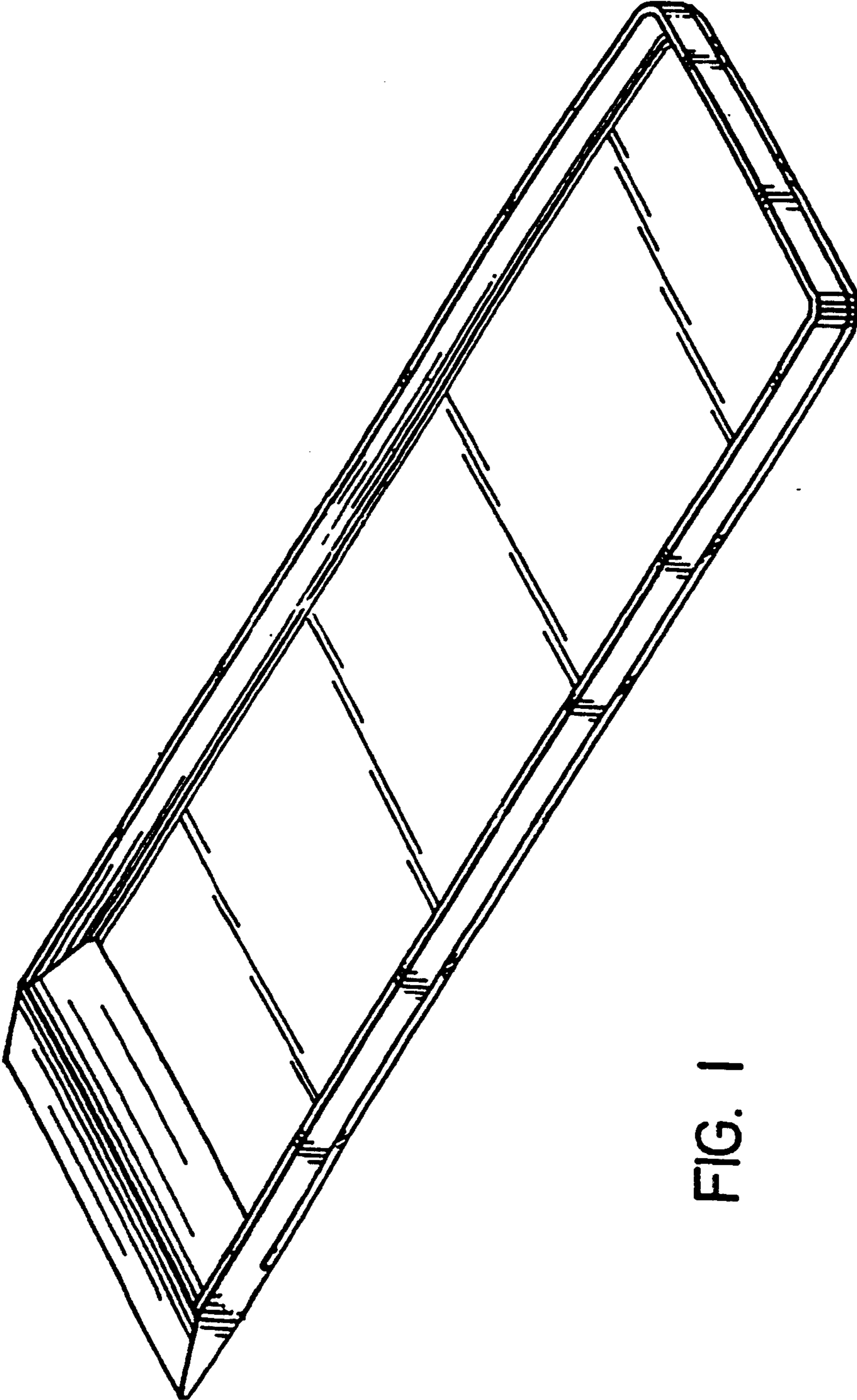

FIG. 1

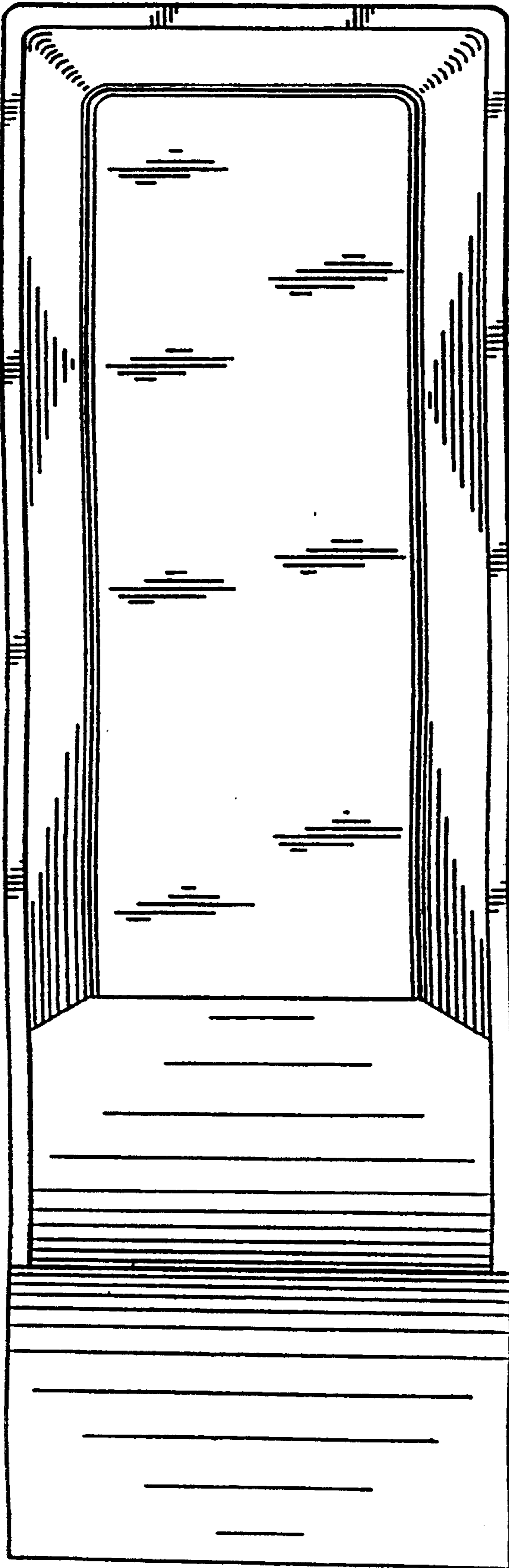

FIG. 2

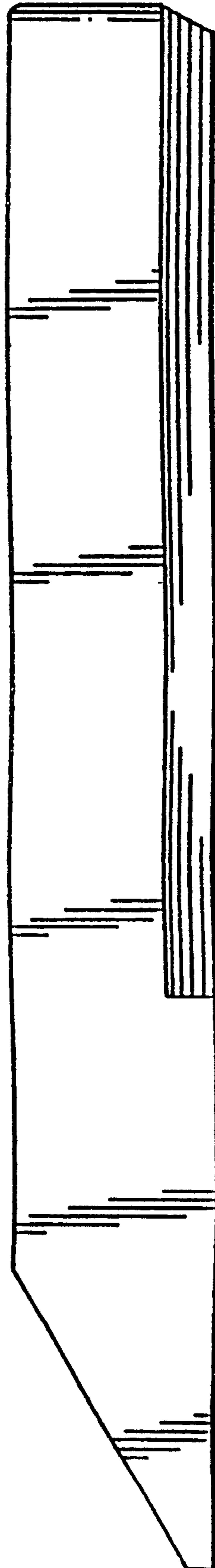

FIG. 3

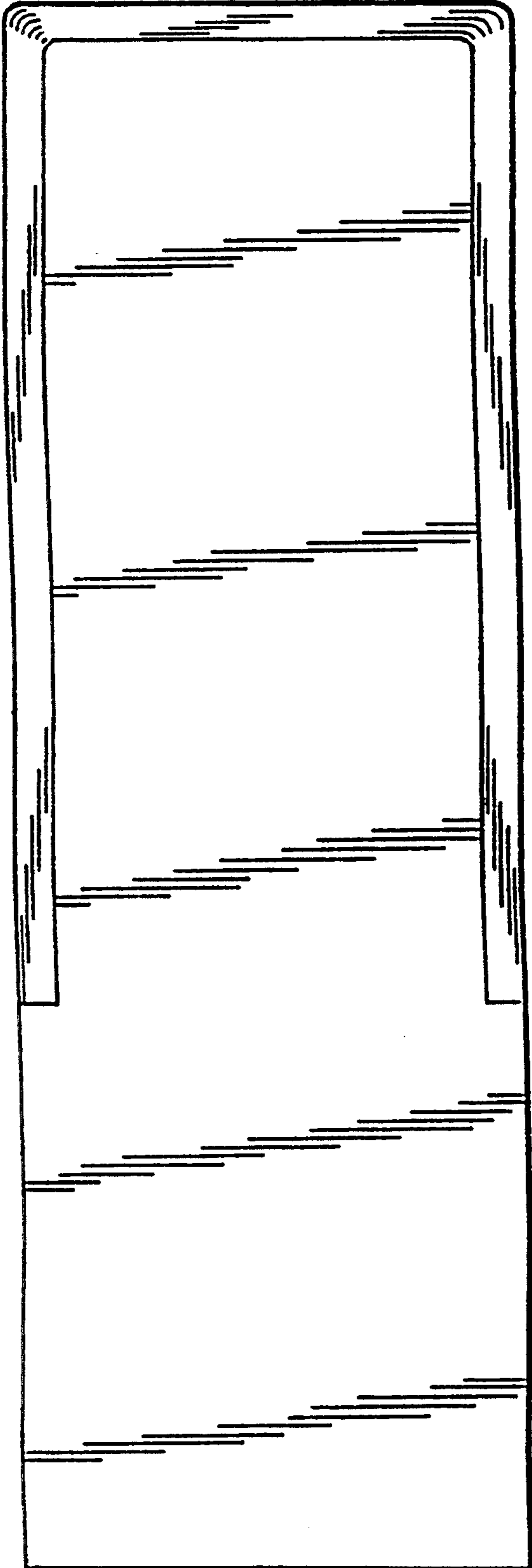

FIG. 4

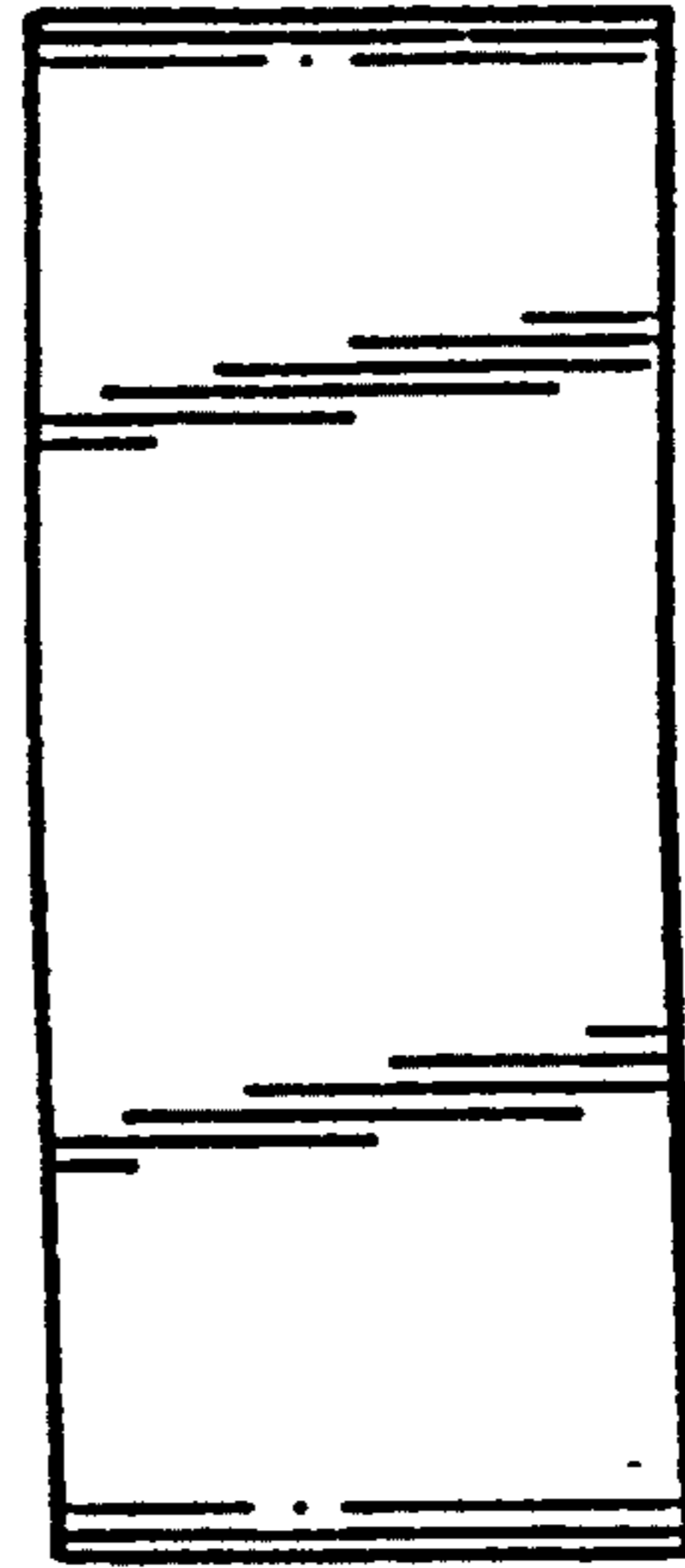

FIG. 6

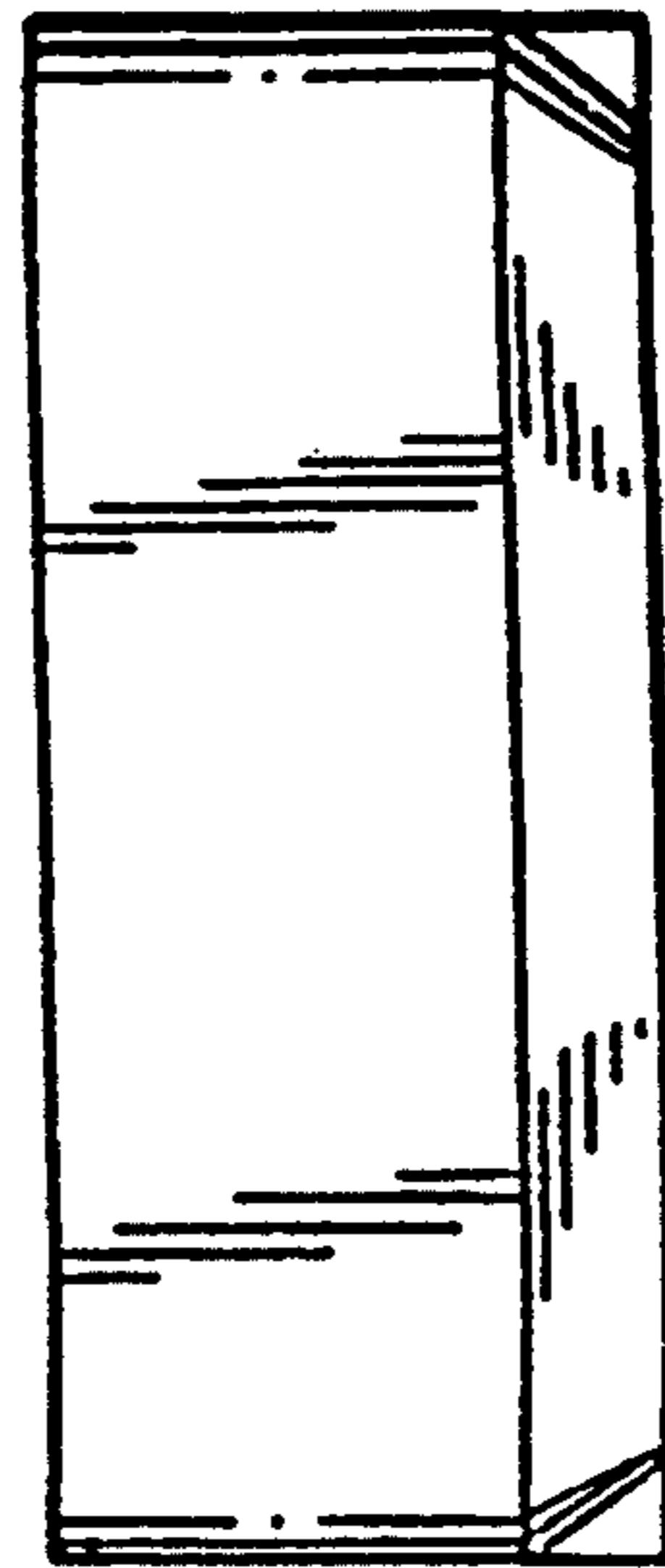

FIG. 5