



US00D353500S

# United States Patent [19]

[11] Patent Number: **Des. 353,500**

Remmers

[45] Date of Patent: **\*\* Dec. 20, 1994**

[54] **GLIDE RUNNER SUPPORT**

5,105,953 4/1992 Finnegan .

[75] Inventor: **Lee E. Remmers, Ocala, Fla.**

5,275,483 1/1994 Rasmussen ..... 312/334.27 X

[73] Assignee: **Vermont American Corporation, Louisville, Ky.**

*Primary Examiner*—Janice E. Seeger  
*Attorney, Agent, or Firm*—Middleton & Reutlinger

[\*\*] Term: **14 Years**

[57] **CLAIM**

[21] Appl. No.: **7,846**

The ornamental design for a glide runner support, as shown and described.

[22] Filed: **Apr. 30, 1993**

**DESCRIPTION**

[52] U.S. Cl. .... **D6/510**

[58] Field of Search ..... D6/491, 509-511;  
312/339, 350, 334.27, 334.41; 211/183, 126

FIG. 1 is a perspective view of a glide runner support, showing my new design, the broken lines are for environmental purposes only and form no part of the claimed design;

[56] **References Cited**

**U.S. PATENT DOCUMENTS**

D. 263,914	4/1982	Litchfield et al. ....	D6/510
2,711,358	6/1955	Gussack .....	312/350 X
2,758,455	8/1956	Anderson .	
2,946,458	7/1960	Du Boff et al. .	
2,971,655	2/1961	Du Boff et al. .	
3,175,697	11/1963	Kelly .	
3,328,107	6/1967	Gutner .....	312/334.27 X
3,655,063	4/1972	Landry .	
3,797,906	3/1974	Gutner .....	312/334.27
4,904,032	2/1990	Jenkins .	
4,995,682	2/1991	Gutner .	

FIG. 2 is a perspective elevational view showing the glide runner support of FIG. 1;

FIG. 3 is a outside elevational view showing the glide runner support of FIG. 1;

FIG. 4 is a top or bottom elevational view showing the glide runner support of FIG. 1;

FIG. 5 is an inside elevational view showing the glide runner support of FIG. 1;

FIG. 6 is a rear end elevational view showing the glide runner support of FIG. 1; and,

FIG. 7 is a front end elevational view showing the glide runner support of FIG. 1.

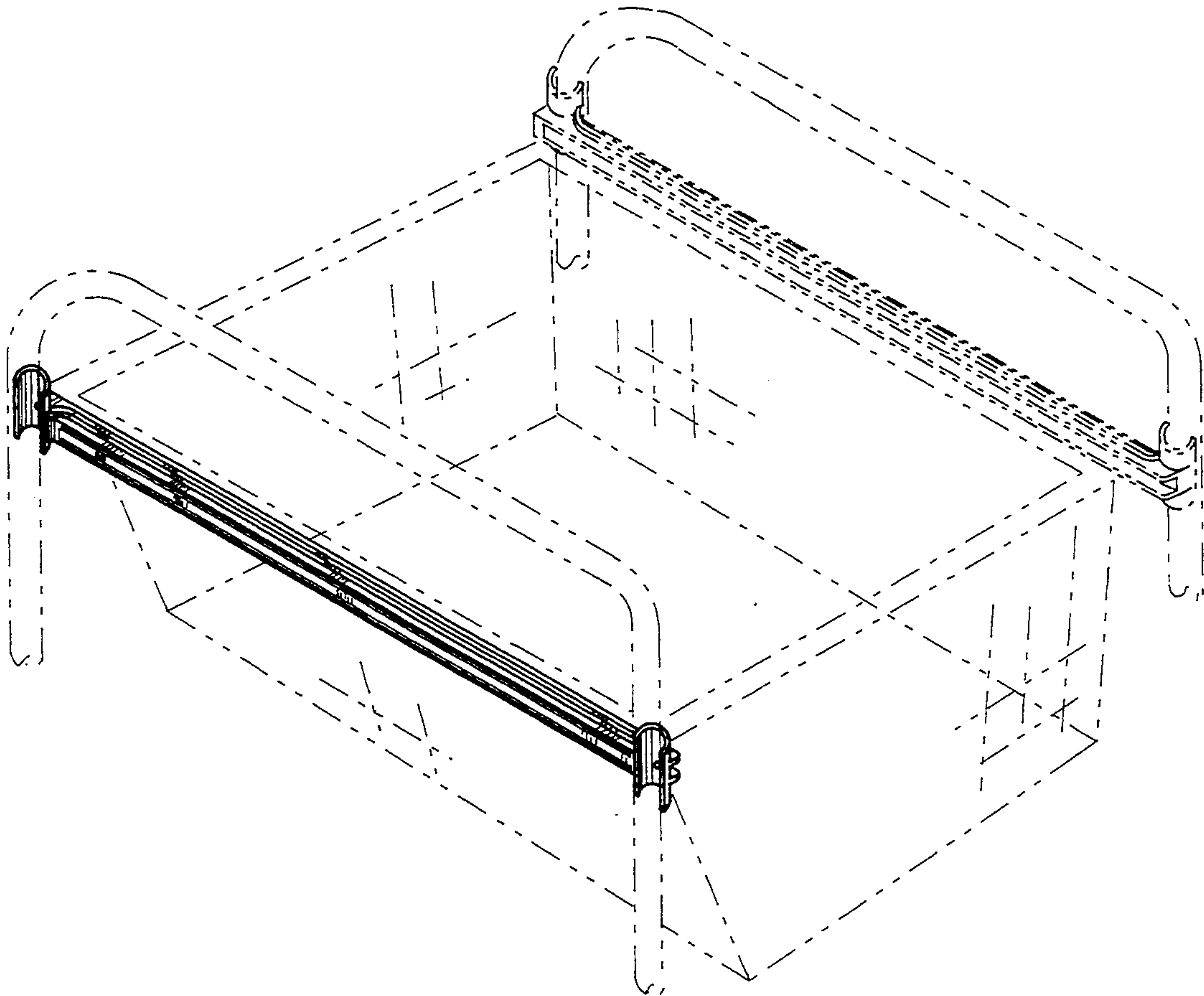

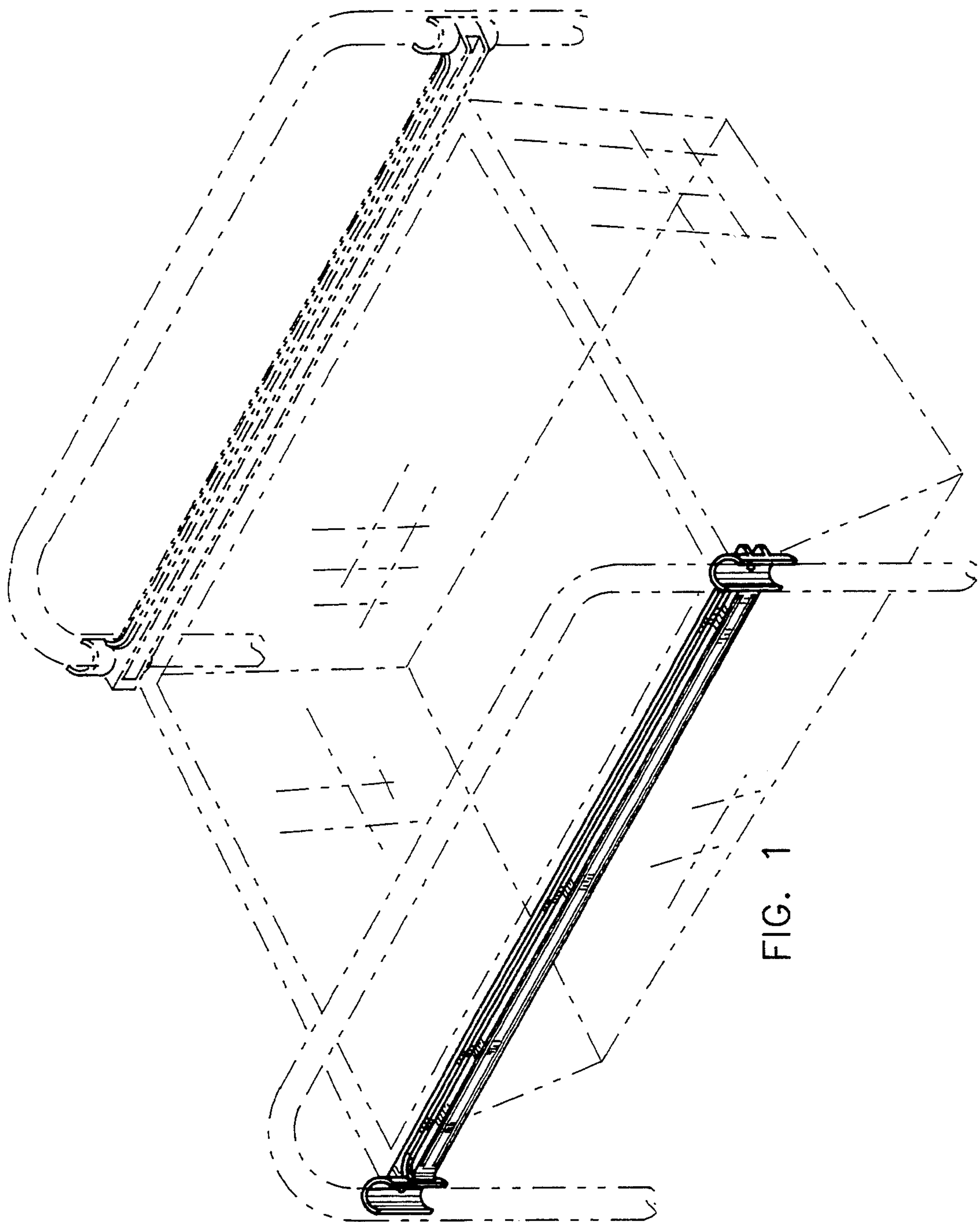

FIG. 1

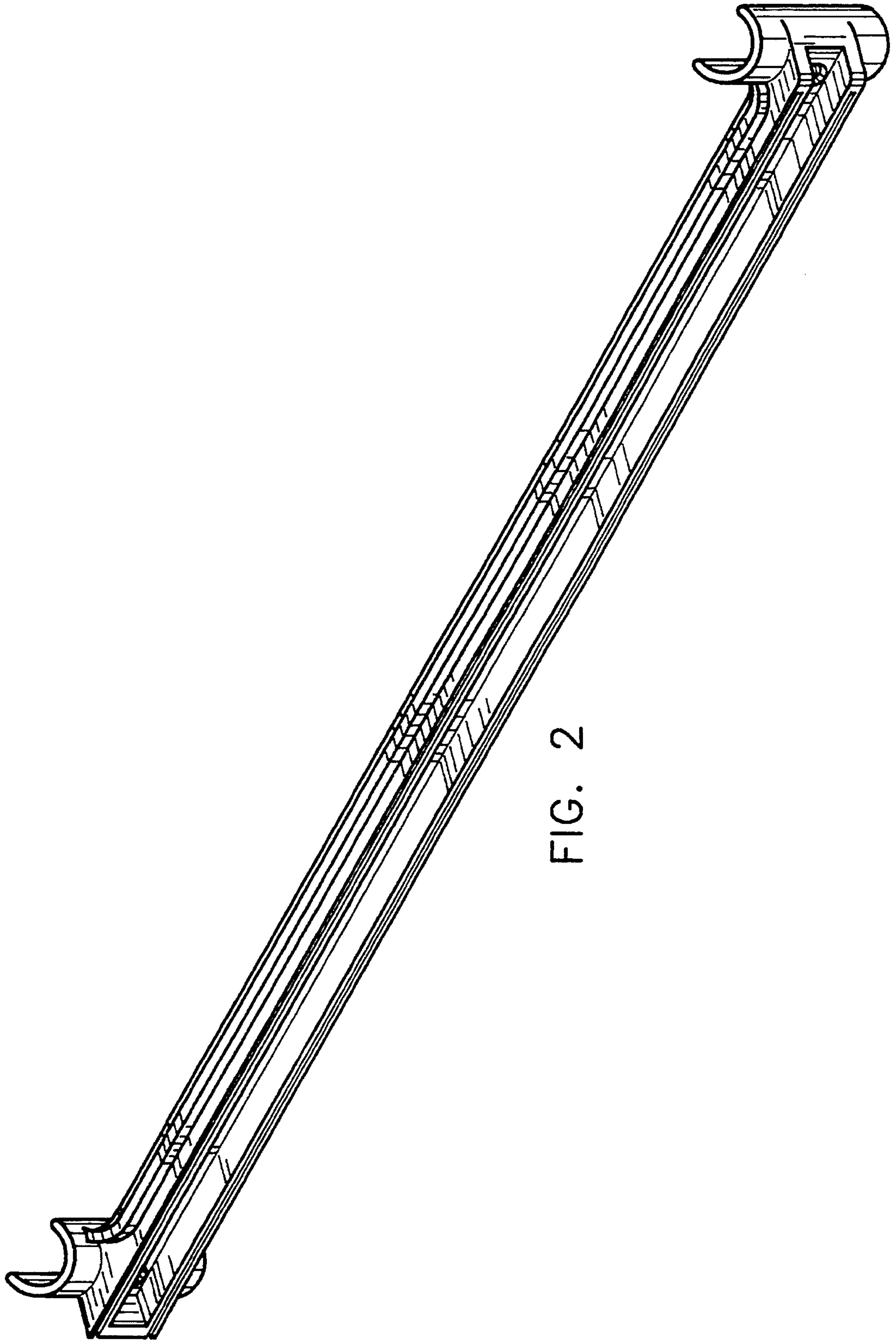

FIG. 2

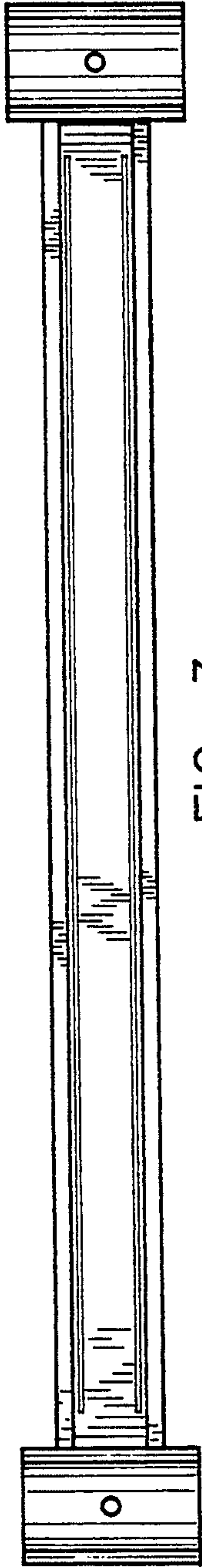

FIG. 3



FIG. 7

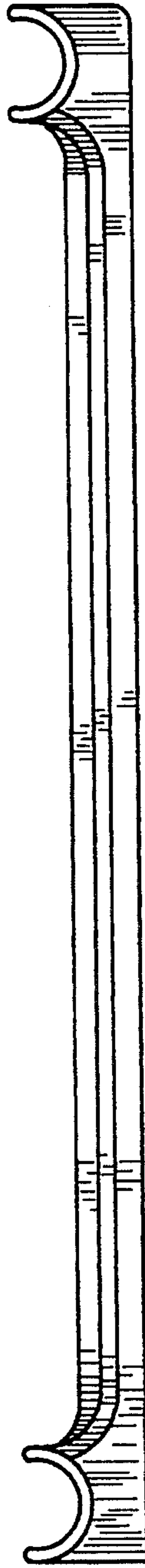

FIG. 4

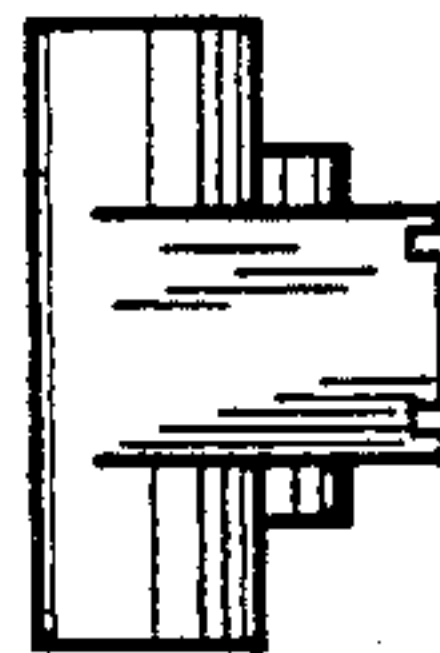

FIG. 6

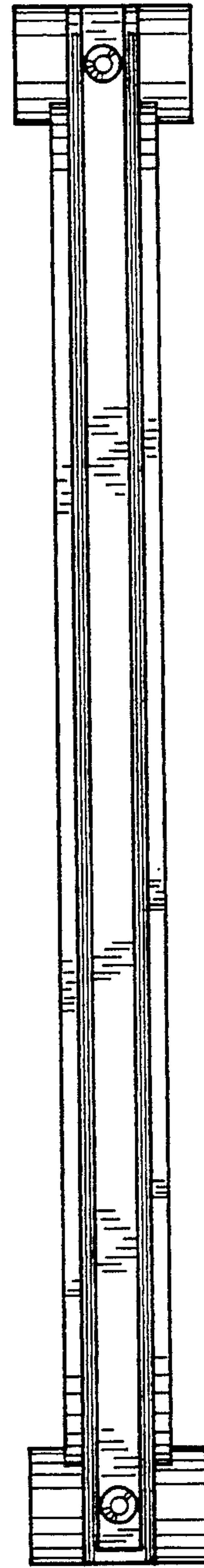

FIG. 5