



US00D353438S

United States Patent [19]

[11] Patent Number: **Des. 353,438**

Yuksel

[45] Date of Patent: **** Dec. 13, 1994**

[54] **MAGNETIC FUEL CONDITIONER**

[75] Inventor: **Levent Yuksel**, Philadelphia, Pa.

[73] Assignee: **North American Power Technologies**, Philadelphia, Pa.

[**] Term: **14 Years**

[21] Appl. No.: **937,655**

[22] Filed: **Aug. 26, 1992**

[52] U.S. Cl. **D23/207**

[58] Field of Search 210/222-223, 210/97, 198.1, 205-206, 231, 244-246, 257.1-257.2, 258, 260-261, 275, 282, 287-290, 295, 321.6, 321.78, 348, 416.3, 443-449; D23/207-210

[56] **References Cited**

U.S. PATENT DOCUMENTS

D. 299,266	1/1989	Kulish	D23/207
D. 327,113	6/1992	Young et al.	D23/207
D. 331,274	11/1992	Kashani	D23/207
D. 337,148	7/1993	Burns	D23/207
D. 342,304	12/1993	Kashani	D23/207
4,995,425	2/1991	Weisenbarger et al.	210/222 X
5,024,756	6/1991	McGrath et al.	210/222

OTHER PUBLICATIONS

- Fuel Economizer™ An NAPT Product Sales Brochure, 1992 (1 Page).
- Gasbooster Sales Brochure From Saveco Technologies Corp., 1992 (2 Pages).
- Magnetizer® Fuel Energizer Sales Brochure From Magnetizer Group Inc., 1990 (2 Pages).

Aqua Magnetics® International, Inc. Sales Brochure, (1 Page, Date unknown).

Pesco Fuel Conditioning Advertisement, (1 Page, Date unknown).

Magnetizer Journal, Magnetizer Group, Inc., 1988 (Cover and 3 Pages Illustrating Product).

Primary Examiner—Wallace R. Burke

Assistant Examiner—M. H. Tung

Attorney, Agent, or Firm—Volpe and Koenig

[57] **CLAIM**

The ornamental design for a magnetic fuel conditioner, as shown and described.

DESCRIPTION

FIG. 1 is a perspective view of a magnetic fuel conditioner according to my design;

FIG. 2 is a top plan view of the embodiment of FIG. 1;

FIG. 3 is a left side elevation view thereof, the right side is a mirror image except for the attachment band;

FIG. 4 is a front elevation of the embodiment of FIG. 1;

FIG. 5 is a rear elevation of the embodiment of FIG. 1;

FIG. 6 is a bottom plan view of the embodiment of FIG. 1;

FIG. 7 is a perspective view of a second embodiment thereof;

FIG. 8 is a top plan view of the embodiment of FIG. 7;

FIG. 9 is a left side elevation of the embodiment of FIG. 7 with the right side elevation being the mirrored image thereof;

FIG. 10 is a front elevation of the embodiment of FIG. 7 with the rear elevation being the mirrored image thereof; and,

FIG. 11 is a bottom plan view of the embodiment of FIG. 7.

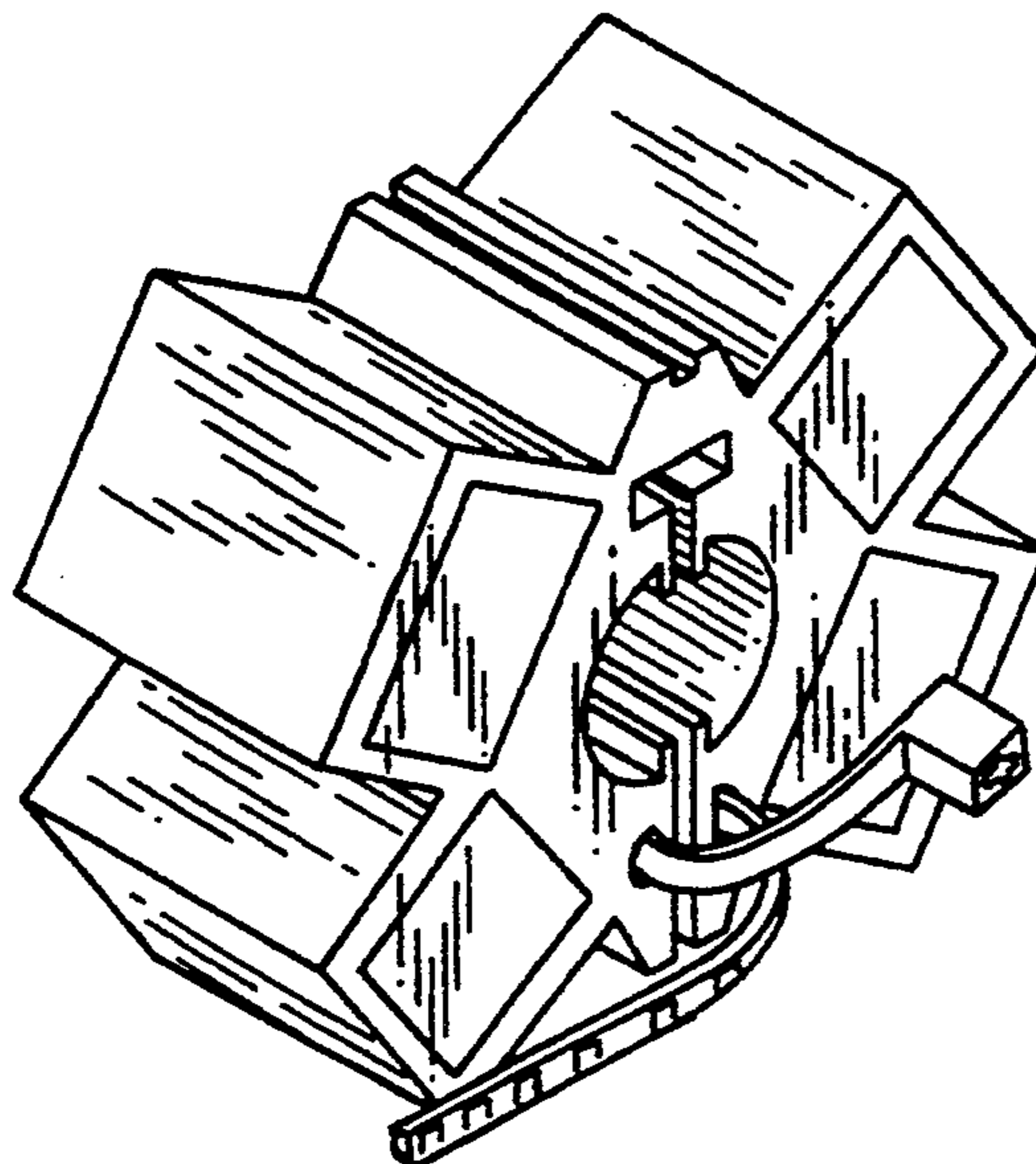

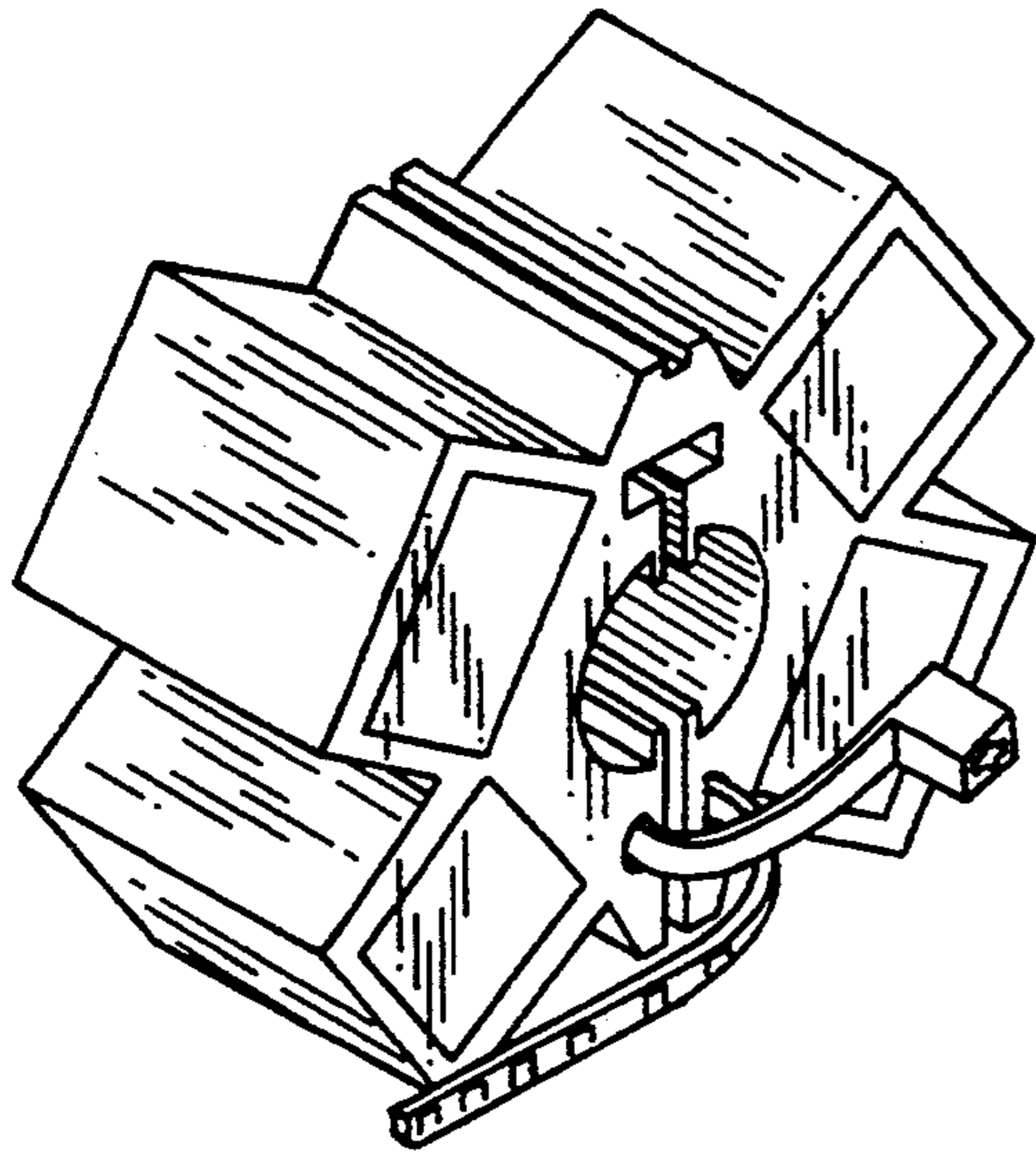

FIG. 1

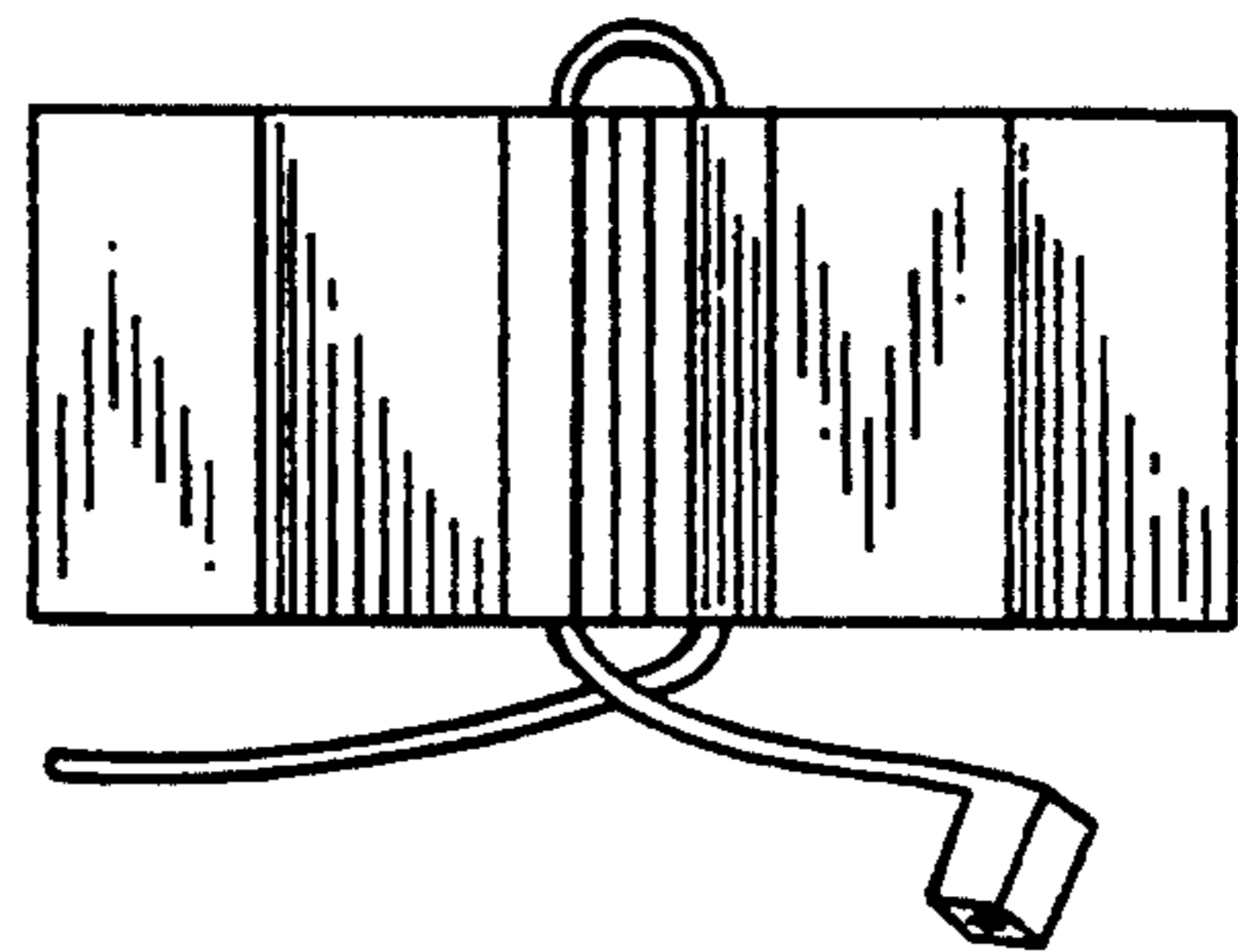

FIG. 2

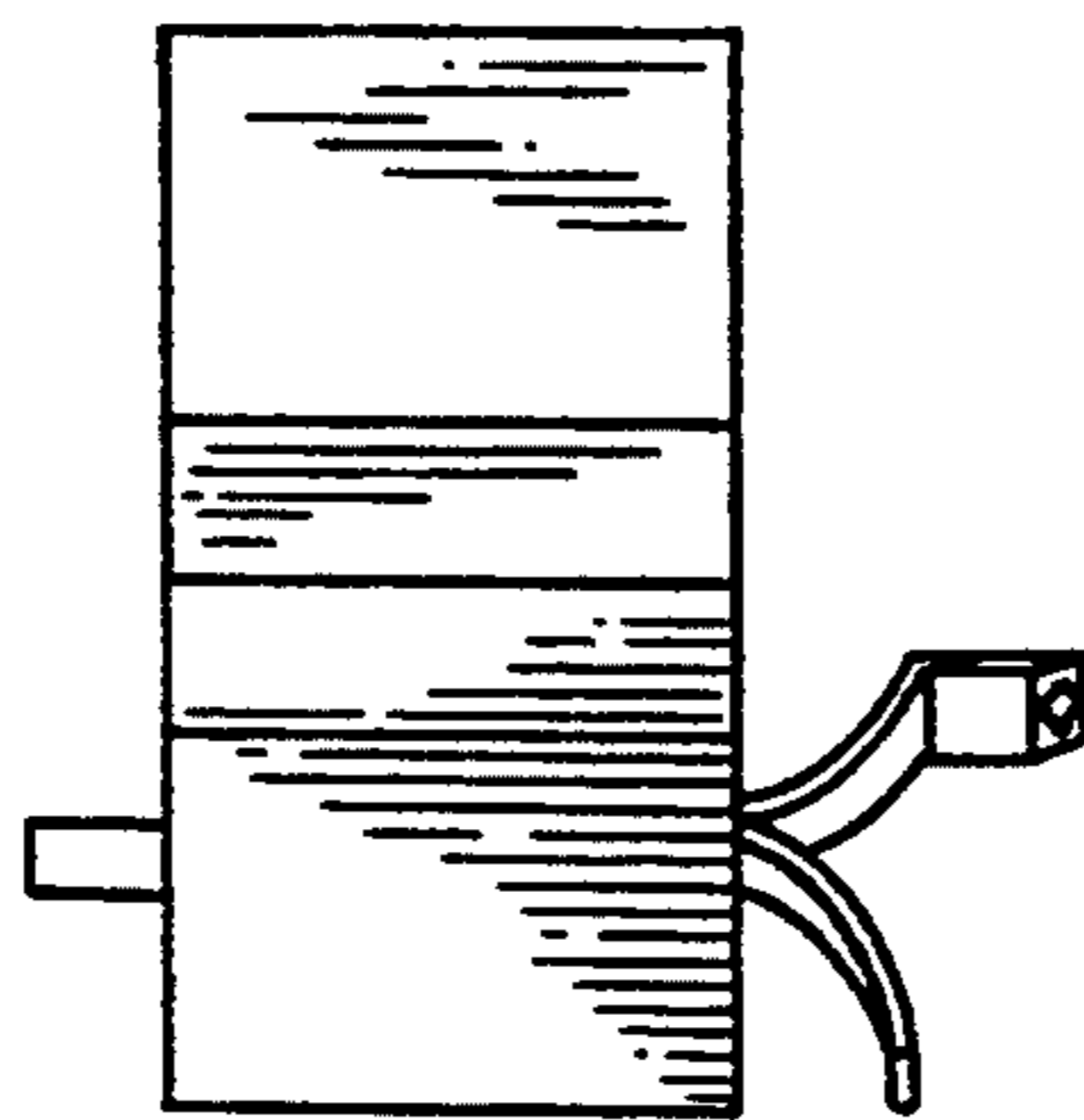

FIG. 3

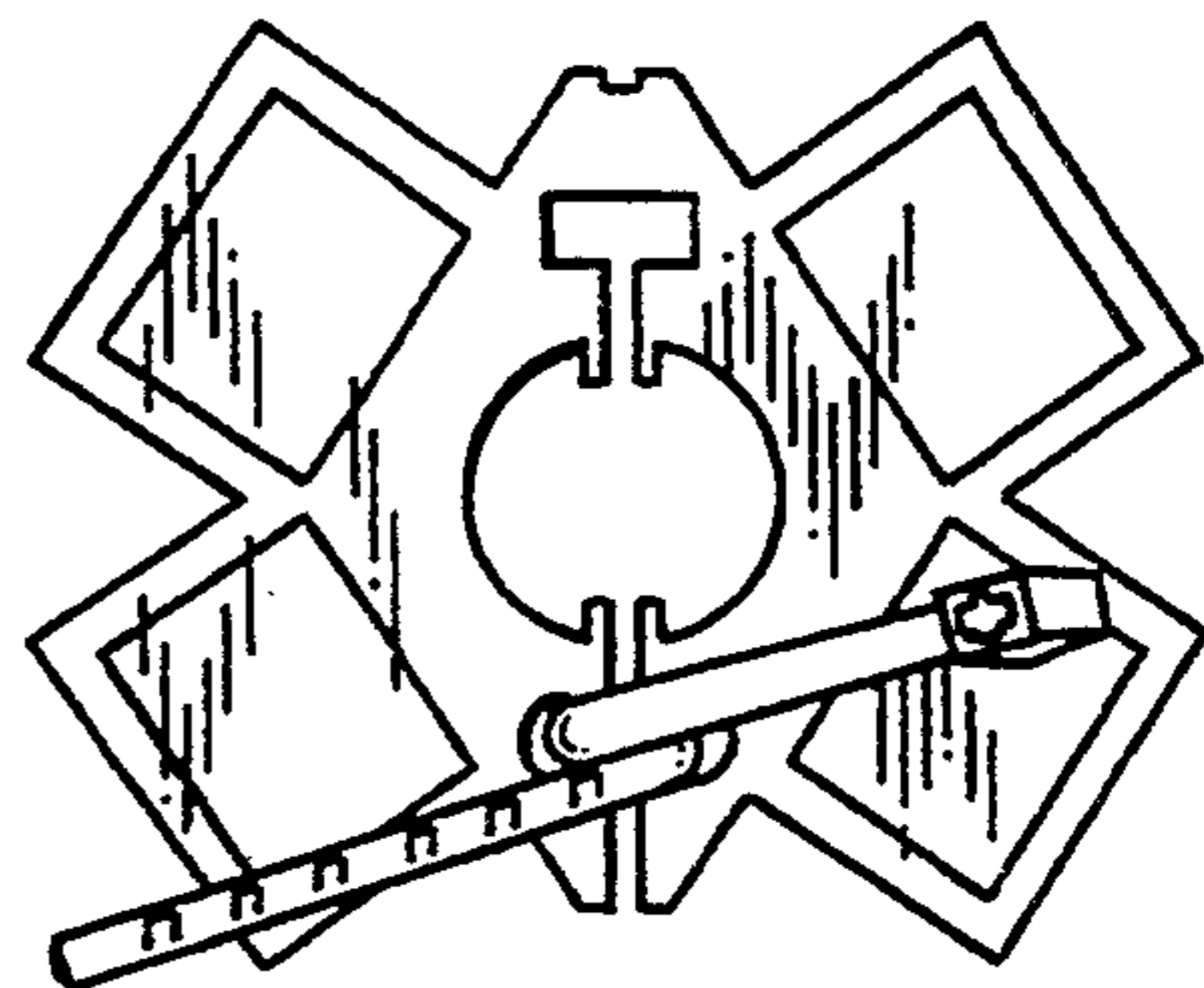

FIG. 4

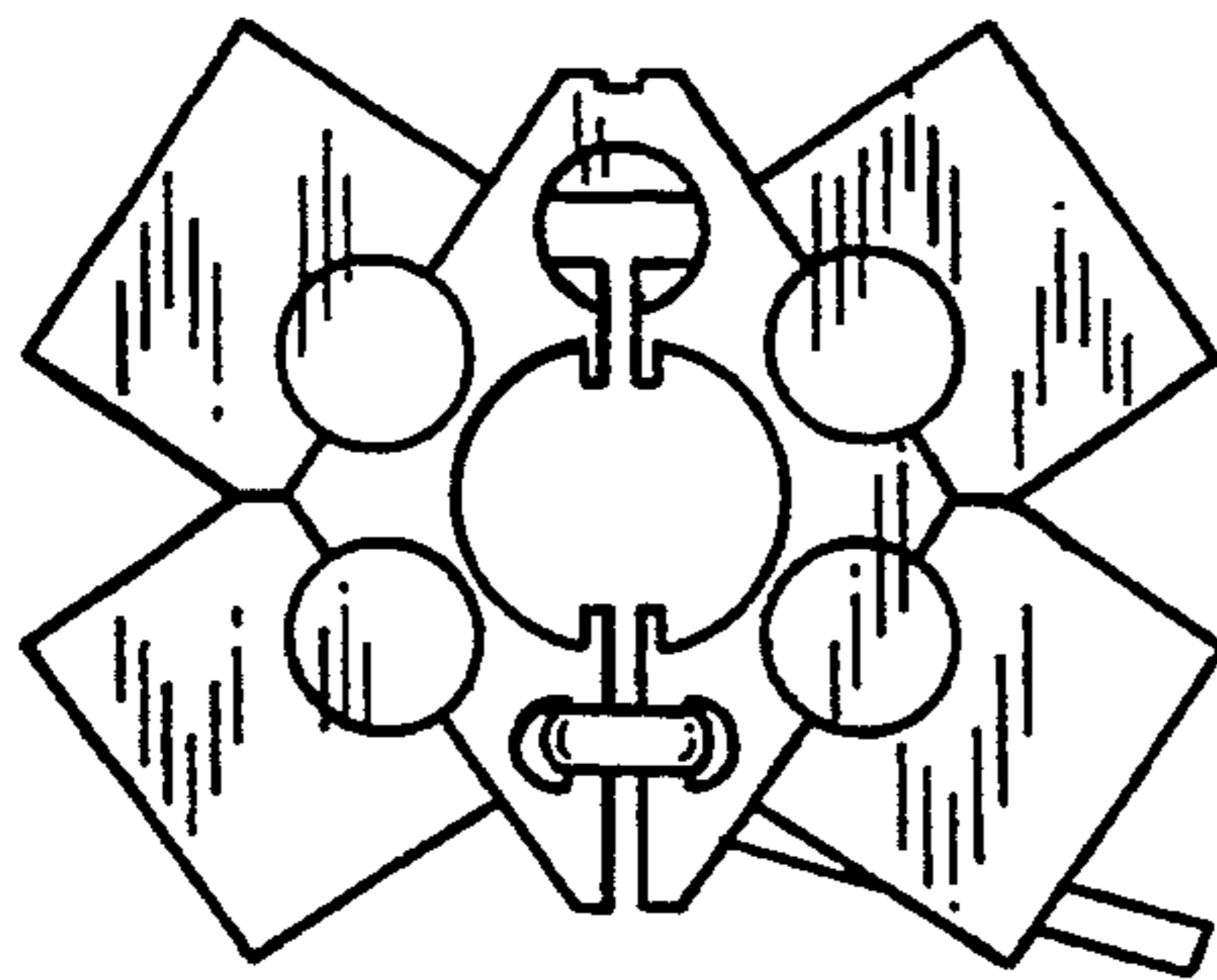

FIG. 5

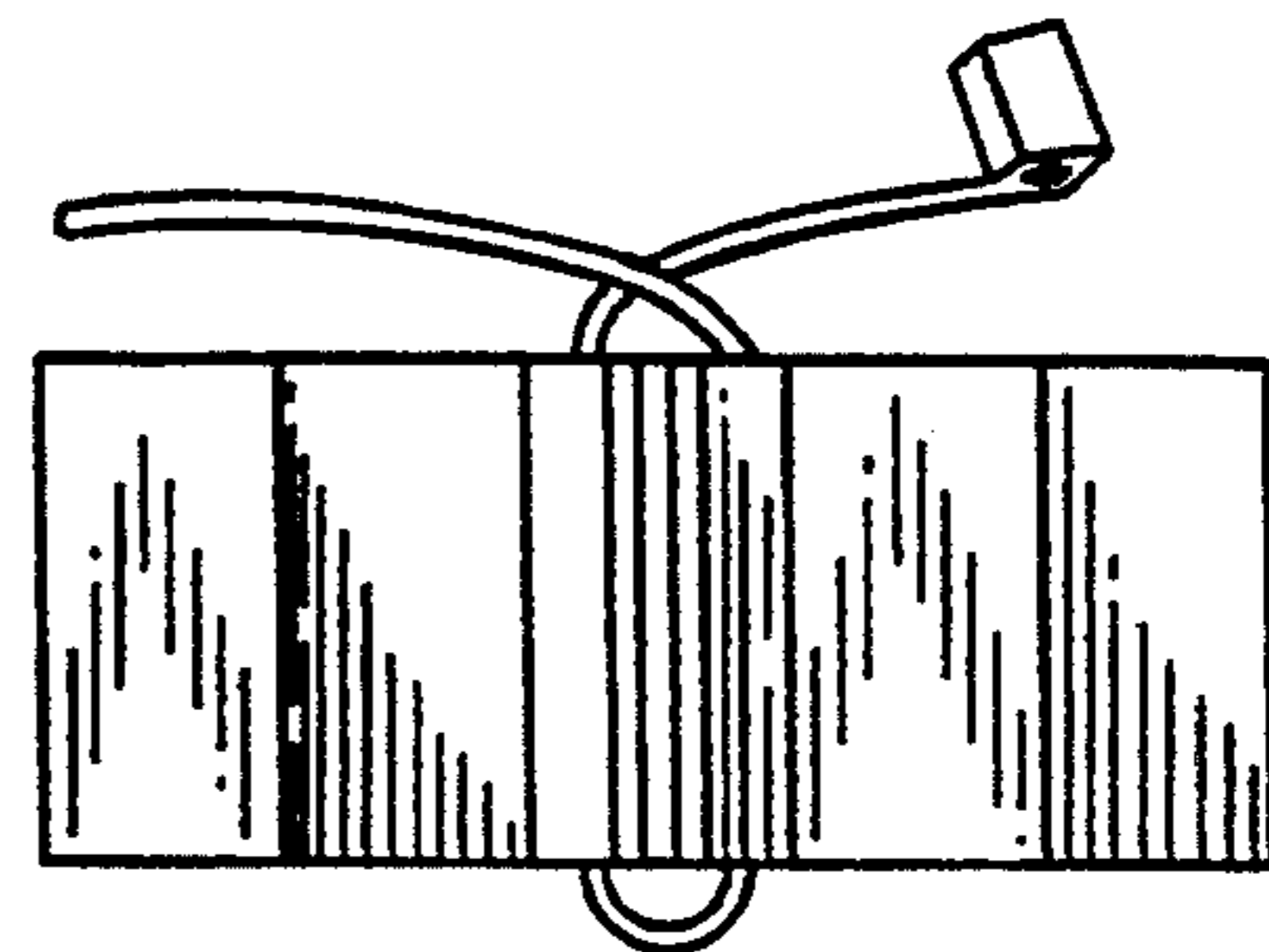

FIG. 6

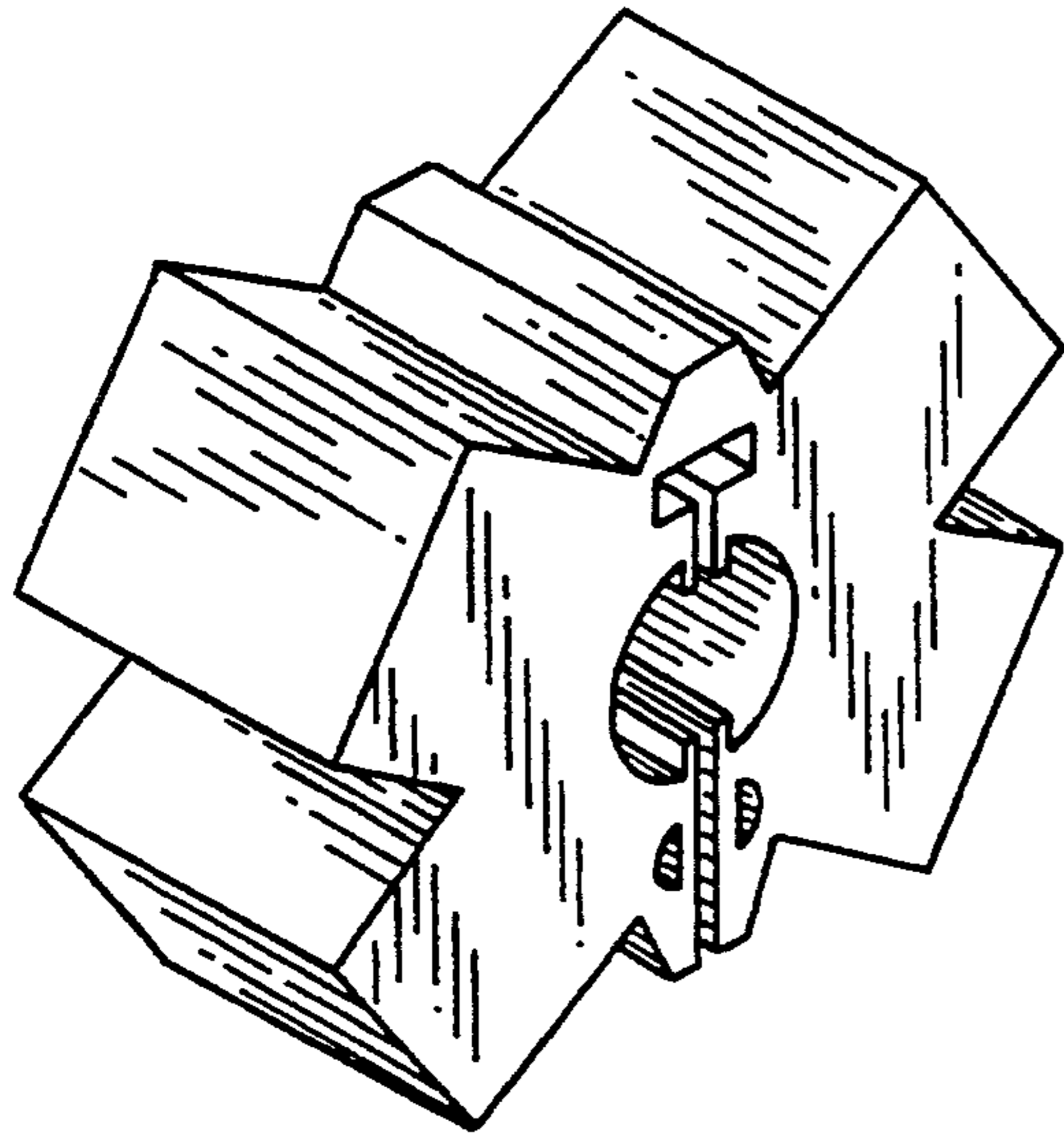

FIG. 7

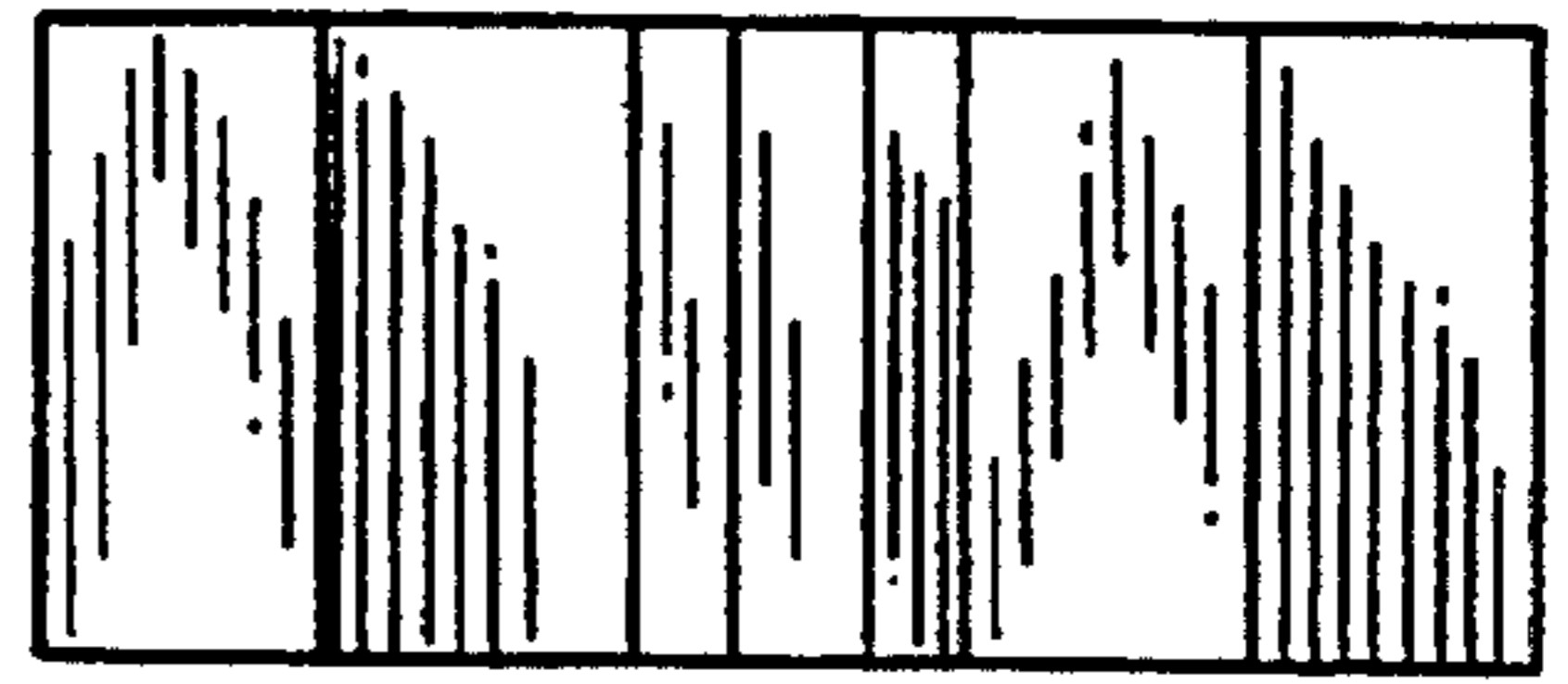

FIG. 8

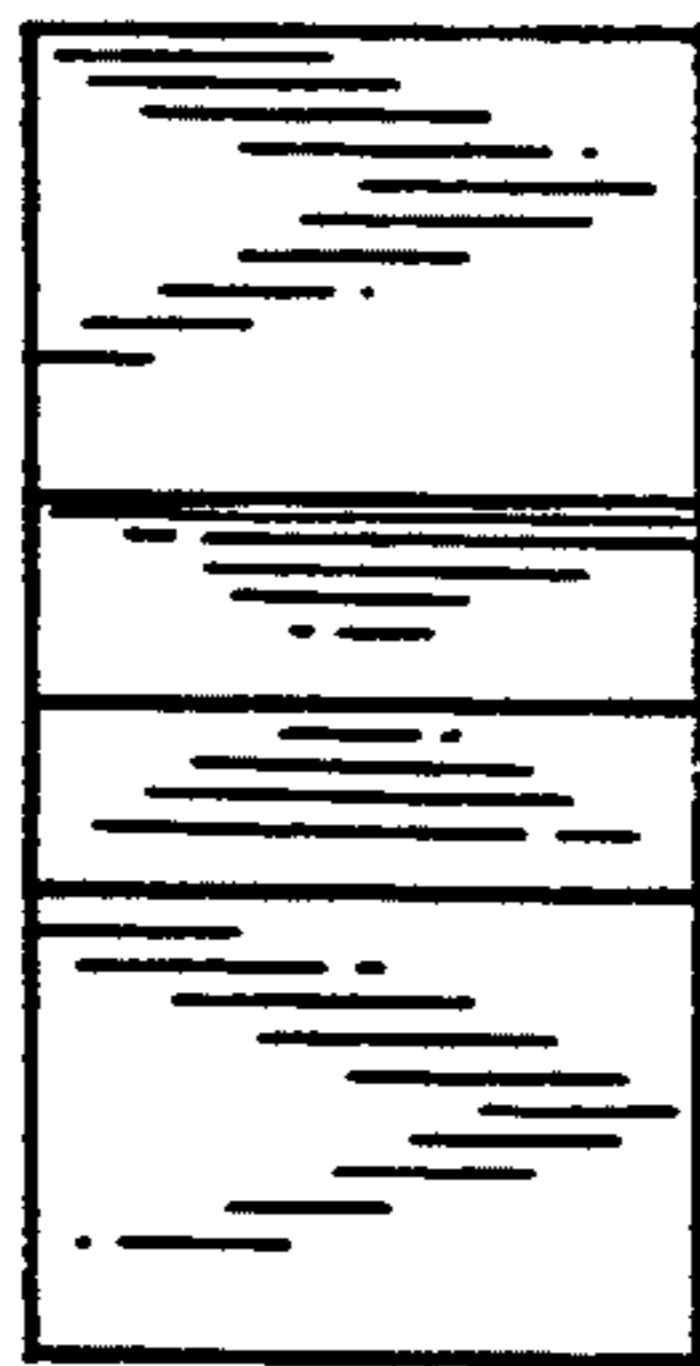

FIG. 9

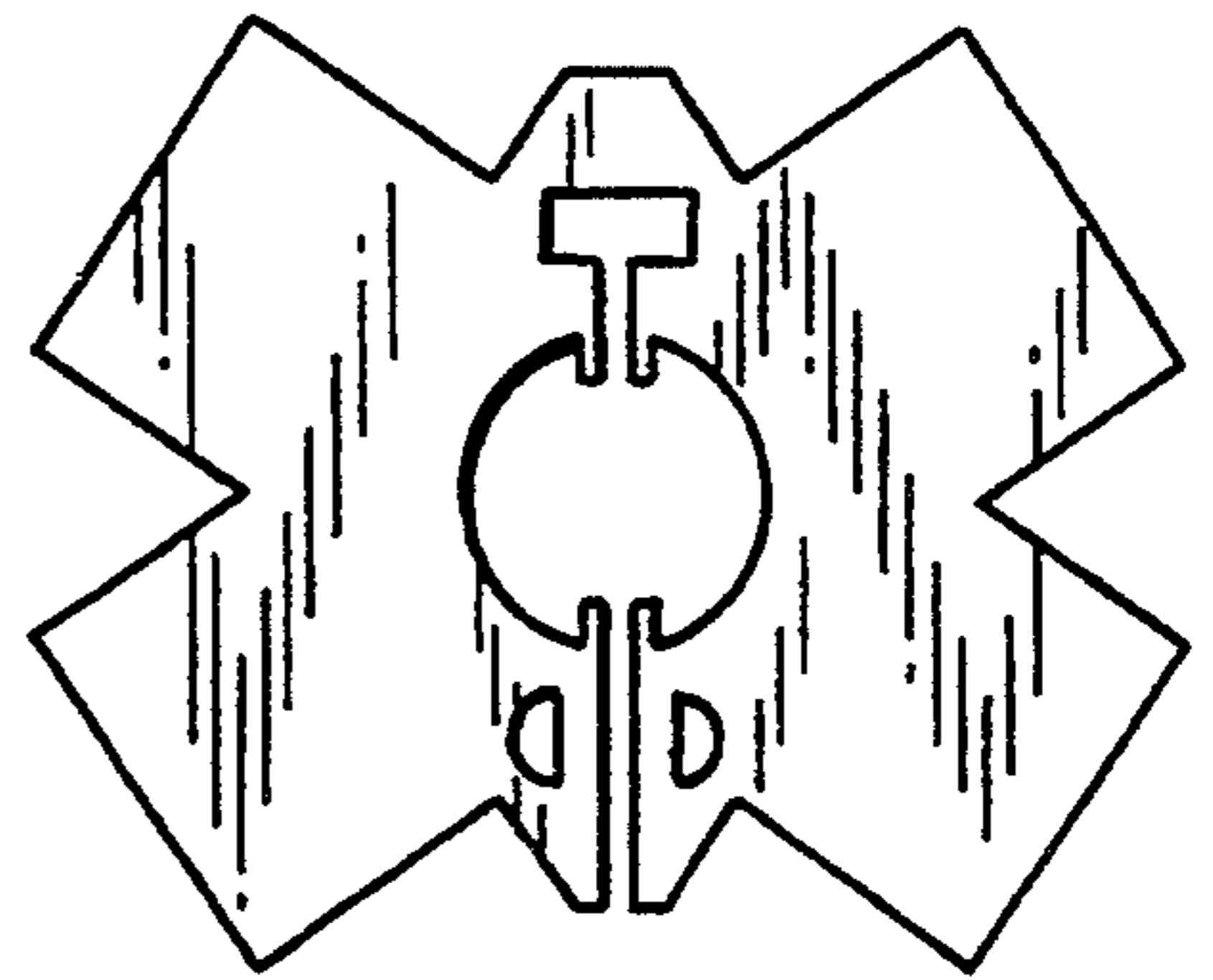

FIG. 10

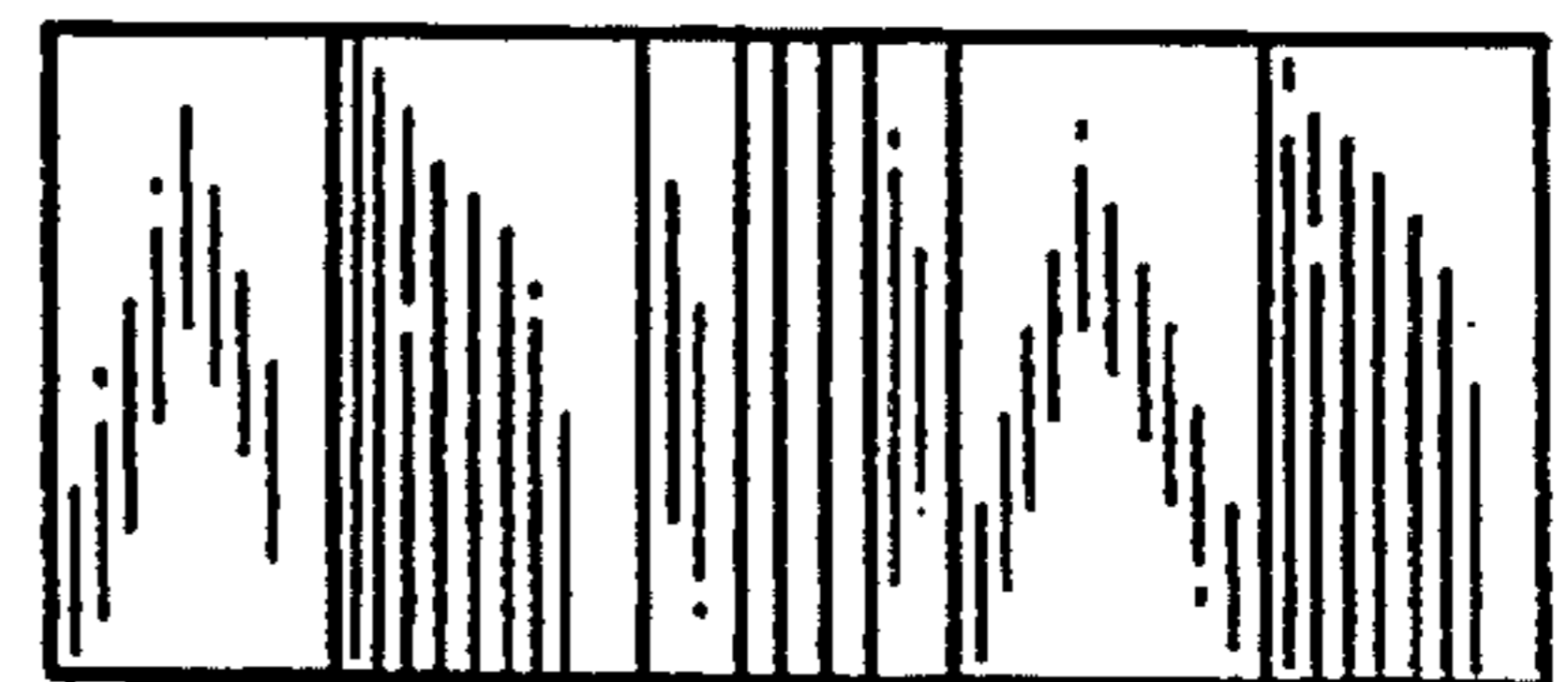

FIG. 11