



US00D353320S

United States Patent [19]

Eizen

[11] Patent Number: Des. 353,320

[45] Date of Patent: ** Dec. 13, 1994

[54] KEY BLANK

4,922,229 5/1990 Guent D8/347 X

[75] Inventor: Noach Eizen, Rishon Lezion, Israel

[73] Assignee: Mul-T-Lock Ltd., Yavne, Israel

[**] Term: 14 Years

[21] Appl. No.: 13,001

[22] Filed: Sep. 14, 1993

Related U.S. Application Data

[62] Division of Ser. No. 643,668, Jan. 18, 1991, Pat. No. Des. 342,887.

[30] Foreign Application Priority Data

Jul. 23, 1990 [IL] Israel 16728

Nov. 13, 1990 [IL] Israel 17108

[52] U.S. Cl. D8/347

[58] Field of Search D8/347-348;
70/336, 344, 393, 395, 402, 405, 408, 456 R

[56] References Cited

U.S. PATENT DOCUMENTS

D. 278,880 5/1985 Widen D8/347

D. 333,973 3/1993 Eizen D8/347

3,349,589 10/1967 Fricke 70/395

3,780,393 12/1973 Gaetke D8/347 X

OTHER PUBLICATIONS

Iico Unican Catalogue No. 60R (1984) p. S6, Lowe & Fletcher LF3 Key.

Iico Unican Catalogue No. 60R (1984) p. 116, Chrysler Sec Key.

Iico Unican Catalogue No. 60R (1984) p. 84, Key PJE. Photocopy of key blank 73VB for Volkswagon made between 1975 and 1984.

Primary Examiner—Brian N. Vinson

Attorney, Agent, or Firm—Ladas & Parry

[57] CLAIM

The ornamental design for a key blank, as shown.

DESCRIPTION

FIG. 1 is a front elevational view of a key blank showing my new design;

FIG. 2 is an enlarged horizontal cross-sectional view thereof, taken midway along the length of the key blade;

FIG. 3 is a right side elevational view thereof;

FIG. 4 is a top plan view thereof;

FIG. 5 is a rear elevational view thereof;

FIG. 6 is a left side elevational view thereof; and,

FIG. 7 is a bottom plan view thereof.

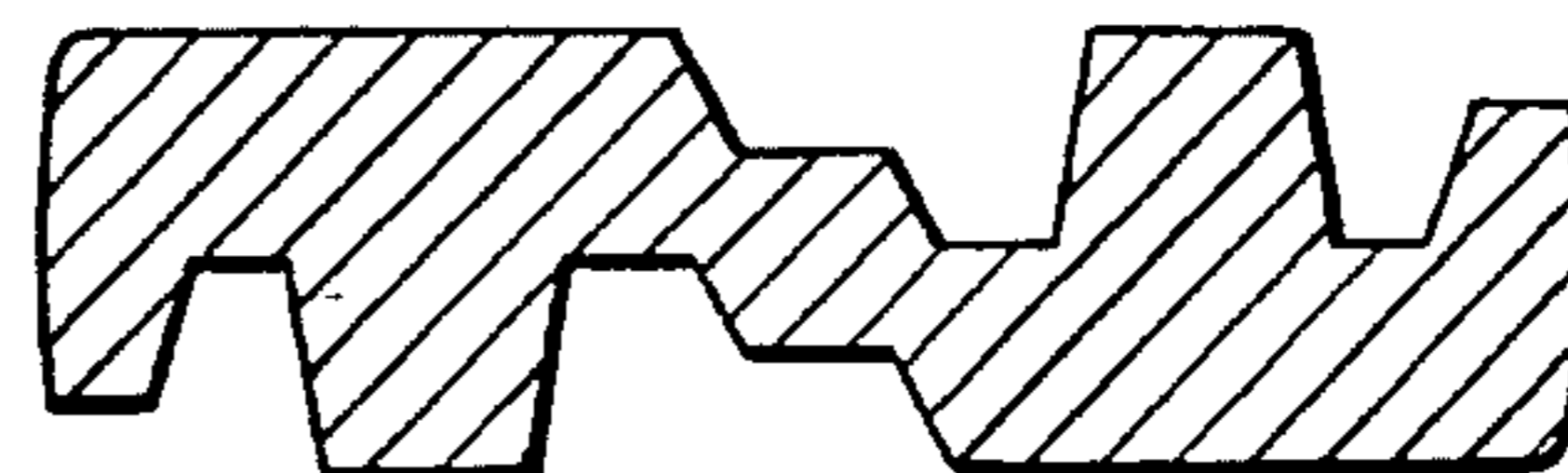
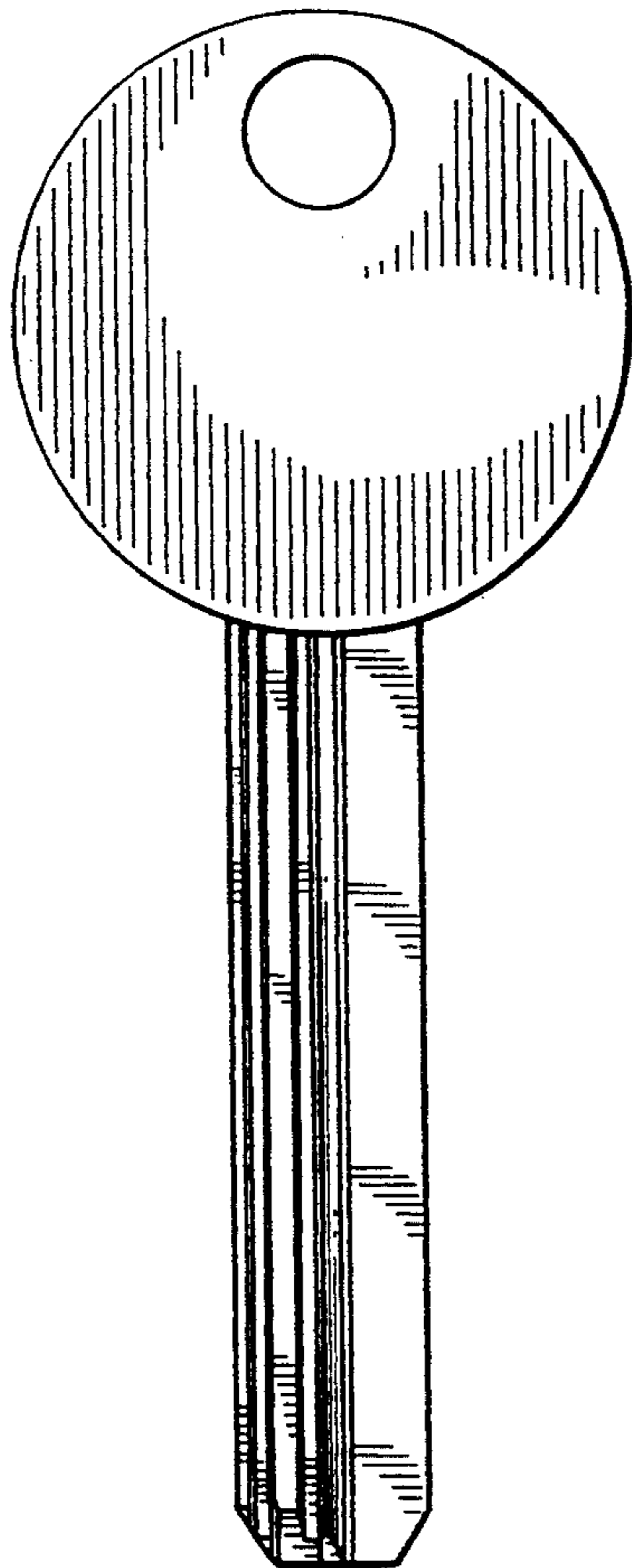

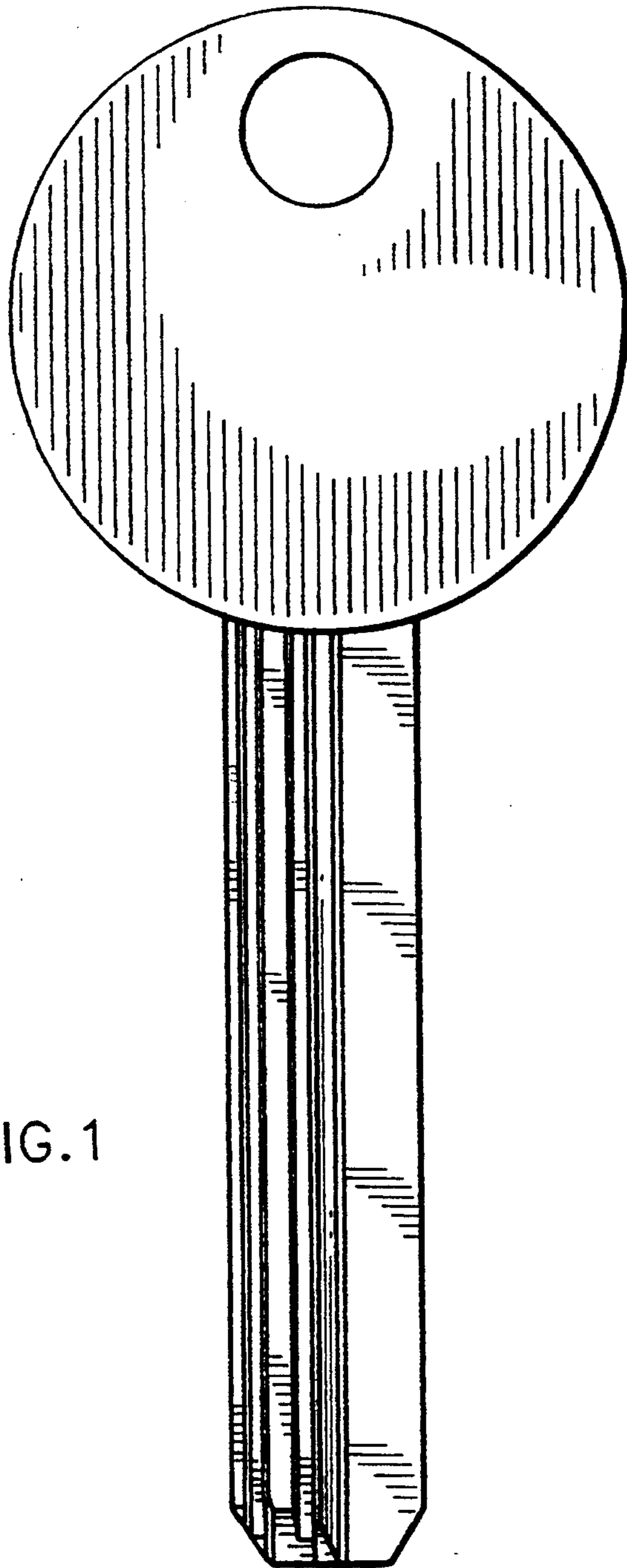

FIG. 1



FIG. 3

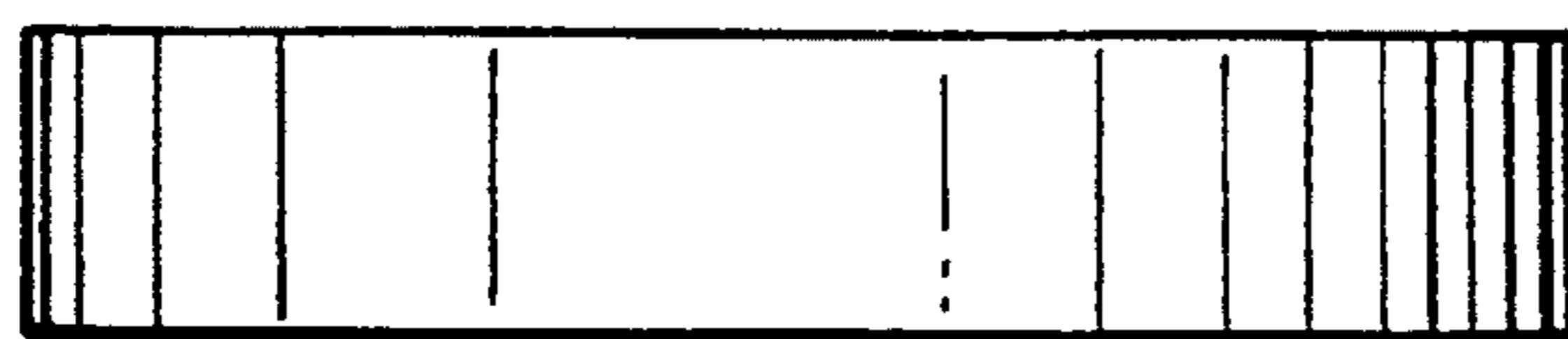

FIG. 4

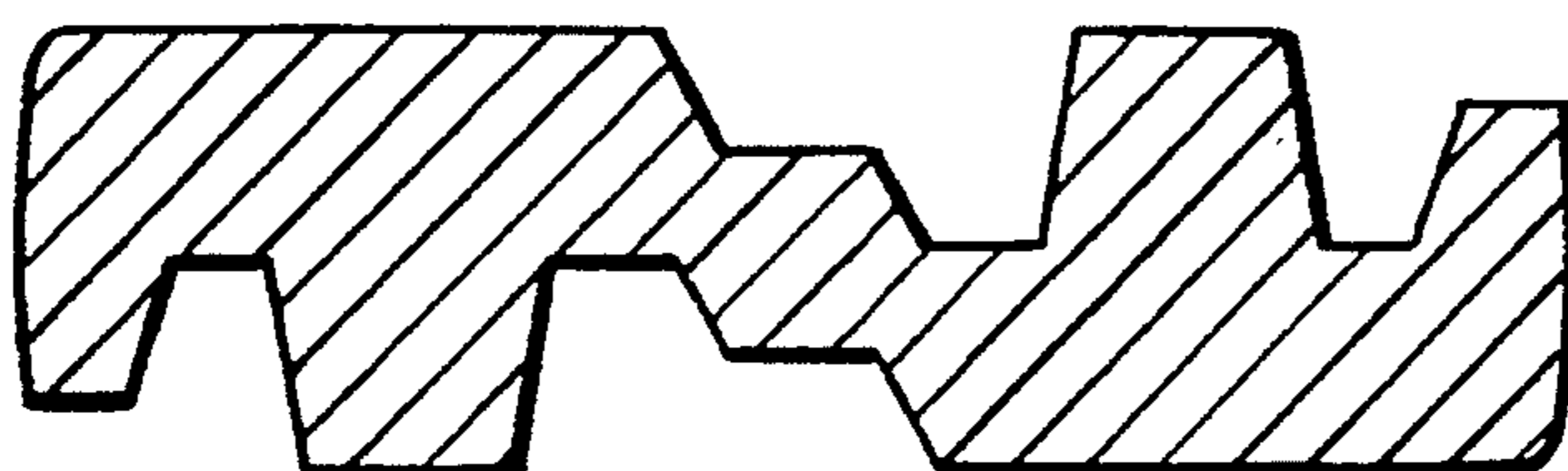

FIG. 2

FIG. 7

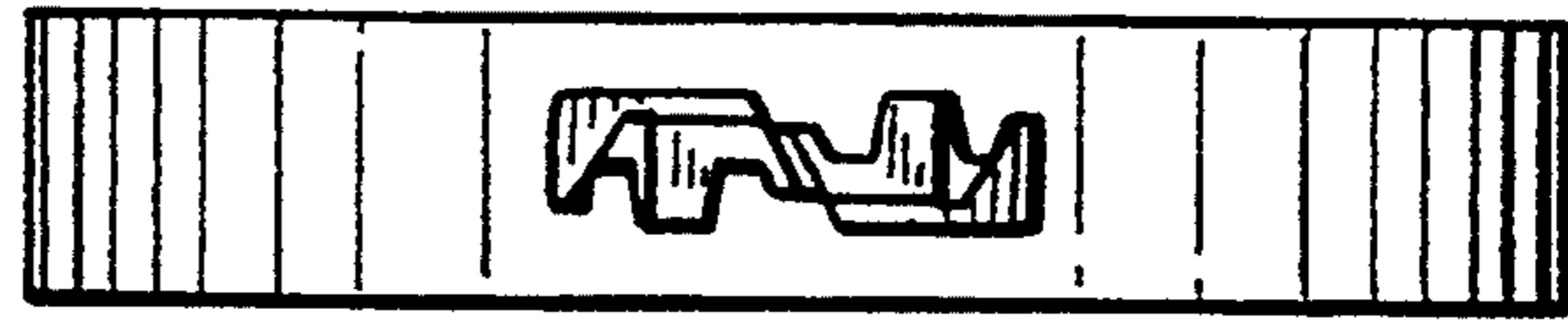

FIG. 6

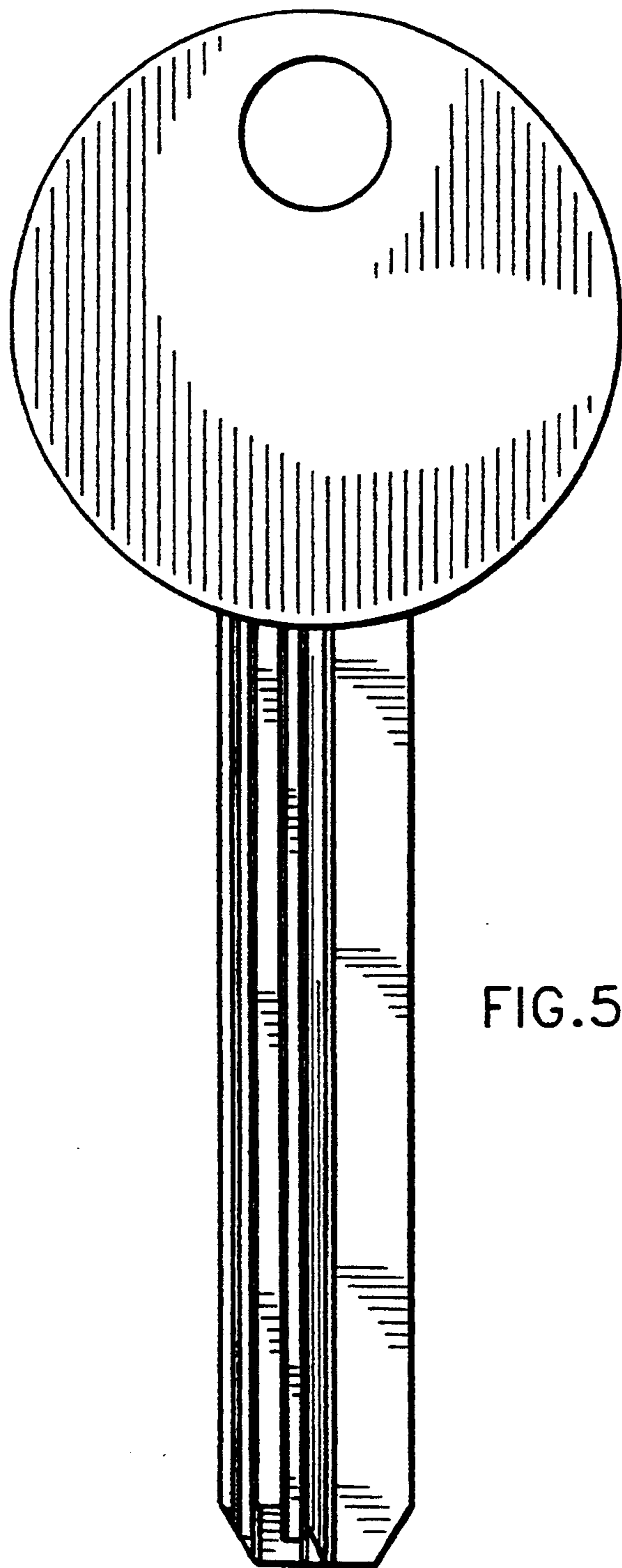

FIG. 5