



US00D353169S

United States Patent [19]

[11] Patent Number: **Des. 353,169**

Shirai et al.

[45] Date of Patent: **** Dec. 6, 1994**

[54] **SHOOTING SCOPE USED IN SHOOTING GAME SYSTEM**

[75] Inventors: **Ichiro Shirai; Kenichi Sugino**, both of Kyoto, Japan

[73] Assignee: **Nintendo Company Limited**, Kyoto, Japan

[**] Term: **14 Years**

[21] Appl. No.: **9,526**

[22] Filed: **Jun. 16, 1993**

Related U.S. Application Data

[62] Division of Ser. No. 817,409, Jan. 6, 1992, Pat. No. Des. 344,108.

Foreign Application Priority Data

Nov. 22, 1991 [JP] Japan 3-35279
[52] U.S. Cl. **D21/146; D21/13**
[58] Field of Search 446/180, 219, 267, 430, 446/473, 475; 124/25, 56, 71, 81, 83; 273/310-311, 313, 316, 349; 42/54; 222/78-79; D21/145-147, 236-237, 13; D22/101, 103-104, 107-108

[56] References Cited

U.S. PATENT DOCUMENTS

D. 191,872	12/1961	Carter	D21/146
D. 204,469	4/1966	Ryan	D21/146
D. 207,172	3/1967	Ryan	D21/146
D. 253,001	9/1979	Huang	D21/13
D. 316,878	5/1991	Ishiwata	D21/13
D. 338,690	8/1993	Smith, III	D21/13
2,970,519	2/1961	Musser	D21/146
3,919,799	11/1975	Austin, Jr.	D21/146

OTHER PUBLICATIONS

Catalog of "PRO BEAM" for use with Nintendo Entertainment System, by Nintendo, published Nov. 1989.

Primary Examiner—Bernard Ansher

Assistant Examiner—R. Barkai

Attorney, Agent, or Firm—Nixon & Vanderhye

[57] CLAIM

The ornamental design for a shooting scope used in shooting game system, as shown and described.

DESCRIPTION

FIG. 1 is a right front perspective view of my new design;
FIG. 2 is a right rear perspective view thereof;
FIG. 3 is a front elevational view thereof;
FIG. 4 is a rear elevational view thereof;
FIG. 5 is a top plan view thereof;
FIG. 6 is a bottom plan view thereof;
FIG. 7 is a right side view thereof; and,
FIG. 8 is a left side view thereof.

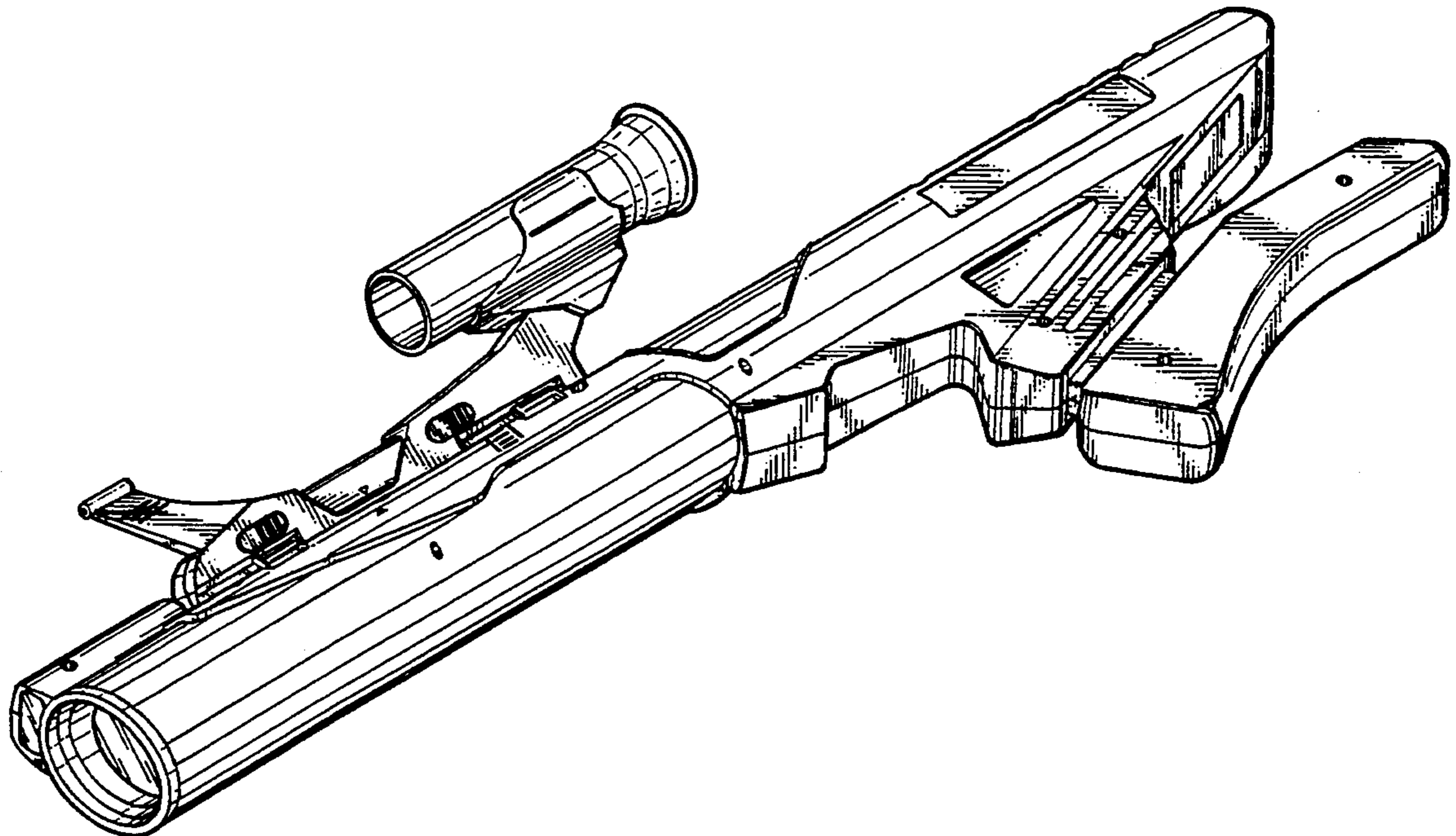

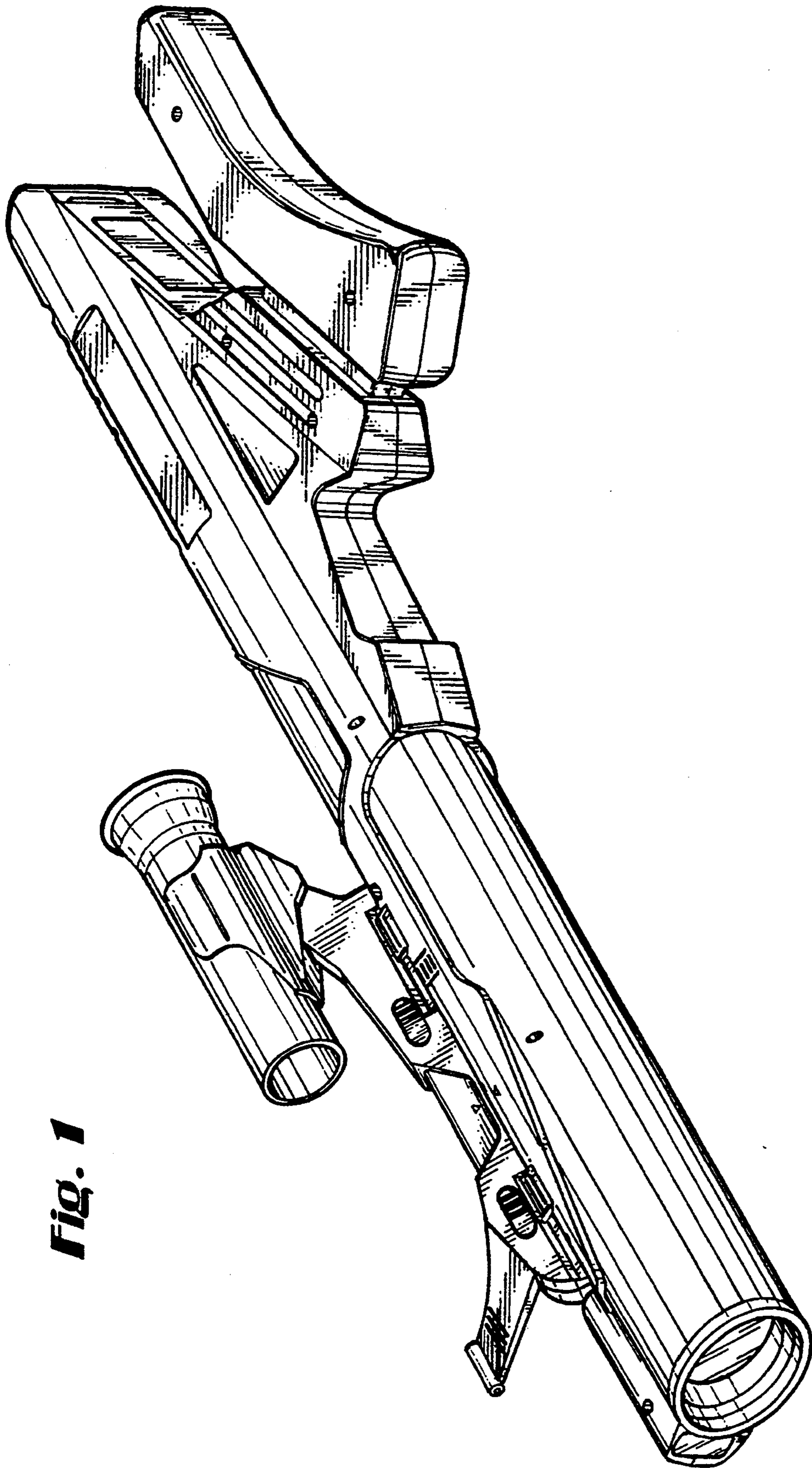

Fig. 1

Fig. 2

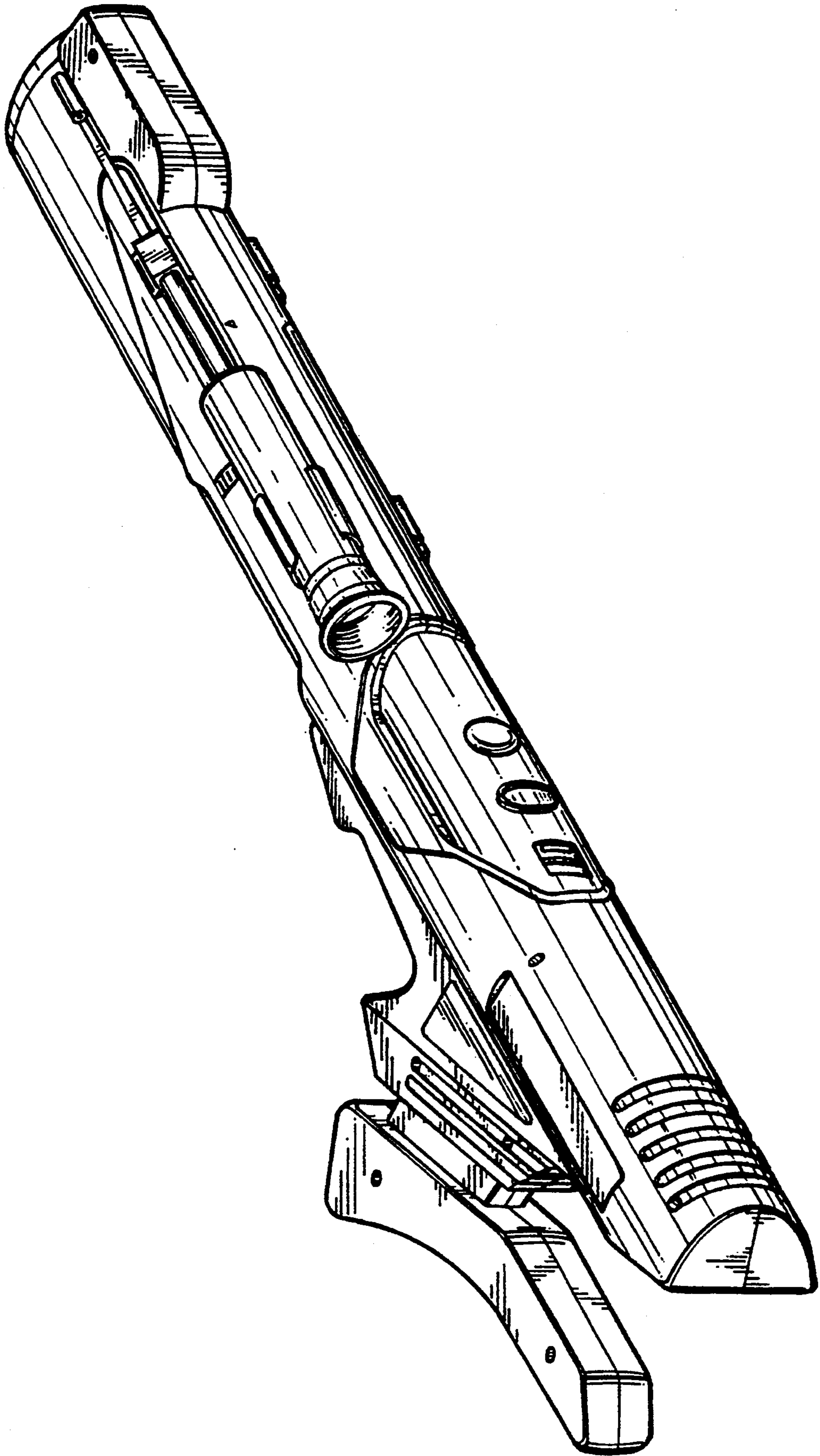

Fig. 3

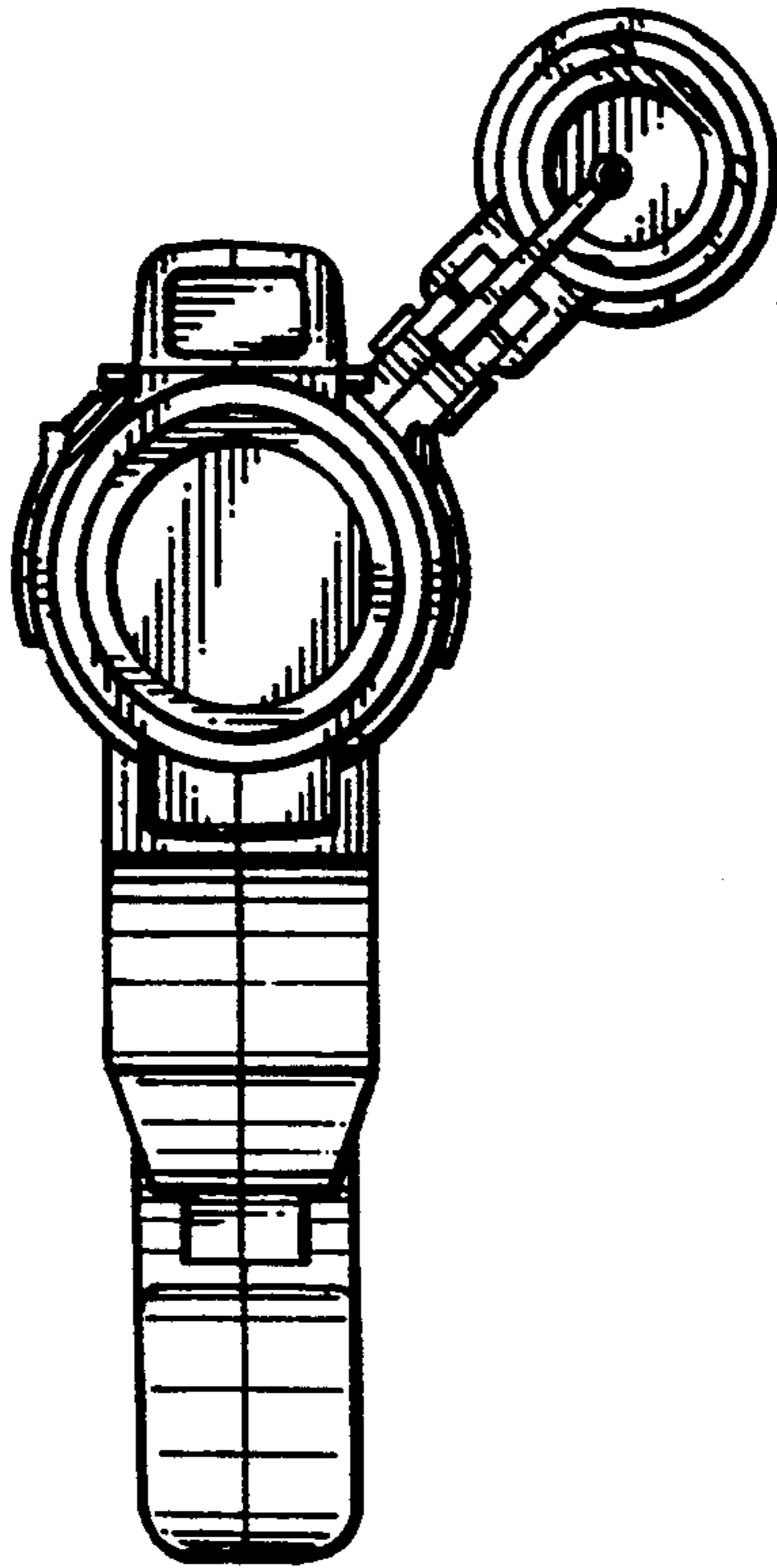

Fig. 4

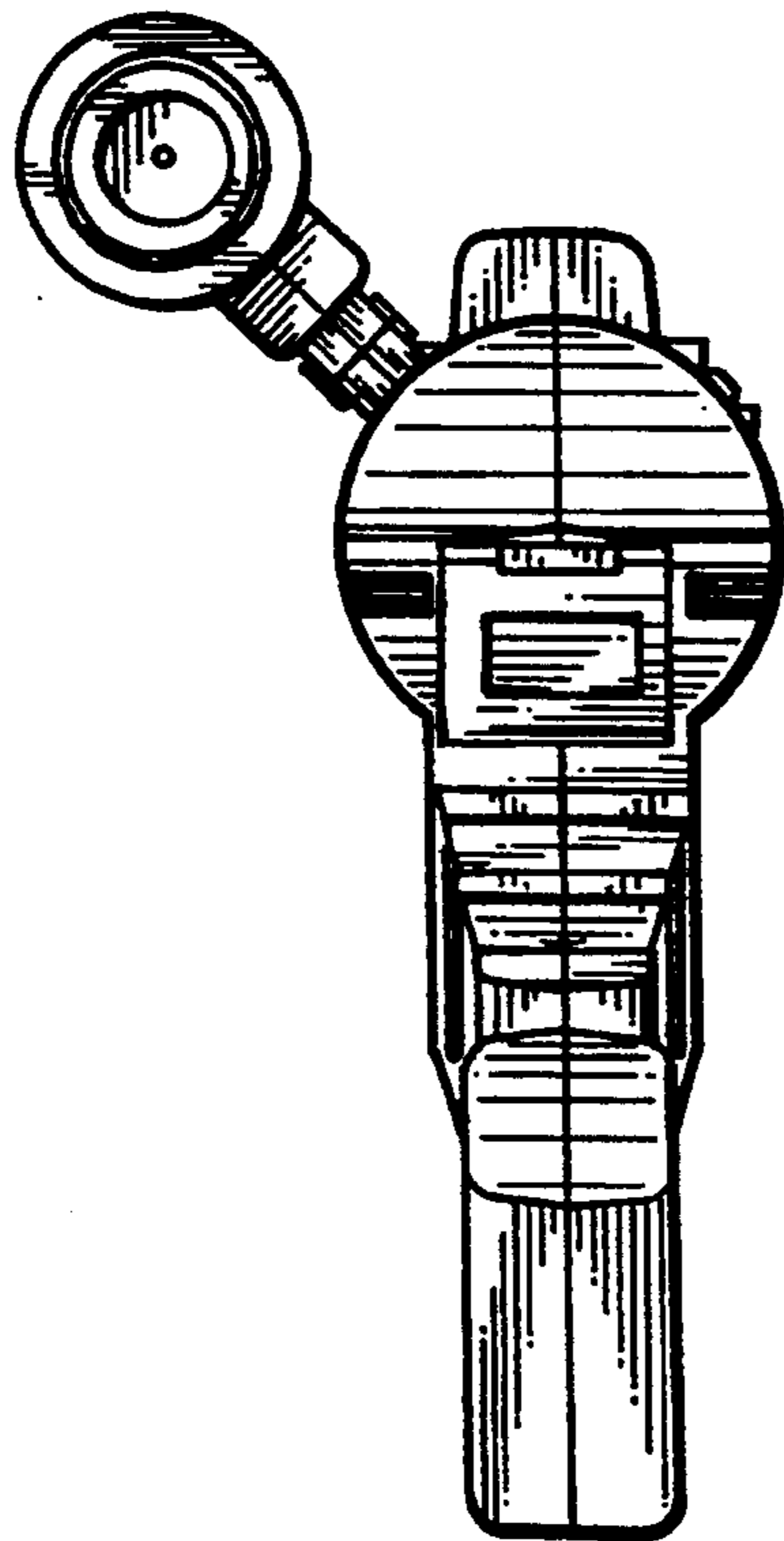

Fig. 5

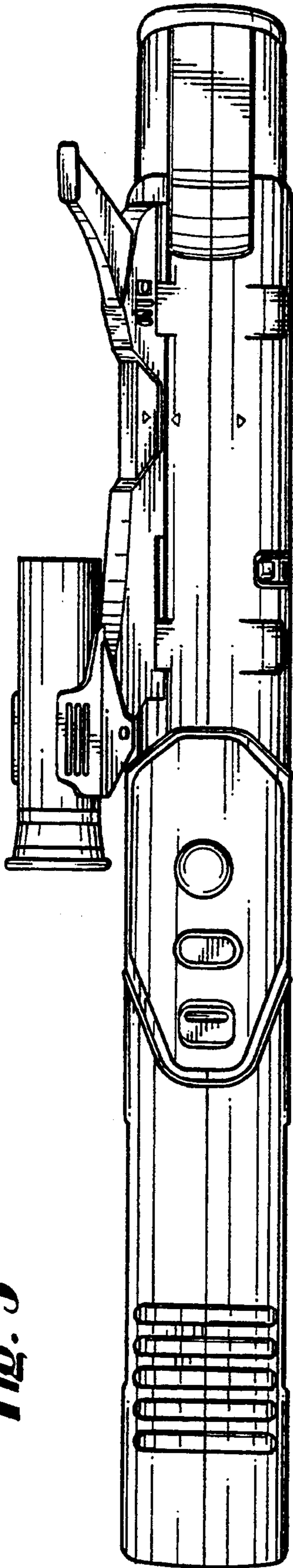
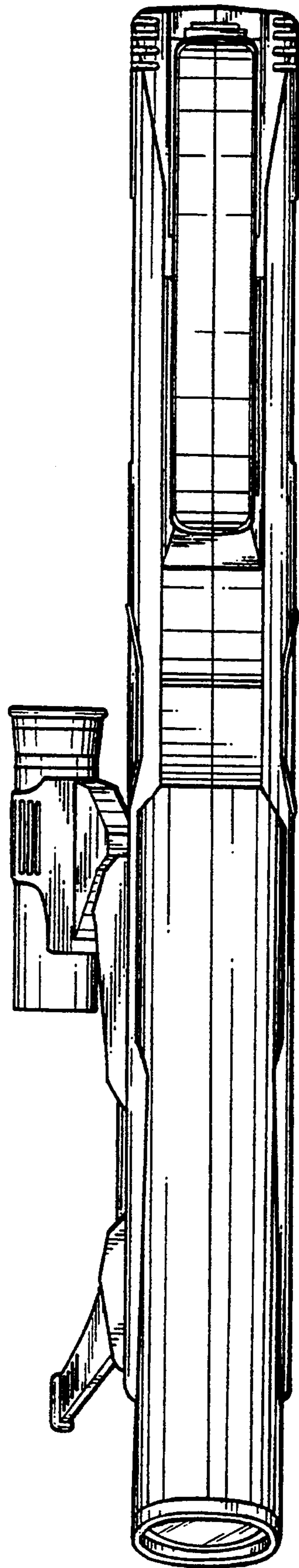

Fig. 6



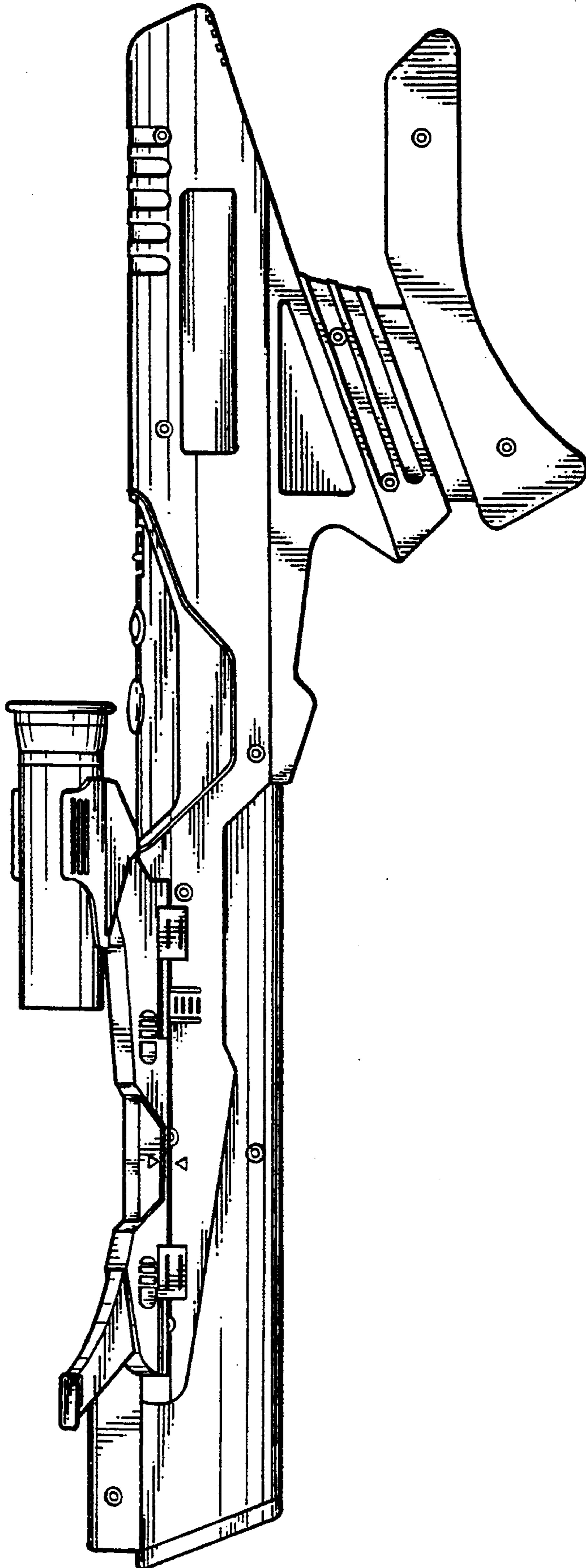

Fig. 7

Fig. 8

