



US00D353163S

United States Patent [19]

[11] Patent Number: Des. 353,163

Henderson

[45] Date of Patent: ** Dec. 6, 1994

[54] REFILLABLE BINGO DABBER

[76] Inventor: Ella Henderson, 5802 Briarwick, Houston, Tex. 77016

[**] Term: 14 Years

[21] Appl. No.: 684,363

[22] Filed: Apr. 12, 1991

[52] U.S. Cl. D21/51; D19/43; D18/15

[58] Field of Search D9/338; 273/148 R; 401/130; D21/48, 51; D18/14-16

[56] References Cited

U.S. PATENT DOCUMENTS

D. 217,308	4/1970	O'Donnell	D18/15
D. 310,249	8/1990	LaLonde	D21/51
D. 316,880	5/1991	Conlan	D21/51
D. 321,596	11/1991	Zierhut	D9/338
D. 325,751	4/1992	Futino	D21/51

Primary Examiner—Bernard Ansher
Assistant Examiner—Sandra Morris
Attorney, Agent, or Firm—Kenneth D. Baugh

[57] CLAIM

The ornamental design for a refillable bingo dabber, as shown and described.

DESCRIPTION

FIG. 1 is a perspective view of a refillable bingo dabber showing my new design;
FIG. 2 is a fragmentary view of a dabber applicator of the refillable bingo dabber with the cap removed;
FIG. 3 is a fragmentary perspective end view of the refillable end of the refillable bingo dabber with the cap removed;
FIG. 4 is an enlarged side view thereof, with the cap removed, the other side being identical;
FIG. 5 is an enlarged fragmentary front view of a dabber applicator, with the cap removed; and,
FIG. 6 is an enlarged fragmentary rear view thereof.

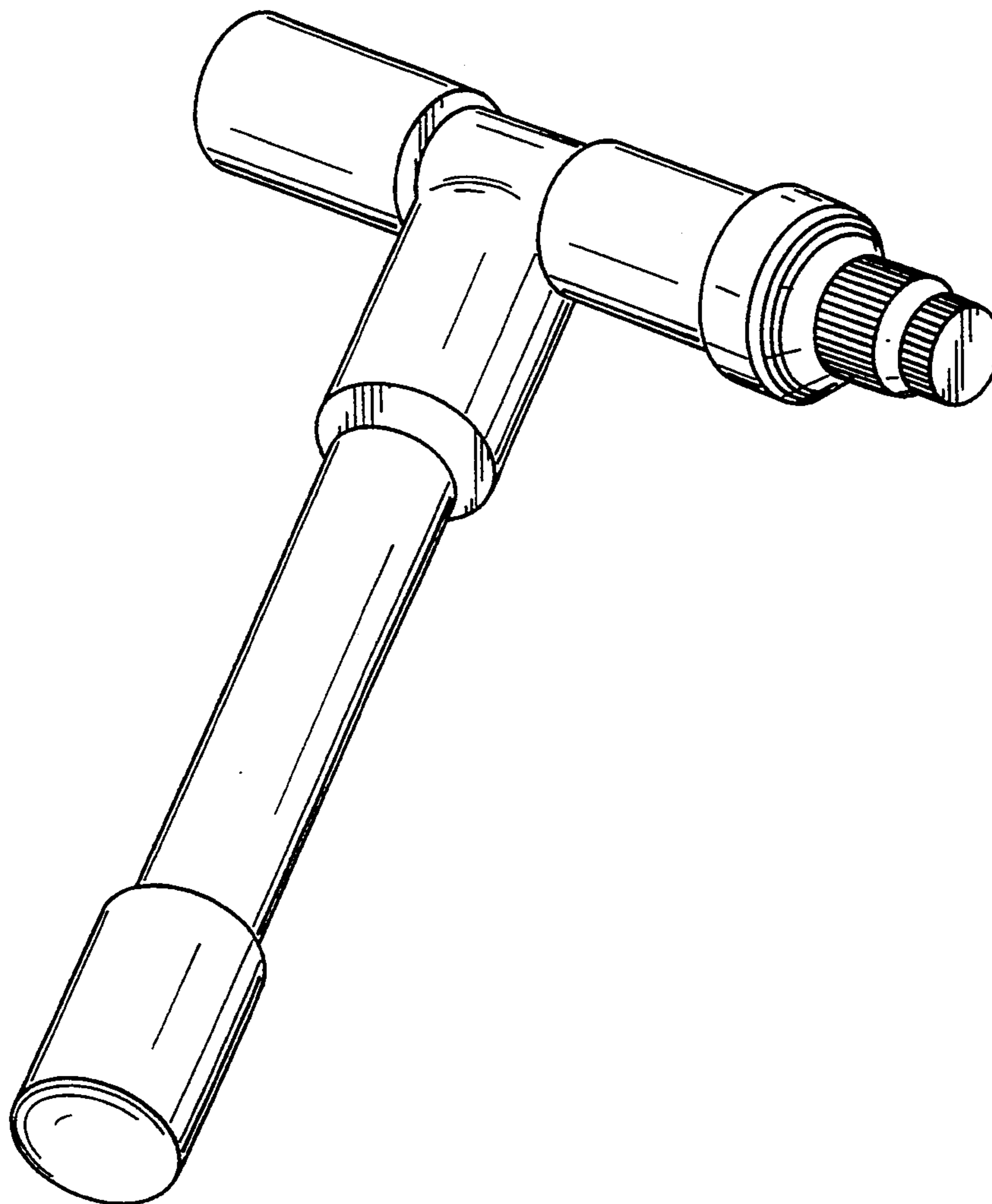

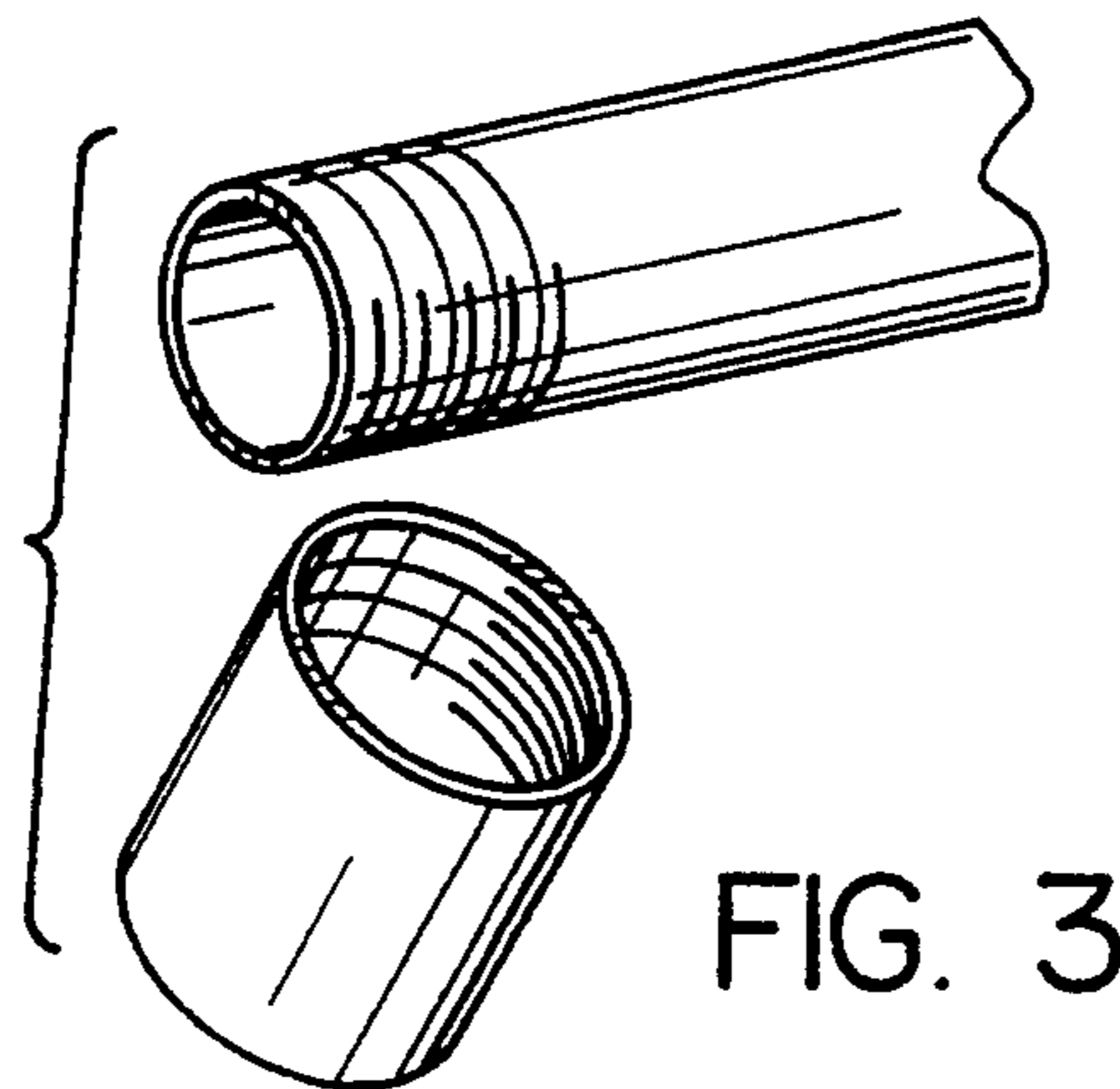
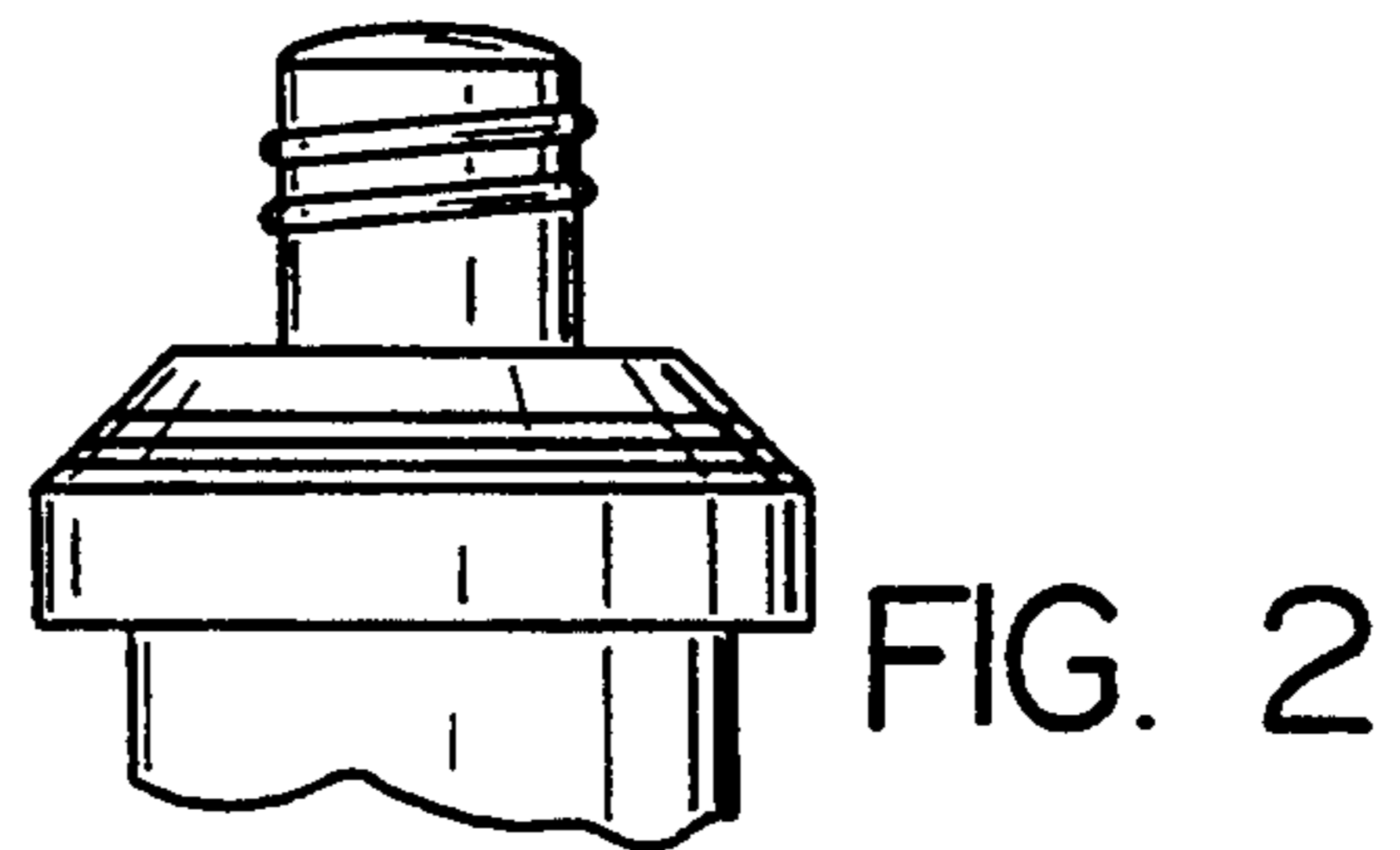
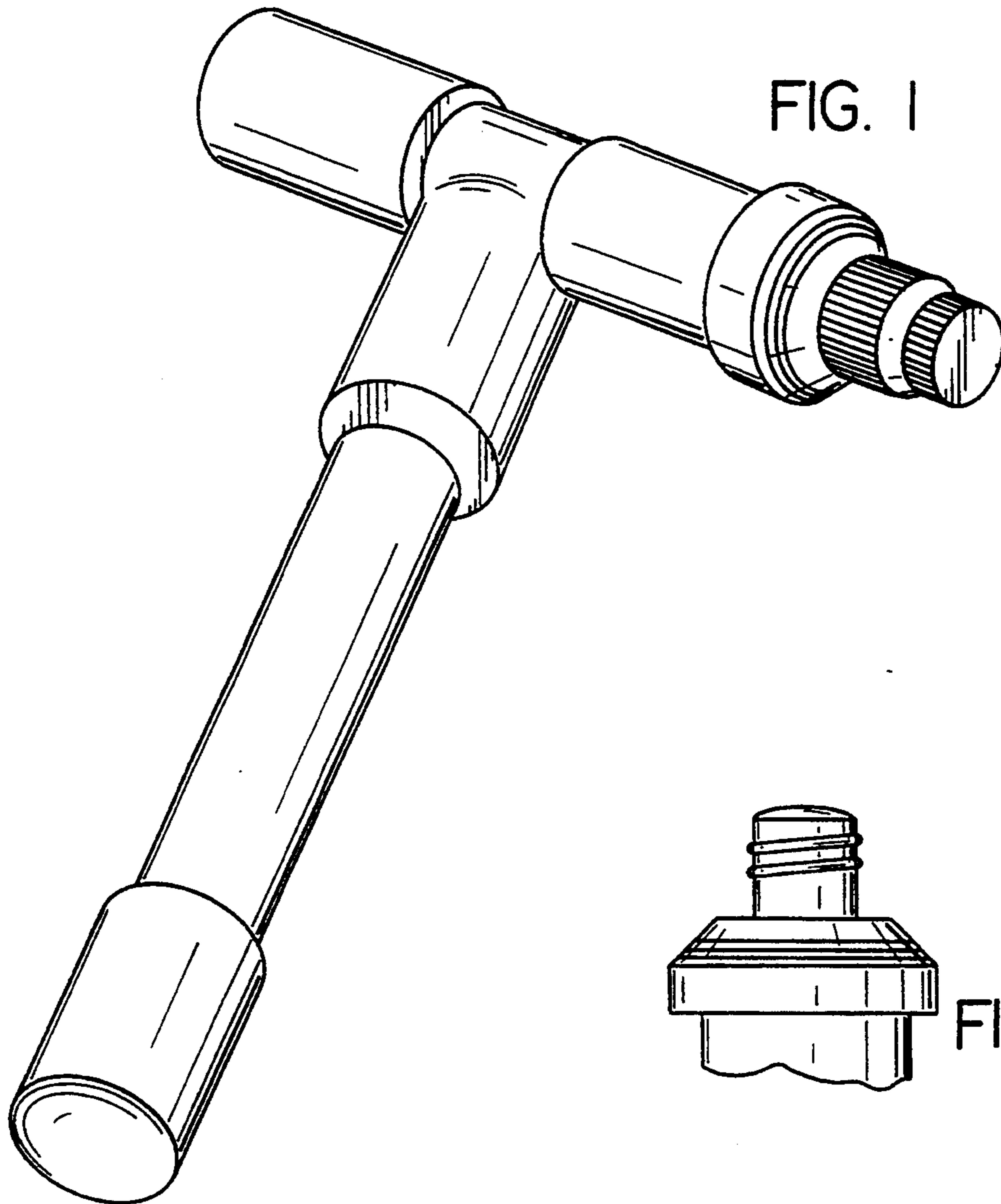

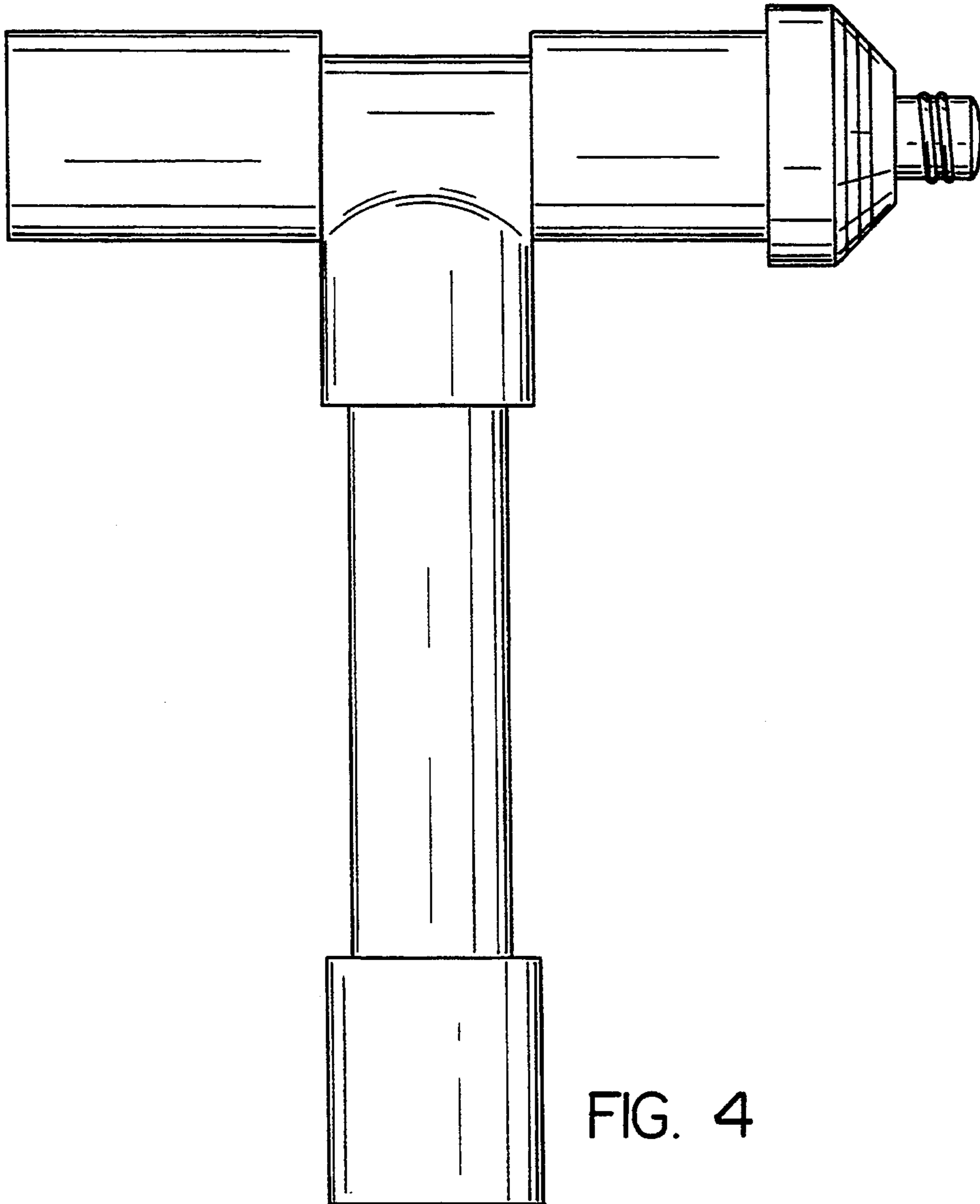

FIG. 4

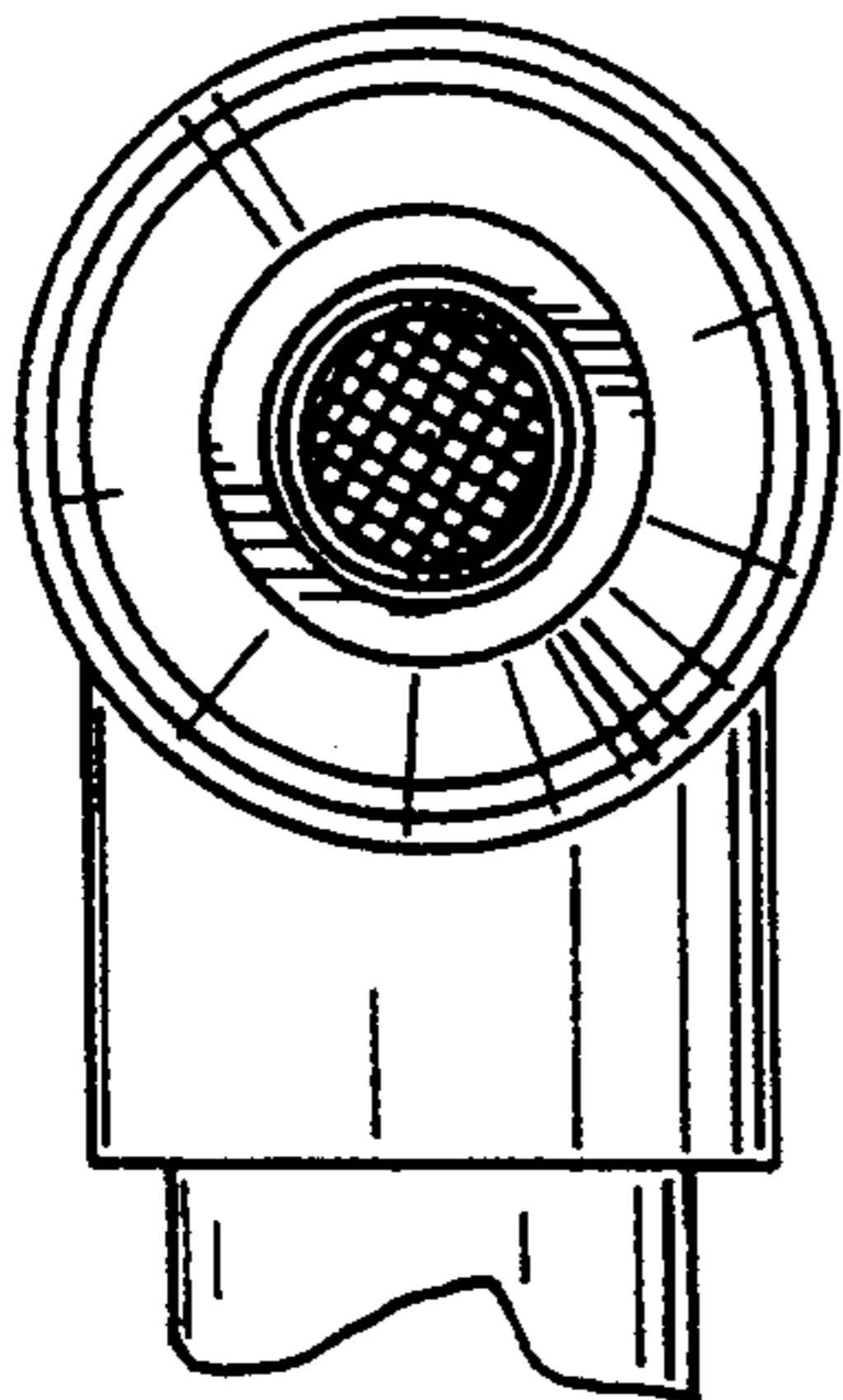

FIG. 5

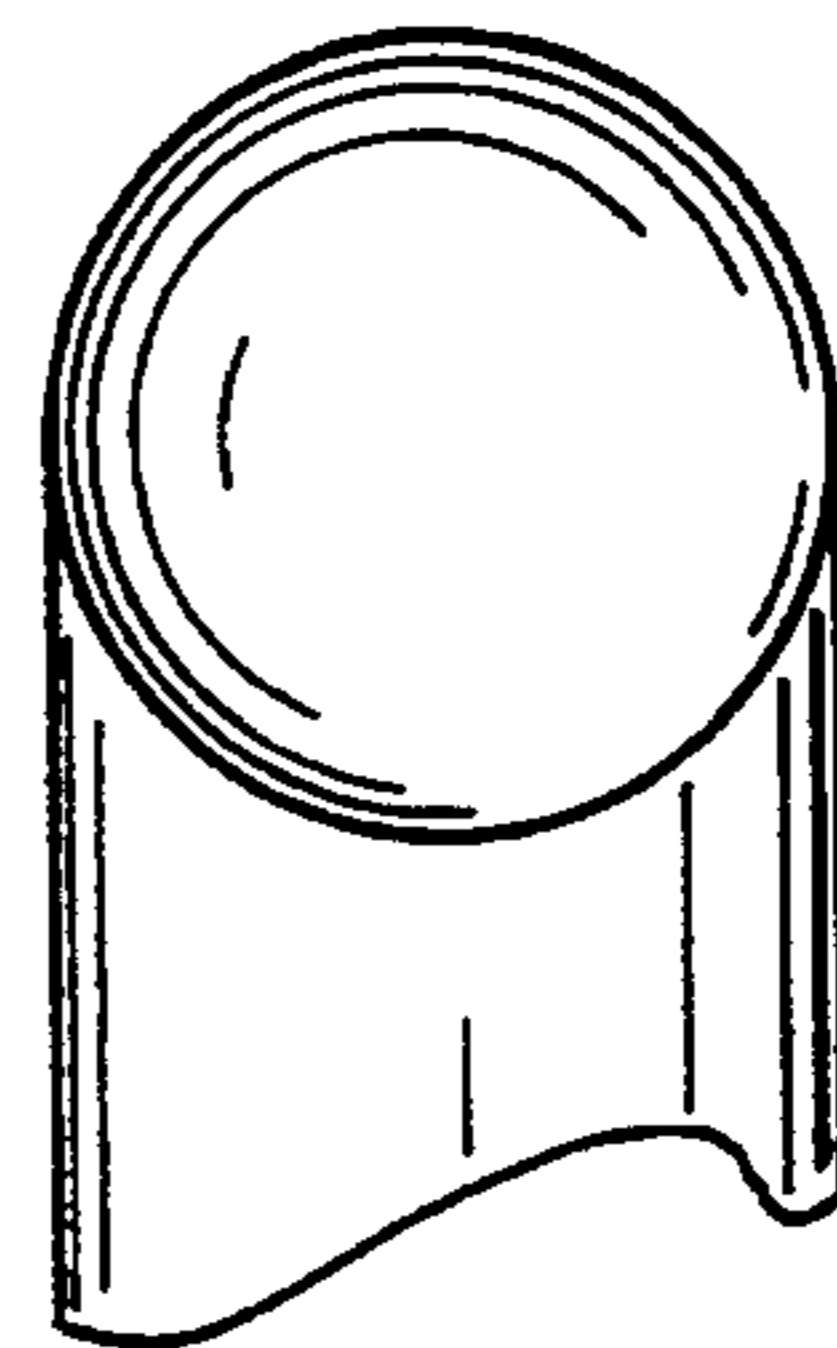

FIG. 6