



US00D352921S

United States Patent [19] Pepe

[11] Patent Number: Des. 352,921

[45] Date of Patent: ** Nov. 29, 1994

[54] **MOTORIZED SCOOTER**

[76] Inventor: **Anthony Pepe**, 207 E. 85th St., New York, N.Y. 10028

[**] Term: **14 Years**

[21] Appl. No.: **3,212**

[22] Filed: **Dec. 30, 1992**

[52] U.S. Cl. **D12/110; D21/81**

[58] Field of Search **180/181, 216; 280/87.04; D12/110; D21/81**

[56] **References Cited**

U.S. PATENT DOCUMENTS

D. 313,633	1/1991	Cummings	D21/81
D. 317,954	7/1991	Cohen	D21/81
D. 326,290	5/1992	Badsey	D12/110
D. 330,394	10/1992	Cohen	D12/110
4,842,091	6/1989	Badsey	180/181

FOREIGN PATENT DOCUMENTS

23143 3/1992 Czechoslovakia .

Primary Examiner—James M. Gandy

Assistant Examiner—M. Brown

Attorney, Agent, or Firm—Lackenbach Siegel Marzullo Aronson & Greenspan

[57] **CLAIM**

The ornamental design for a motorized scooter, as shown and described.

DESCRIPTION

FIG. 1 is a front and left side perspective view of a motorized scooter showing my new design, it being understood that the broken lines are shown for illustrative purposes only and form no part of the claimed design;

FIG. 2 is a top plan view thereof;

FIG. 3 is a front view thereof, the steering handlebar is shown broken away for convenience of illustration;

FIG. 4 is a rear view thereof, the steering handlebar is shown broken away for convenience of illustration;

FIG. 5 is a right side view thereof; and,

FIG. 6 is a perspective view thereof, with the steering handlebar shown in folded down condition.

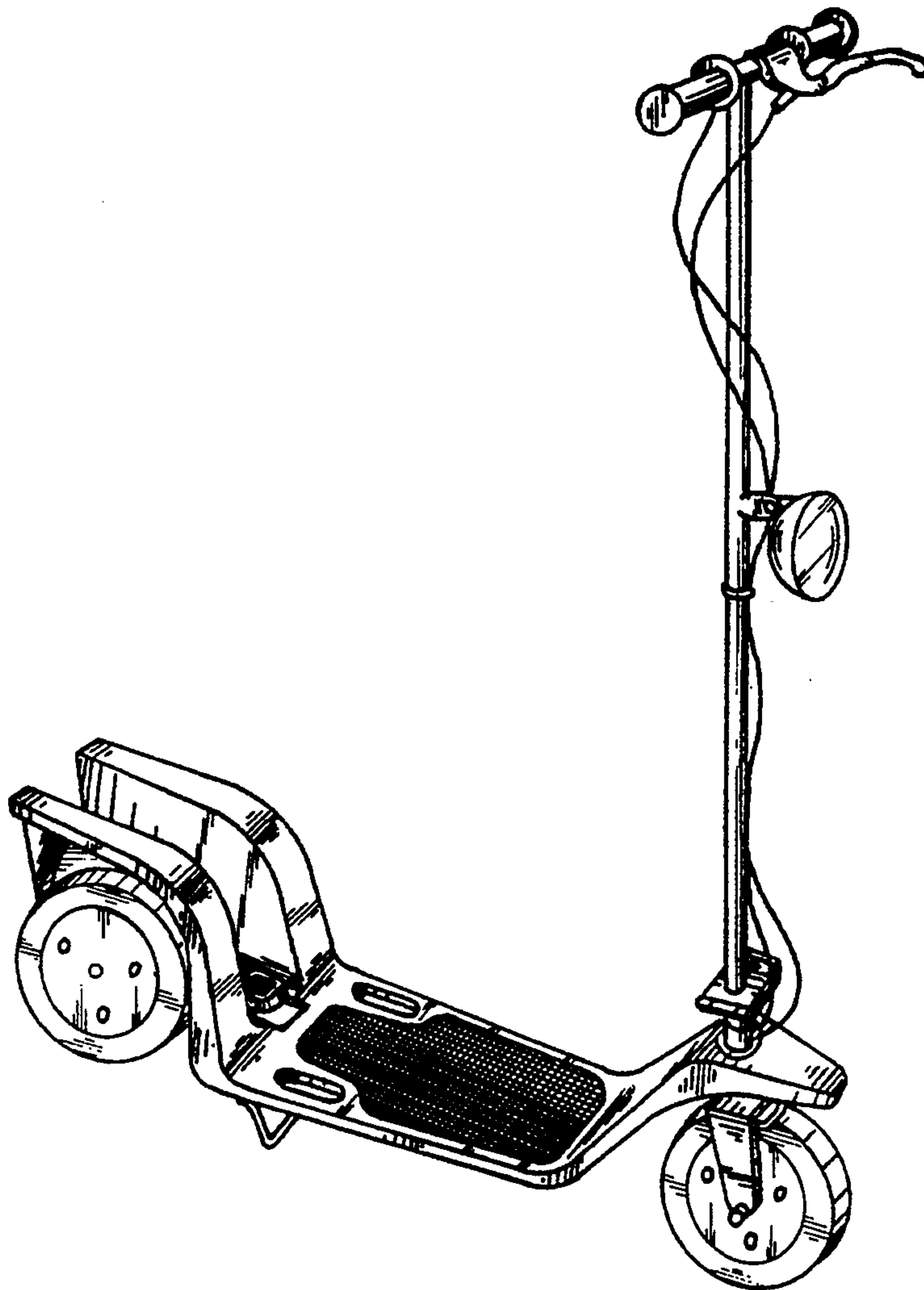

FIG. 1

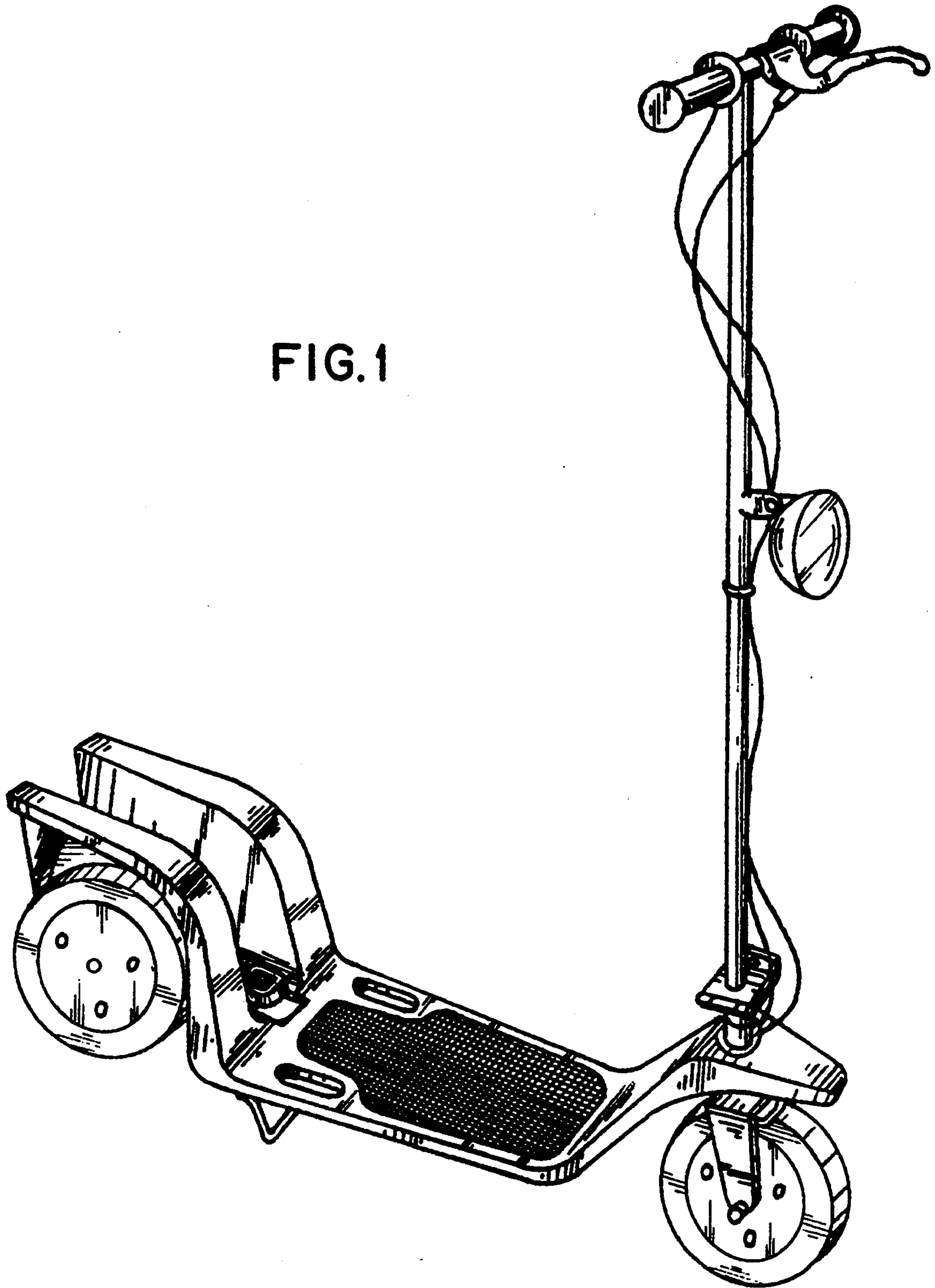
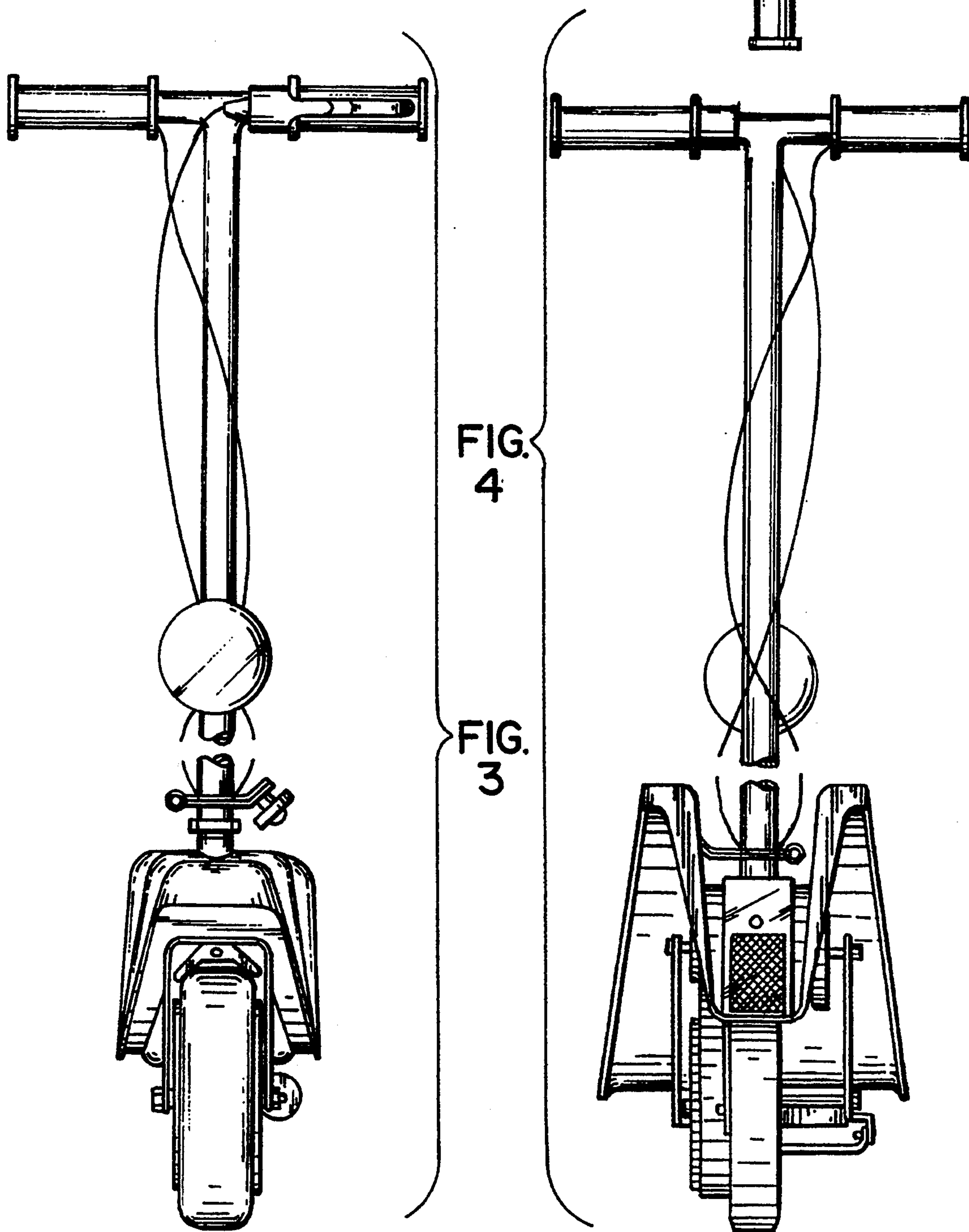
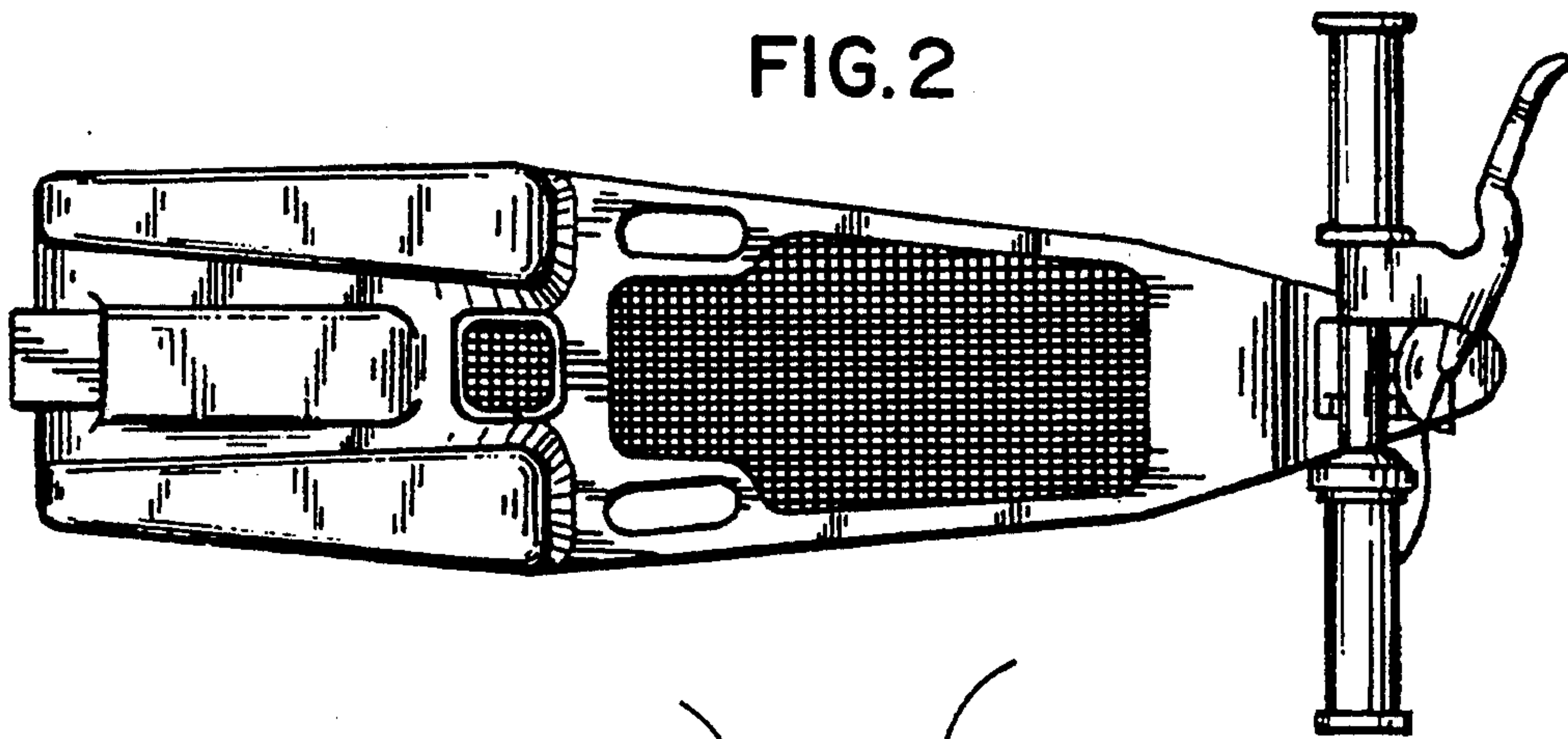

FIG. 2



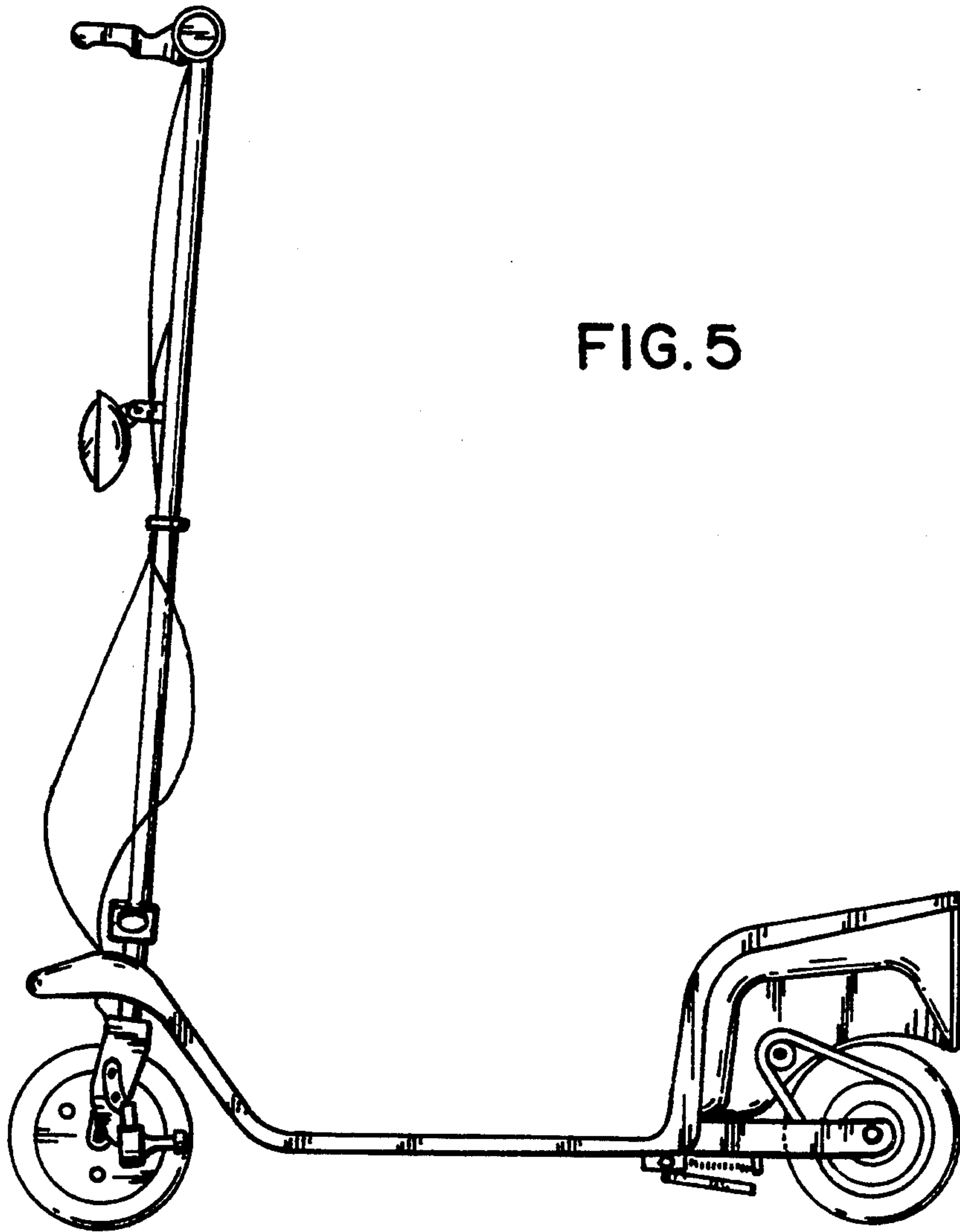

FIG. 5

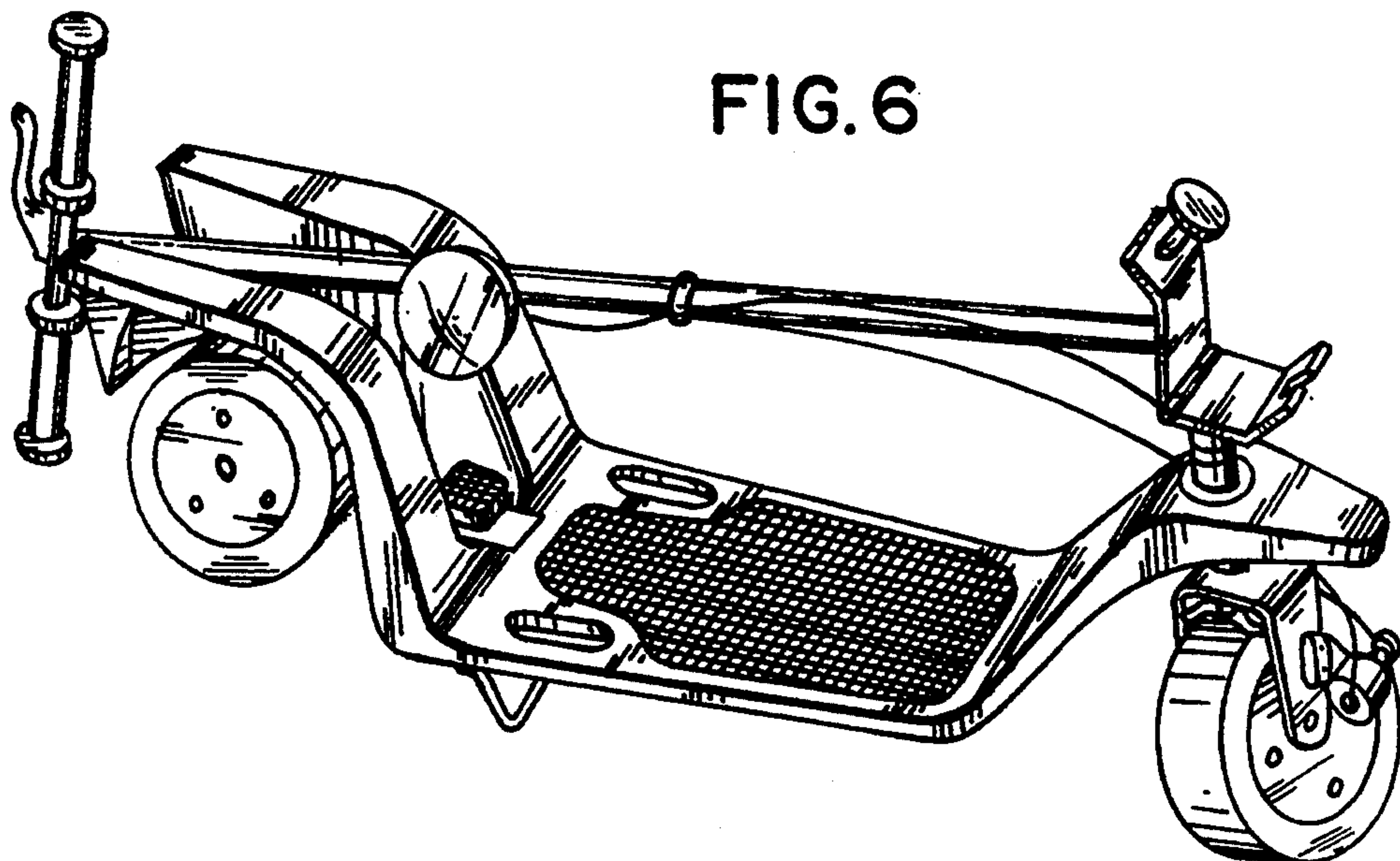

FIG. 6