



US00D352774S

# United States Patent [19]

Godfrey et al.

[11] Patent Number: **Des. 352,774**

[45] Date of Patent: **\*\* Nov. 22, 1994**

[54] **MARINE ENGINE COMPARTMENT HEATER**

[75] Inventors: **Jerry A. Godfrey; Steve Bell**, both of 4371-A Hwy. 78, Lilburn, Ga. 30247

[73] Assignees: **Jerry A. Godfrey; Steve Bell**, Lilburn, Ga.

[\*\*] Term: **14 Years**

[21] Appl. No.: **4,471**

[22] Filed: **Dec. 10, 1992**

[52] U.S. Cl. .... **D23/335; D23/389**

[58] Field of Search ..... 392/352, 353, 365-369, 392/383, 373, 374, 382, 370; D23/389, 370, 332, 335, 386, 385, 387, 388

[56] **References Cited**

**U.S. PATENT DOCUMENTS**

56,409 10/1920 Bakstad ..... D23/385

1,535,555	4/1925	Thornton, Jr. ....	392/370
1,555,666	9/1925	Hartwig .....	392/370
1,582,684	4/1926	Hartwig .....	392/353
2,706,241	4/1955	Granger, Jr. ....	392/370

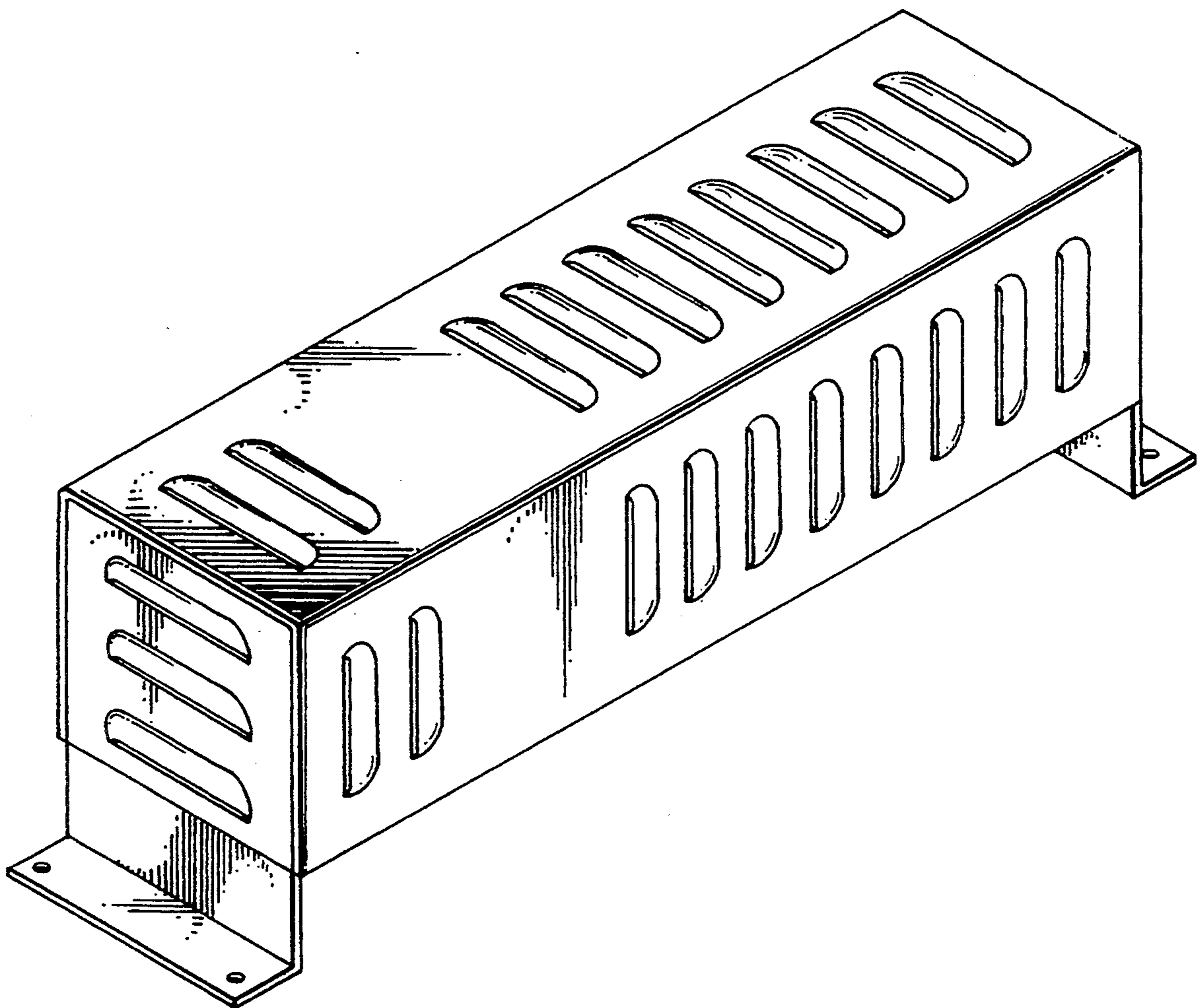
*Primary Examiner*—Lisa P. Lichtenstein  
*Attorney, Agent, or Firm*—James A. Hinkle

[57] **CLAIM**

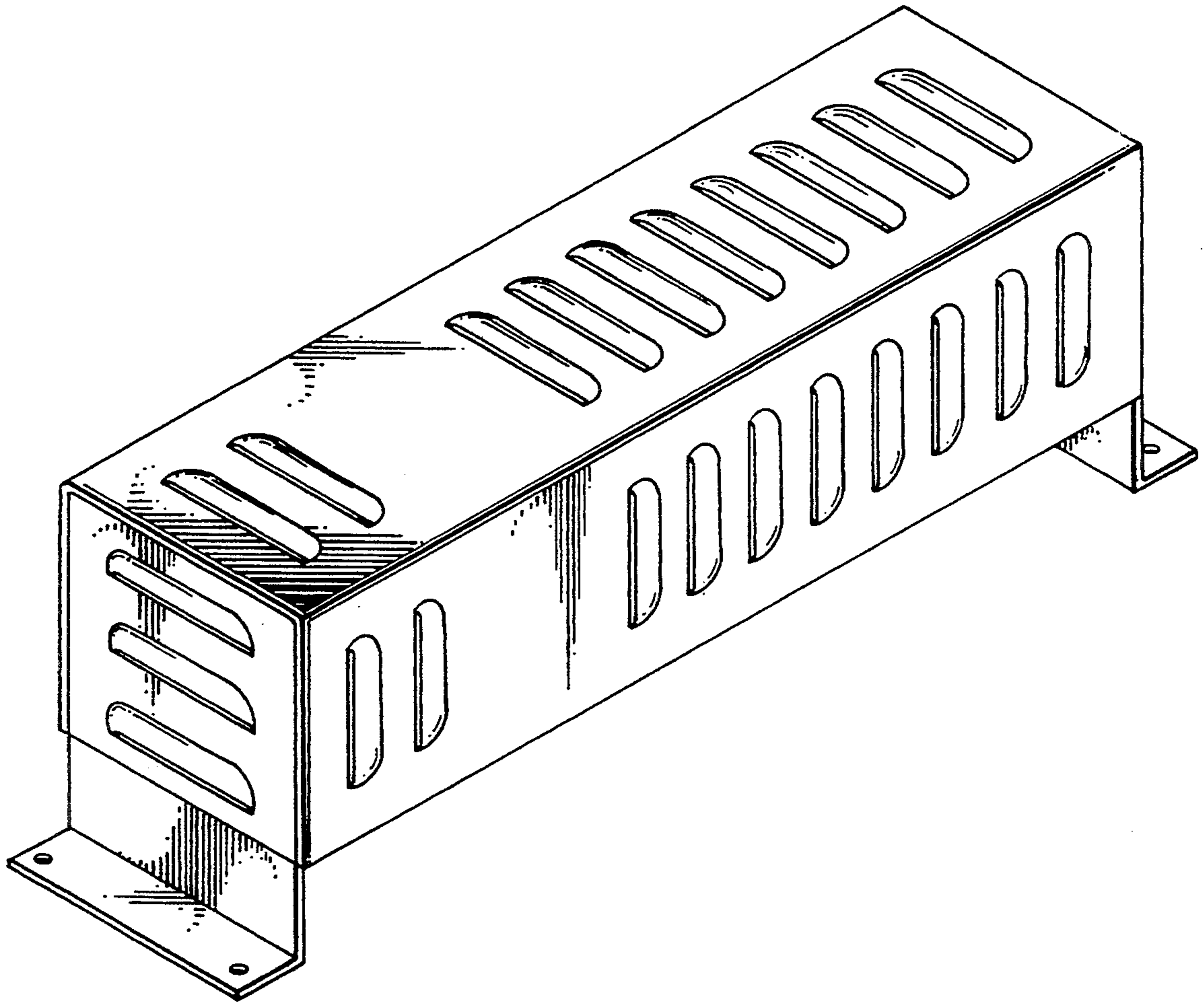
The ornamental design for a marine engine compartment heater, as shown.

**DESCRIPTION**

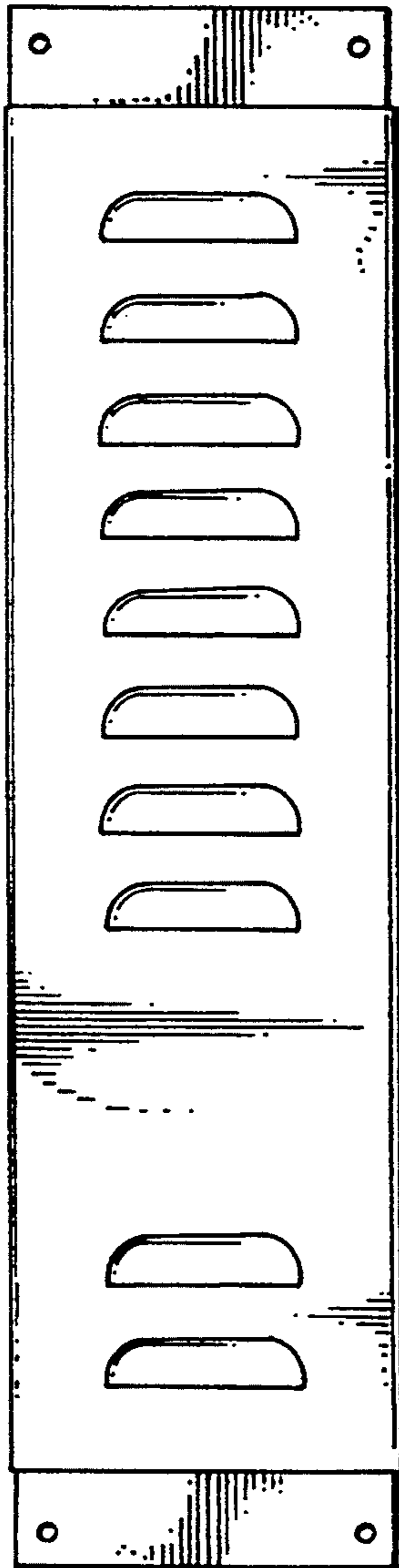
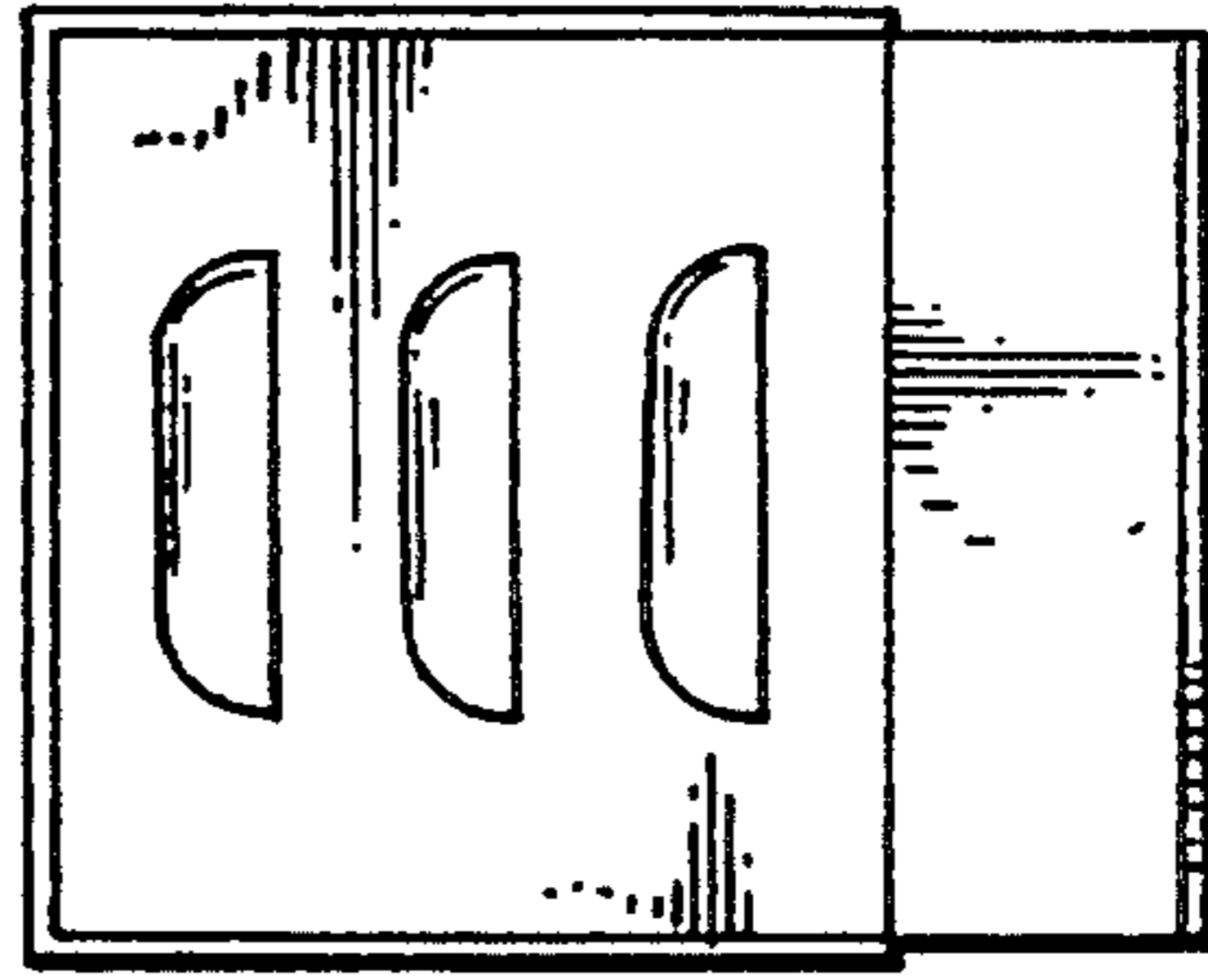
FIG. 1 is a perspective view of a marine engine compartment heater showing our new design; FIG. 2 is a left side elevation view thereof; FIG. 3 is a top plan view thereof; FIG. 4 is a front elevation view thereof; FIG. 5 is a bottom plan view thereof; FIG. 6 is a rear elevation view thereof; and, FIG. 7 is a right side elevation view thereof.



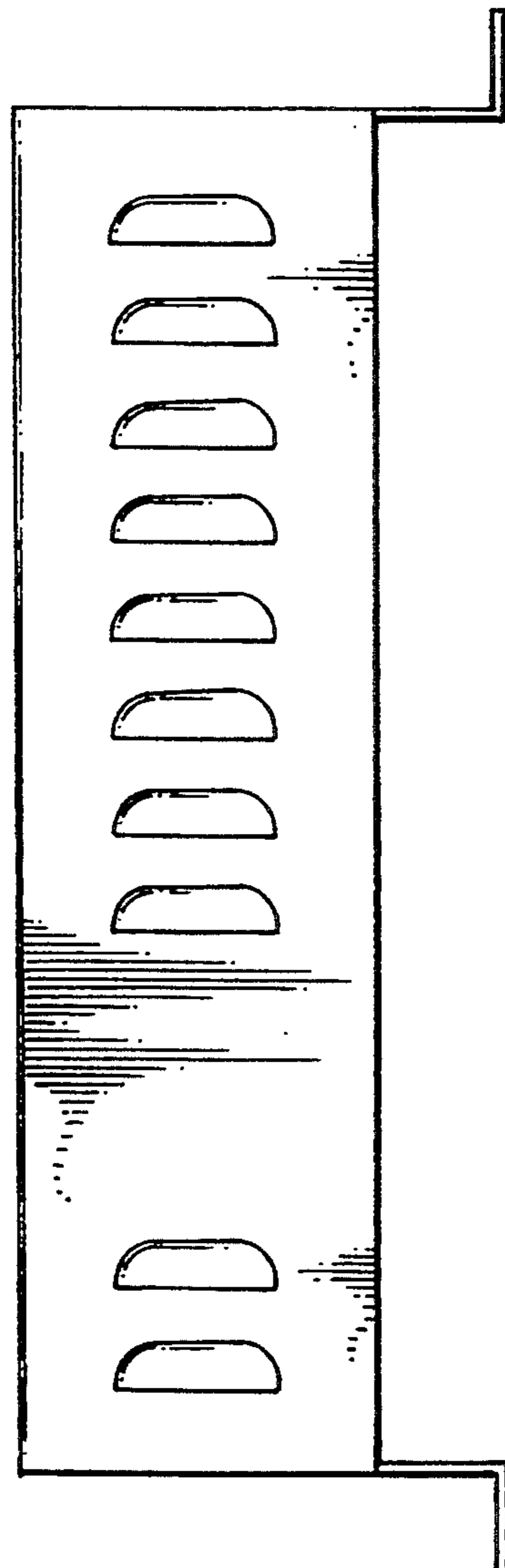
*Fig. 1*



**Fig. 2**

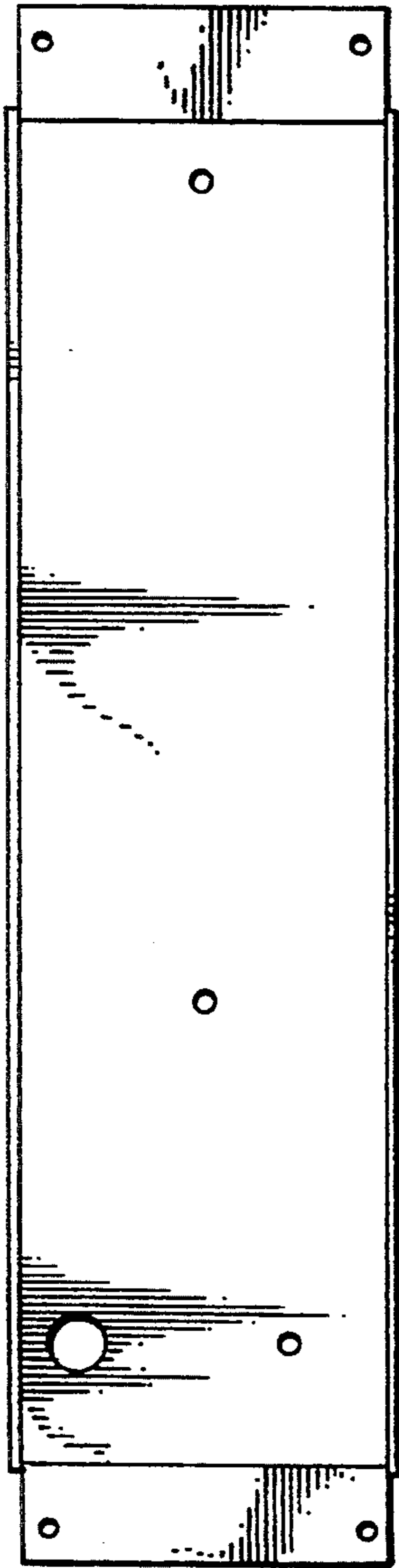


**Fig. 3**

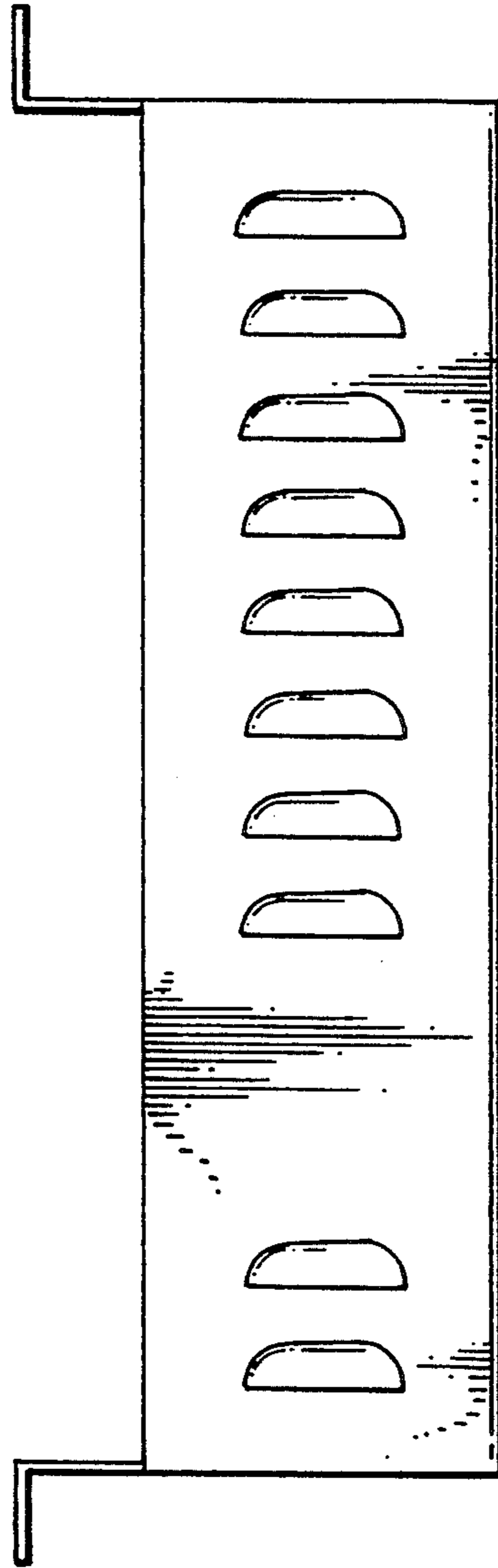


**Fig. 4**

**Fig. 5**



**Fig. 6**



**Fig. 7**

