



US00D352737S

United States Patent [19]

Roberts

[11] Patent Number: Des. 352,737

[45] Date of Patent: ** Nov. 22, 1994

[54] WINDOW MOUNTED LIGHTED SIGN FOR VEHICLES

[76] Inventor: Harold B. Roberts, 4133 Bent Willow Dr., Lilburn, Ga. 30247

[**] Term: 14 Years

[21] Appl. No.: 17,782

[22] Filed: Jan. 24, 1994

[52] U.S. Cl. D20/42

[58] Field of Search 40/1, 124, 124.1, 642, 40/643, 644, 661, 584, 591, 592, 593, 597, 617, 600; D20/10, 39, 40, 41, 42

[56] References Cited

U.S. PATENT DOCUMENTS

D. 304,737	11/1989	Mori	D20/42
D. 318,494	7/1991	Bencivenga	D20/42
D. 321,374	11/1991	Whitlock et al.	D20/42
D. 334,548	2/1994	Castello	D20/42
1,111,142	9/1914	Draycott	40/597

1,856,519 5/1932 Spears 40/597

Primary Examiner—Wallace R. Burke
Assistant Examiner—Marcus Jackson
Attorney, Agent, or Firm—James A. Hinkle

[57] CLAIM

The ornamental design for a window mounted lighted sign for vehicles, as shown.

DESCRIPTION

FIG. 1 is an enlarged perspective view of a window mounted lighted sign for vehicles showing my new design, with the broken line showing for illustrative purposes only and forming no part of the claimed design;

FIG. 2 is a top view;

FIG. 3 is a front elevational view;

FIG. 4 is a right side elevational view;

FIG. 5 is a left side elevational view;

FIG. 6 is a rear elevational view; and,

FIG. 7 is a bottom view thereof.

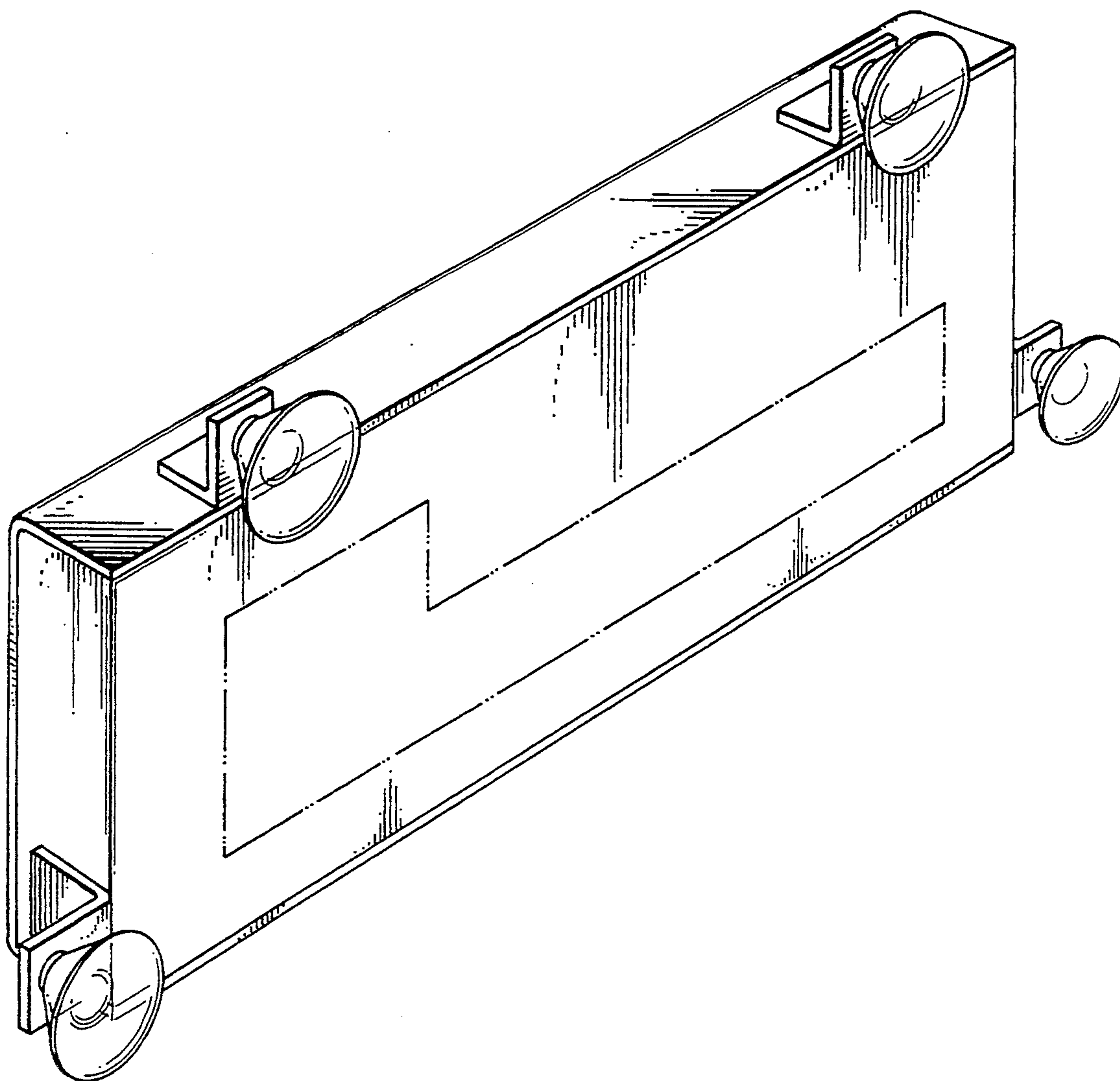

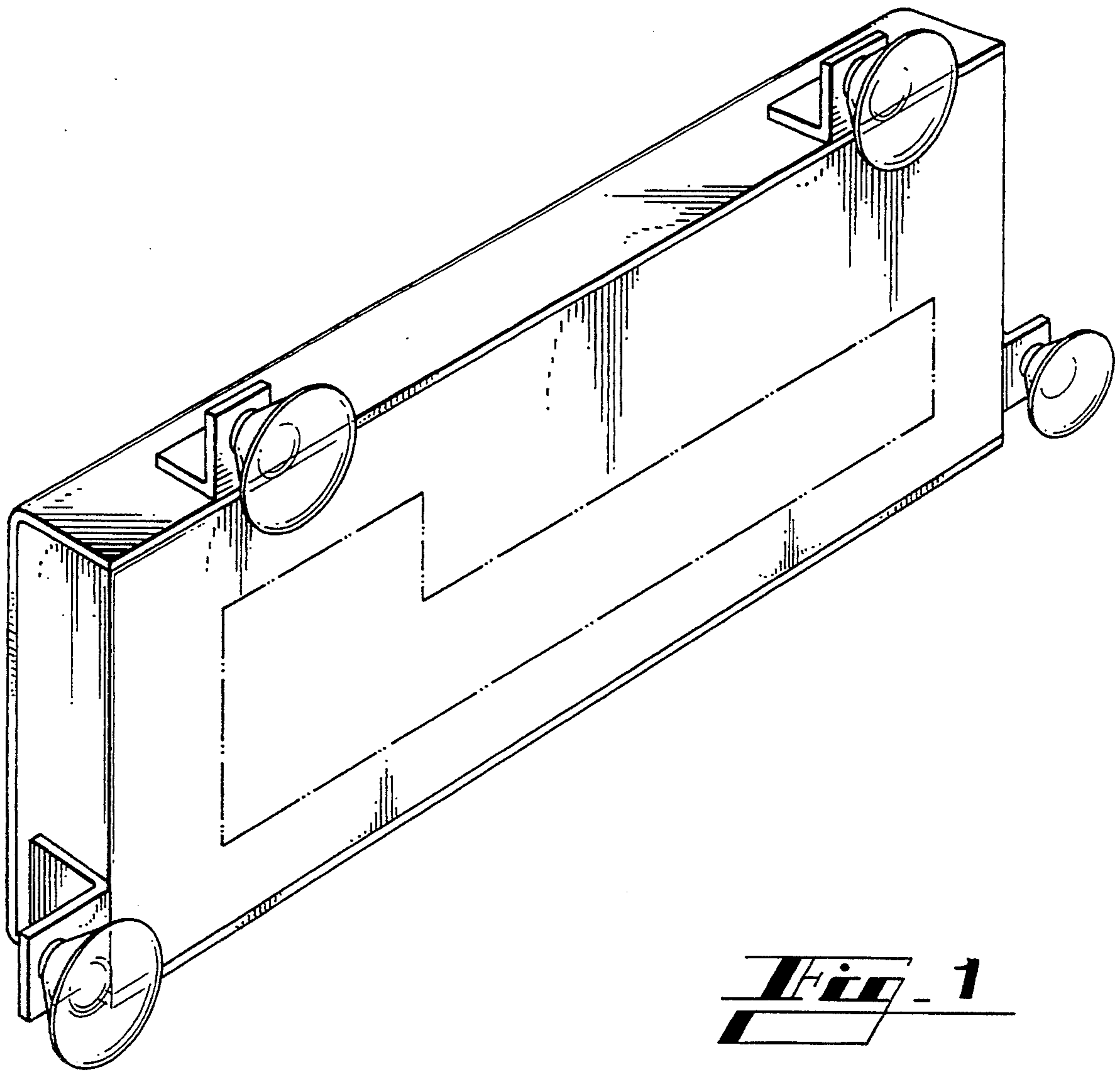

Fig. 1

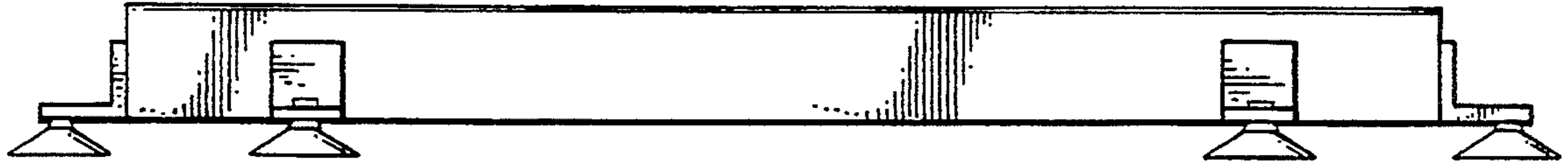

Fig. 2

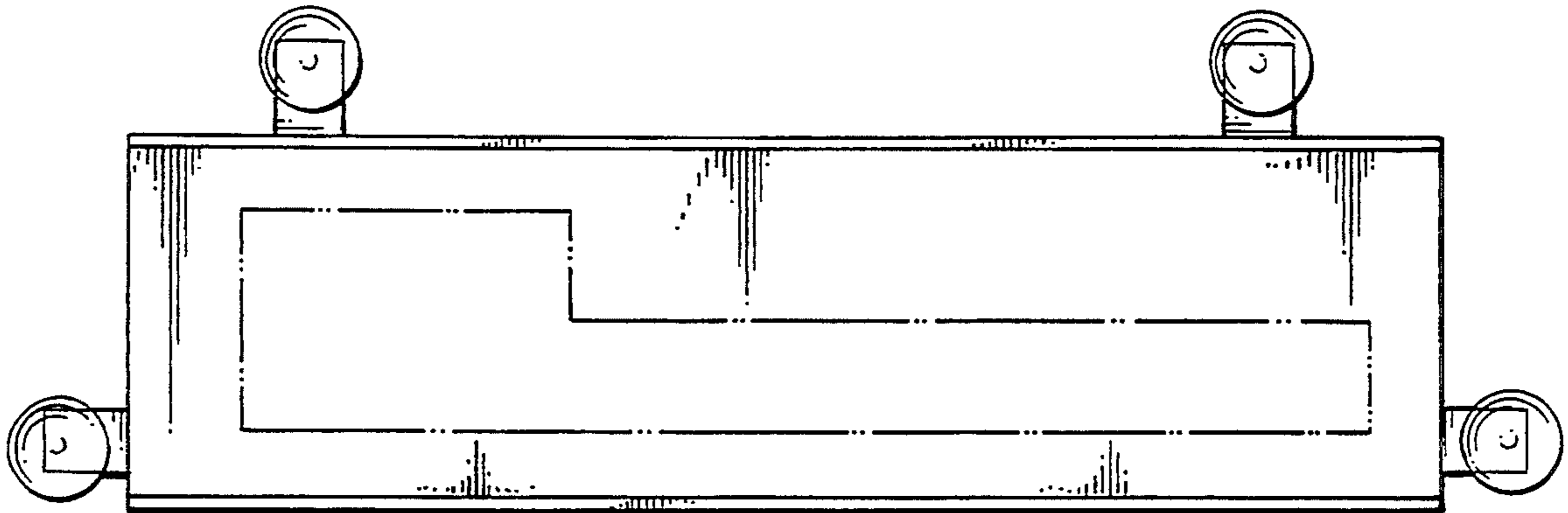

Fig. 3

Fig. 4



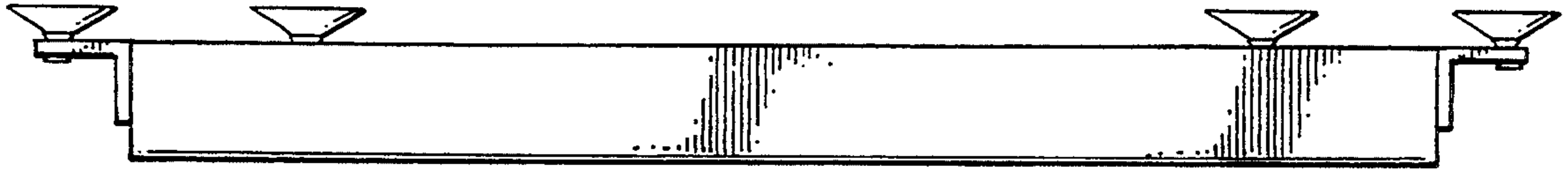

Fig. 7

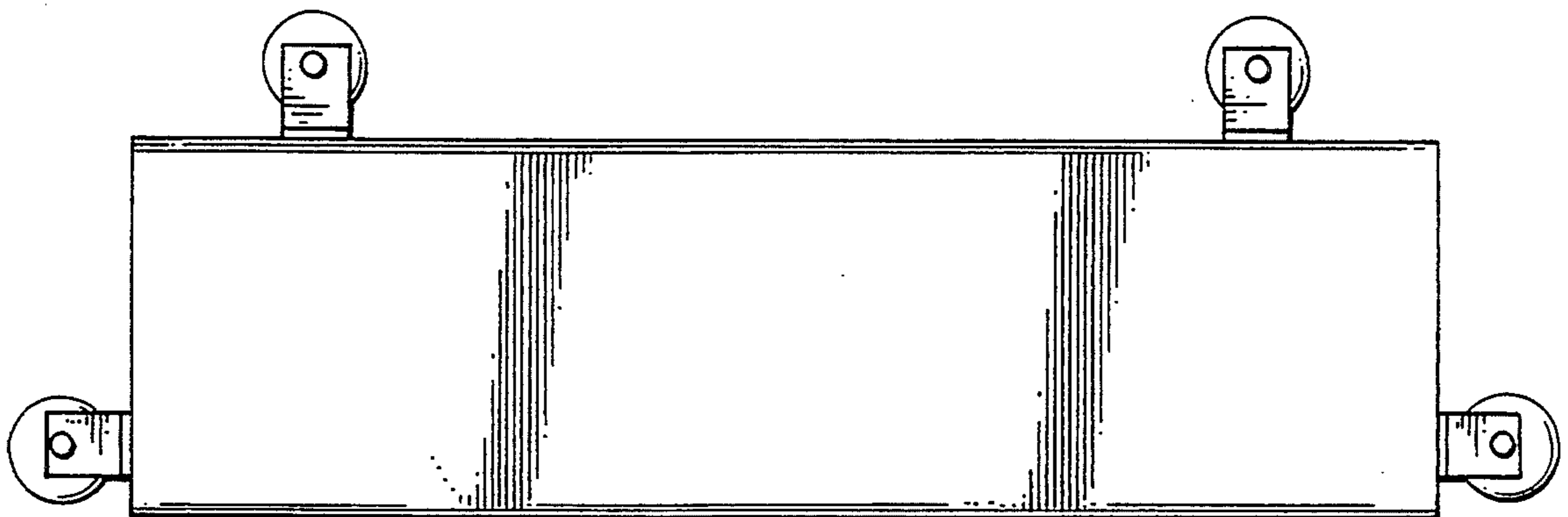

Fig. 6

Fig. 5

