



US00D352696S

United States Patent [19]
Christensen

[11] **Patent Number: Des. 352,696**
[45] **Date of Patent: ** Nov. 22, 1994**

[54] **EXTRUDED RAIL FOR A UTILITY RACK**

[56]

References Cited

U.S. PATENT DOCUMENTS

[76] **Inventor: David Christensen, 11 Moores Mill Rd., Pennington, N.J. 08534**

D. 319,810	9/1991	Stapleton et al.	D12/412
1,542,481	6/1925	Spiro	D25/125
4,811,877	3/1989	Heidman	224/324
4,988,026	1/1991	Rasor et al.	224/321
5,058,791	10/1991	Heniquez et al.	224/324

[**] **Term: 14 Years**

Primary Examiner—A. Hugo Word
Assistant Examiner—Doris Clark
Attorney, Agent, or Firm—Kenneth P. Glynn; Diane L. Ferrone

[21] **Appl. No.: 15,333**

[22] **Filed: Nov. 15, 1993**

[57]

CLAIM

The ornamental design for an extruded rail for a utility rack, as shown.

Related U.S. Application Data

DESCRIPTION

[63] Continuation-in-part of Ser. No. 110,388, Aug. 23, 1993, and a continuation-in-part of Ser. No. 64,228, May 7, 1993.

FIG. 1 is a fragmentary perspective view of an extruded rail for a utility rack showing my new design;
FIG. 2 is a front elevational view thereof;
FIG. 3 is a rear elevational view thereof;
FIG. 4 is a left side elevational view thereof;
FIG. 5 is a right side elevational view thereof;
FIG. 6 is a top plan view thereof; and,
FIG. 7 is a bottom plan view thereof.

[52] **U.S. Cl. D12/412; D25/125**
[58] **Field of Search 296/100, 3, 32, 34, 296/36, 98, 35.3, 105; 248/558, 911-912; 224/324, 321; D25/124-125; D12/412, 415, 223**

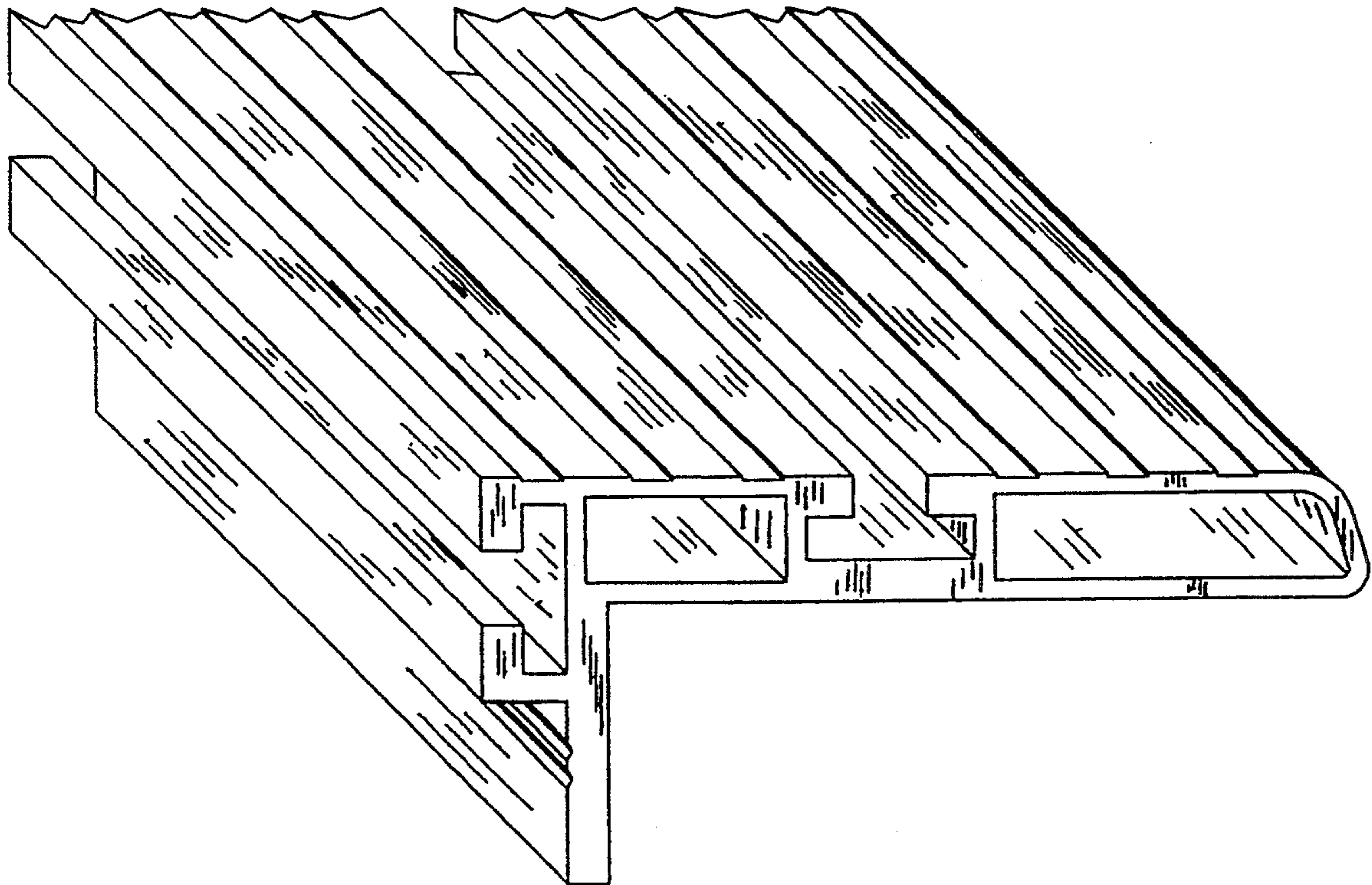

FIG-1

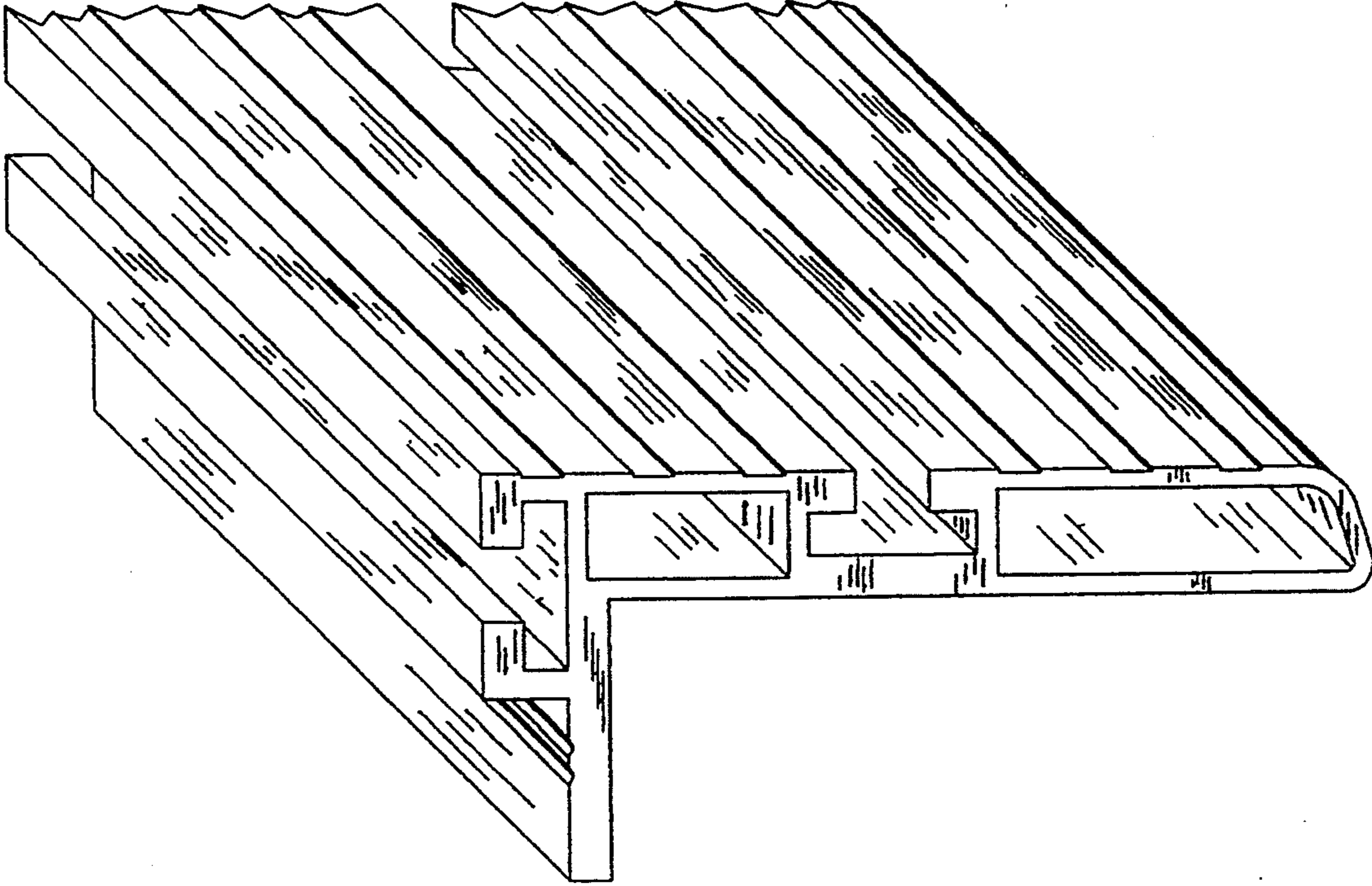

FIG-2

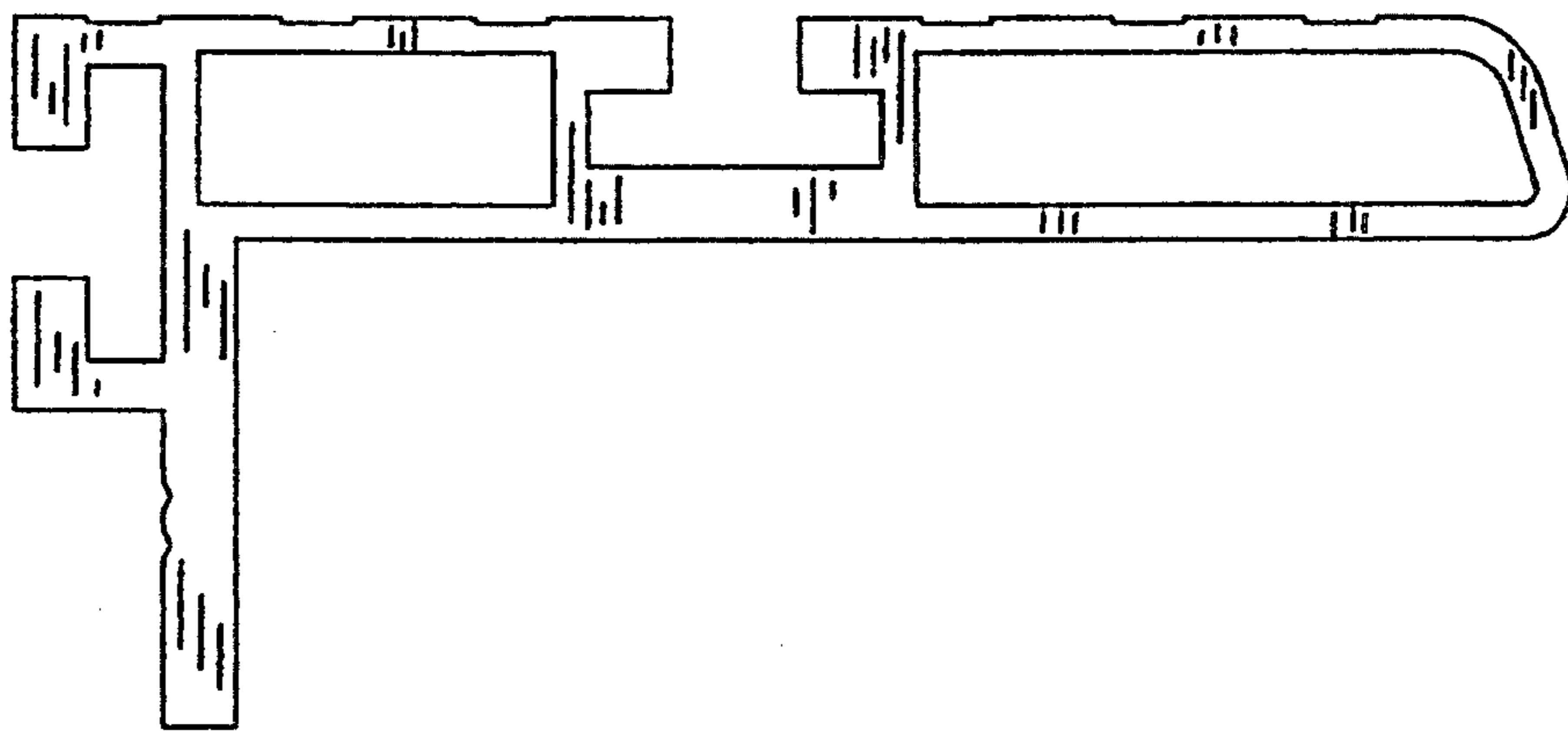

FIG-3

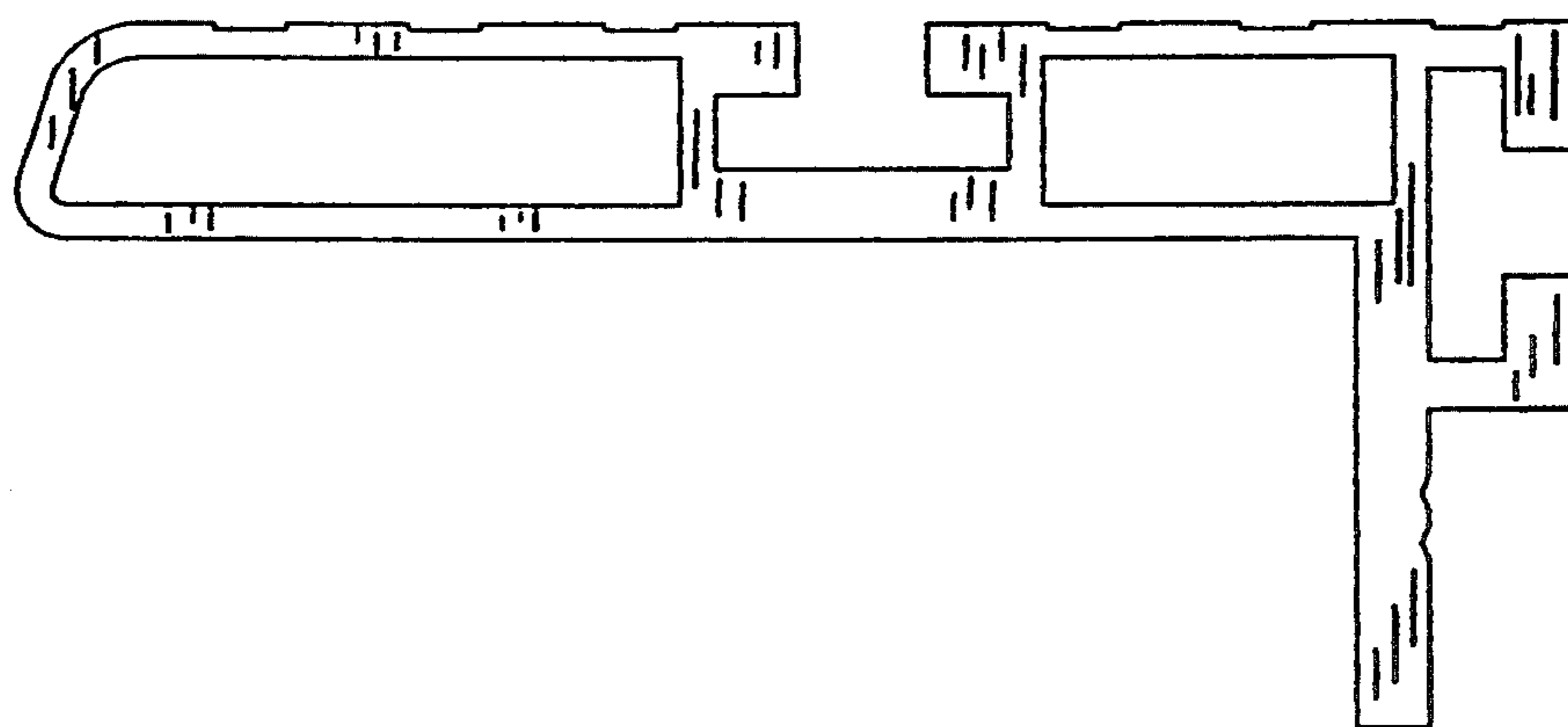

FIG-4

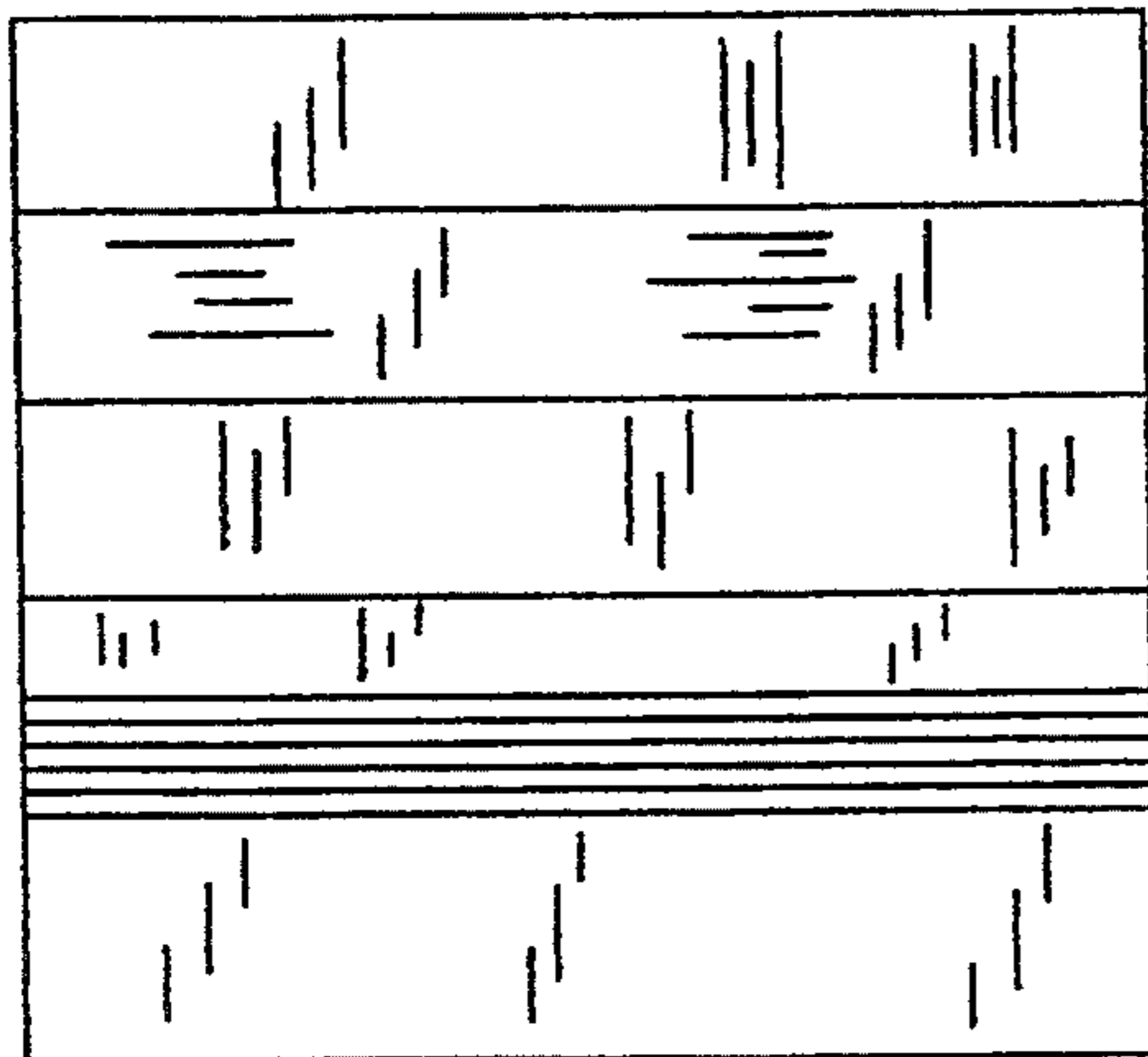

FIG-5

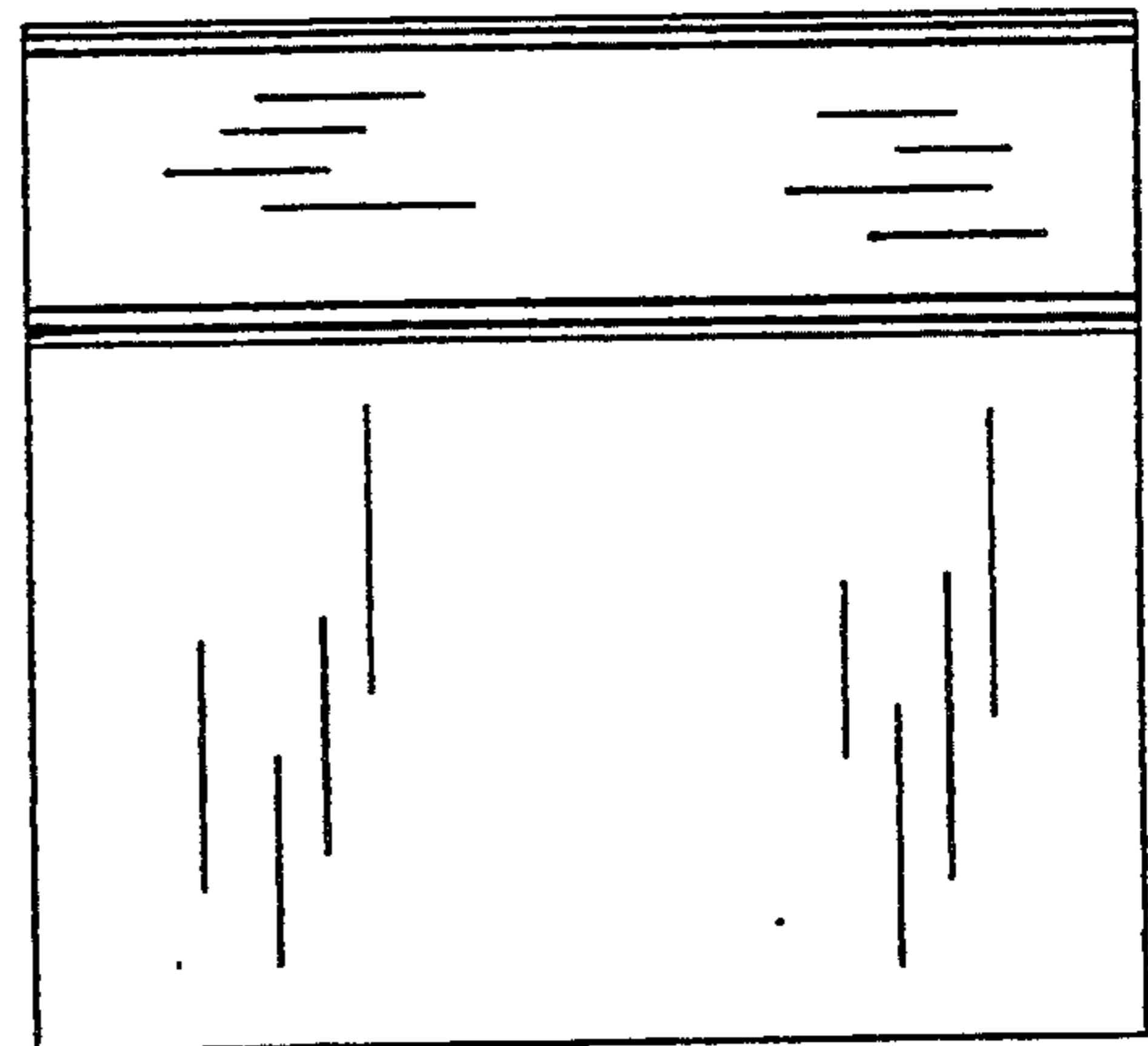

FIG-6

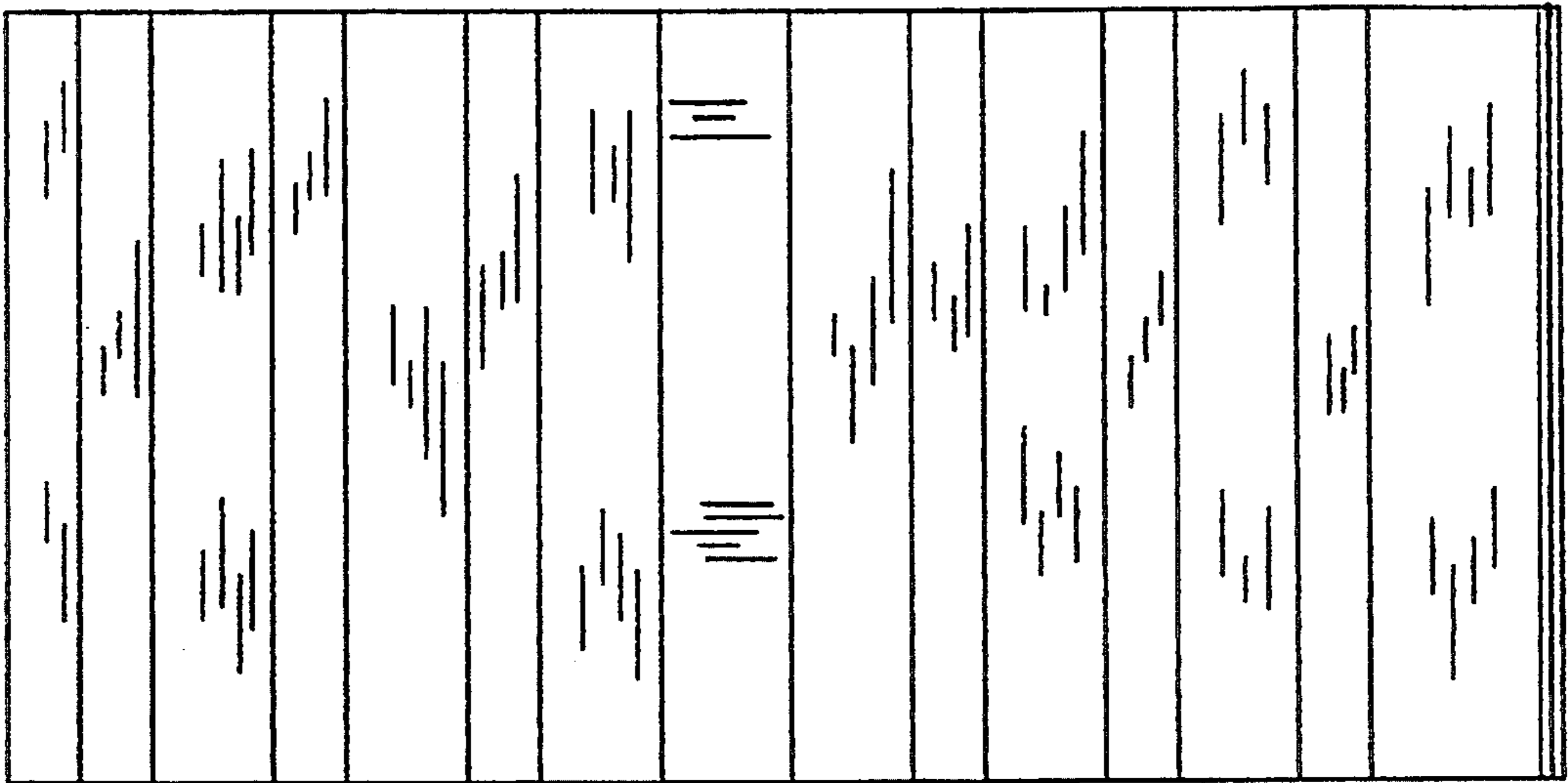

FIG-7

