



US00D352688S

United States Patent [19]
Boselli

[11] **Patent Number: Des. 352,688**
[45] **Date of Patent: ** Nov. 22, 1994**

[54] **LIGHT ALLOY WHEEL**

- [75] Inventor: **Alberto Boselli, Milan, Italy**
- [73] Assignee: **Nardi Italia SPA, Abbiate Guazzone, Italy**
- [*] Notice: **The portion of the term of this patent subsequent to Jul. 20, 2007 has been disclaimed.**
- [**] Term: **14 Years**
- [21] Appl. No.: **934,806**
- [22] Filed: **Aug. 24, 1992**
- [52] U.S. Cl. **D12/211**
- [58] Field of Search **301/63.1, 64.1, 64.7, 301/65; D12/209, 211**

[56] **References Cited**

U.S. PATENT DOCUMENTS

D. 337,563 7/1993 Boselli D12/209

OTHER PUBLICATIONS

Tire Review, Jun./1991, 1991 Custom Wheel & Tire Style Guide Supplement, p. 30, CSI Series 17, One-Piece wheel, top right side of page & C. P. Motor Sport DP Enduro 35 Wheel, third box down from top right side of page.

Tire Review, May 1990, '90 Custom Wheel & Tire Style Guide Supplement, p. 44, Hey King Wheel No. 1, second box up from bottom left side of page.

Primary Examiner—James M. Gandy
Attorney, Agent, or Firm—McAulay Fisher Nissen Goldberg & Kiel

[57] **CLAIM**

The ornamental design for a vehicle wheel, as shown and described.

DESCRIPTION

FIG. 1 is a front/side perspective view of a vehicle wheel showing my new design;
 FIG. 2 is a front elevation view of the vehicle wheel shown in FIG. 1;
 FIG. 3 is a rear elevation view of the vehicle wheel shown in FIG. 1;
 FIG. 4 is a side view of the vehicle wheel shown in FIG. 1.
 FIG. 5 is a sectional view of the vehicle wheel shown in FIG. 1 taken about line 5—5 of FIG. 2;
 FIG. 6 is a front/side perspective view of a vehicle wheel showing a second embodiment of my new design;
 FIG. 7 is a front elevation view of the vehicle wheel shown in FIG. 6;
 FIG. 8 is a rear elevation view of the vehicle wheel shown in FIG. 6;
 FIG. 9 is a side view of the vehicle wheel shown in FIG. 6;
 FIG. 10 is a sectional view of the vehicle wheel shown in FIG. 6 taken about line 10—10 of FIG. 7;
 FIG. 11 is a front/side perspective view of a vehicle wheel showing a third embodiment of my new design;
 FIG. 12 is a front elevation view of the vehicle wheel shown in FIG. 11;
 FIG. 13 is a rear elevation view of the vehicle wheel shown in FIG. 11;
 FIG. 14 is a side view of the vehicle wheel shown in FIG. 11;
 FIG. 15 is a sectional view of the vehicle wheel shown in FIG. 11 taken about line 15—15 of FIG. 12;
 FIG. 16 is a front/side perspective view of a vehicle wheel showing a fourth embodiment of my new design;
 FIG. 17 is a front elevation view of the vehicle wheel shown in FIG. 16;
 FIG. 18 is a rear elevation view of the vehicle wheel shown in FIG. 16;
 FIG. 19 is a side view of the vehicle wheel shown in FIG. 16; and,
 FIG. 20 is a sectional view of the vehicle wheel shown in FIG. 16 taken about line 20—20 of FIG. 17.

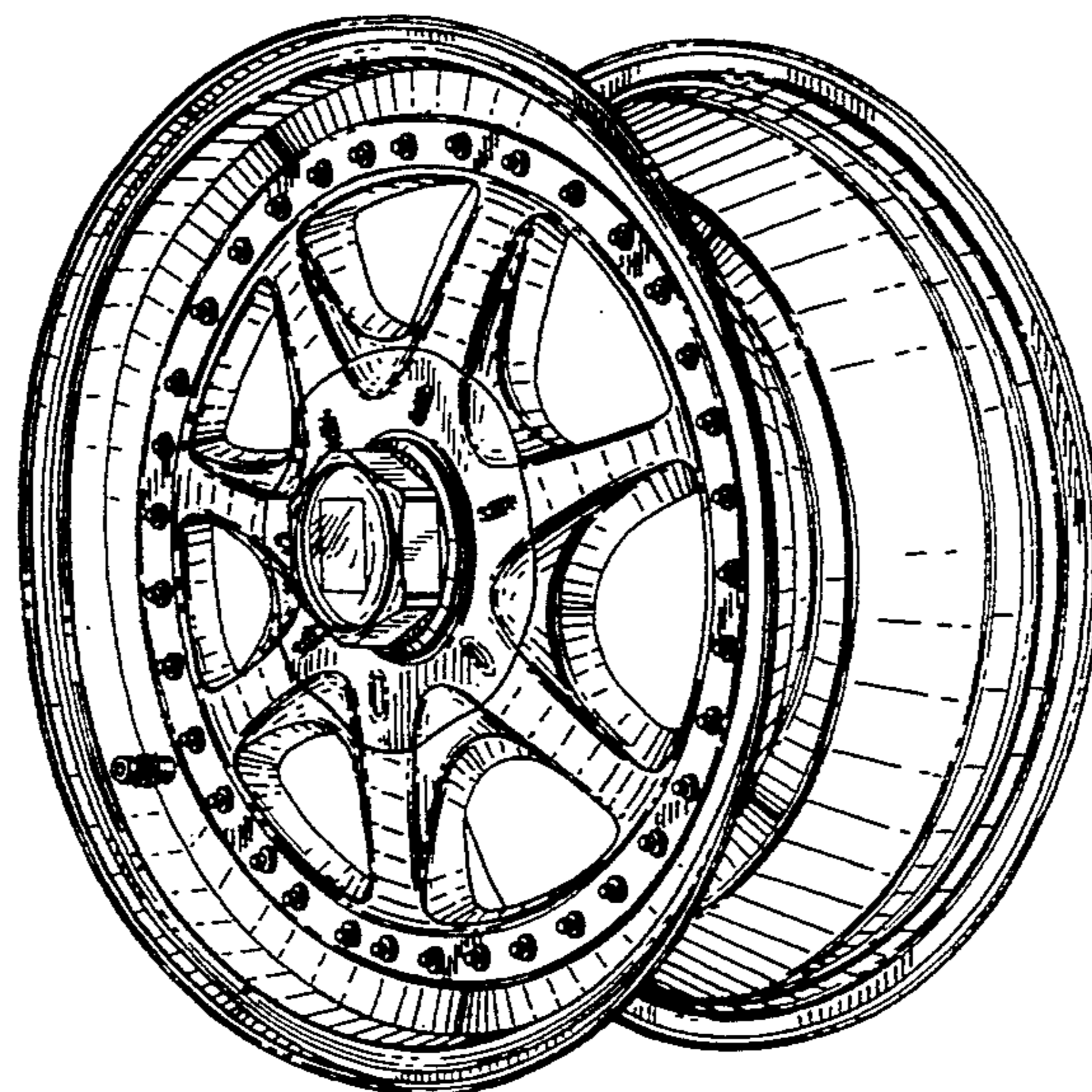

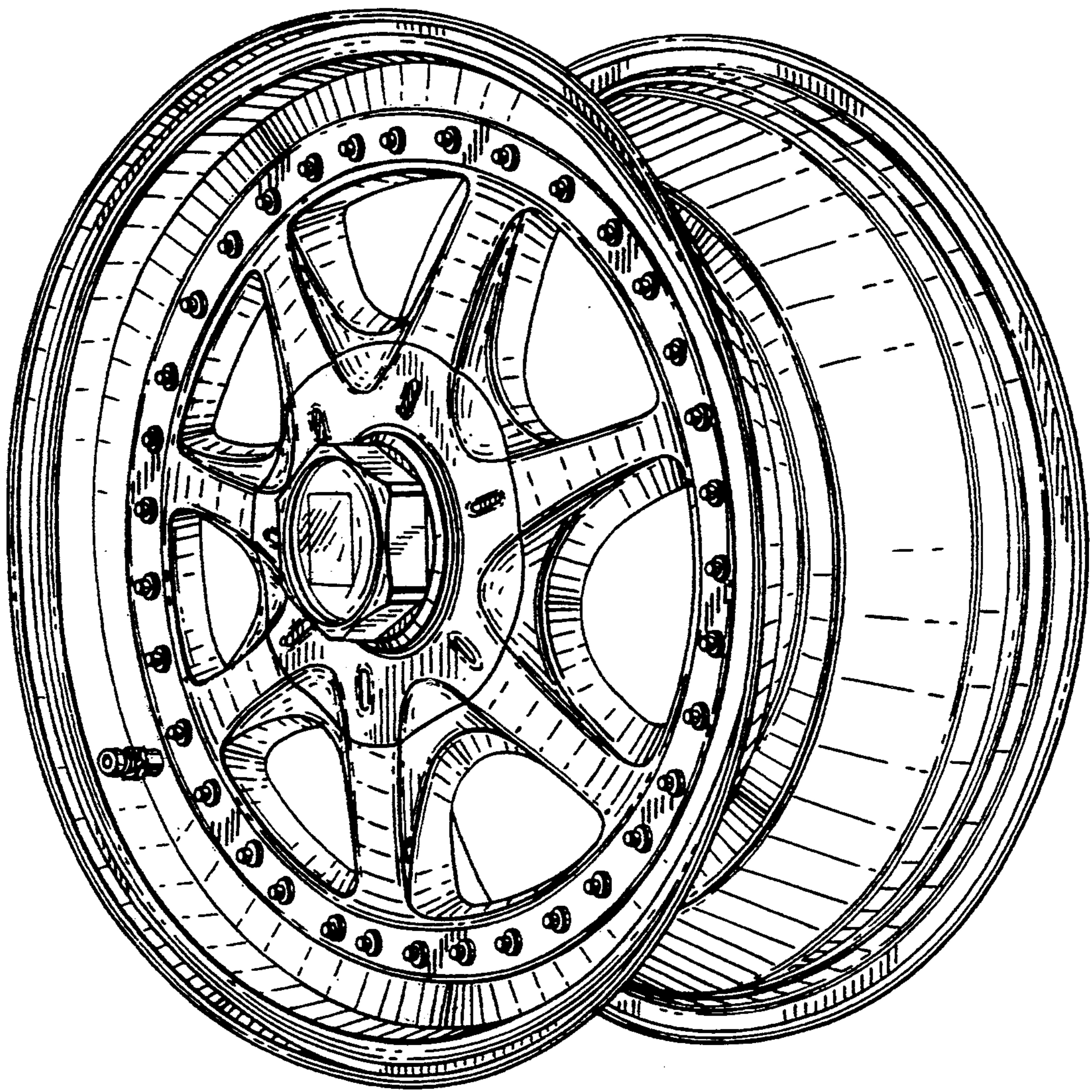

FIG. 1

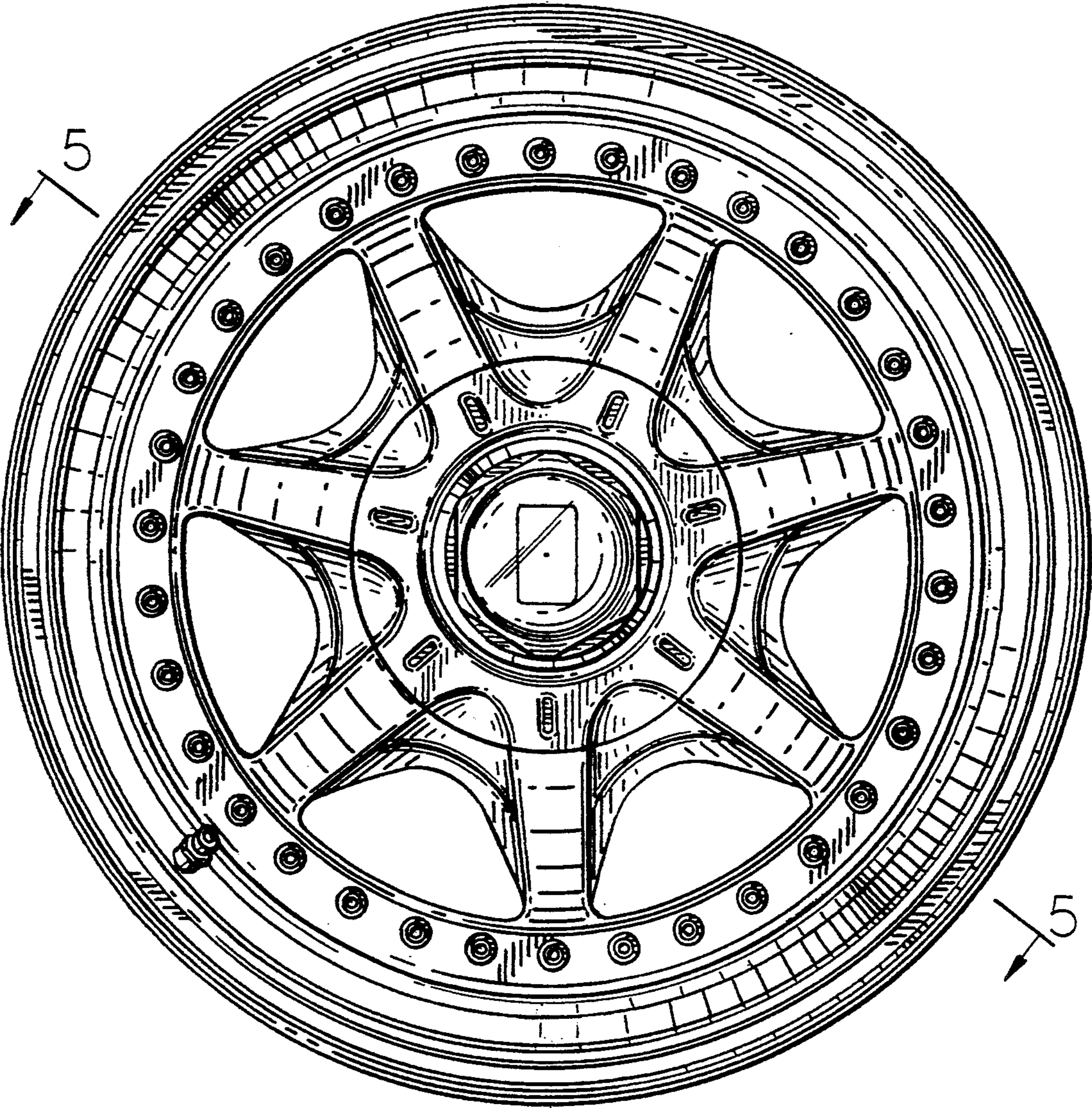

FIG 2

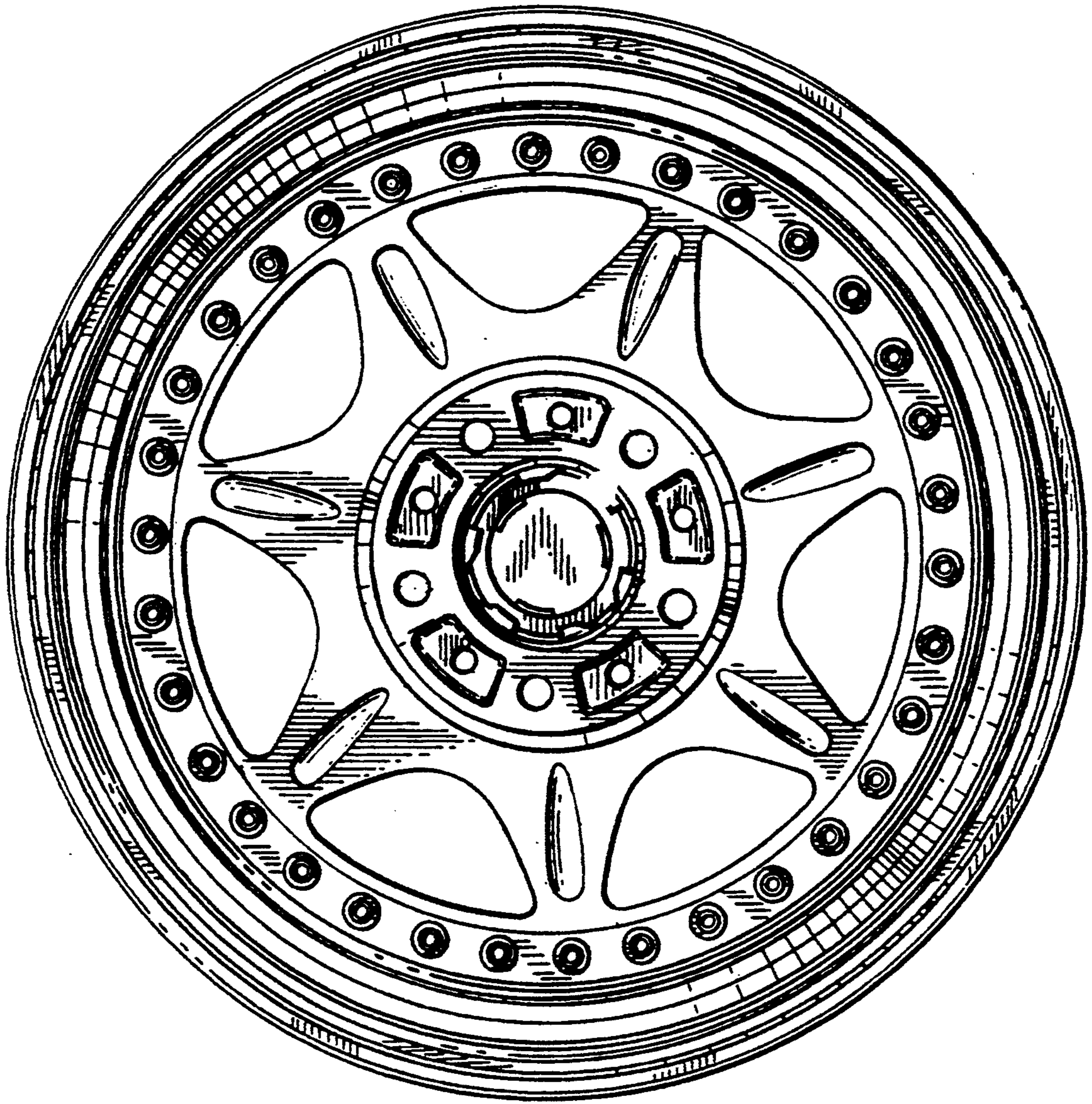

FIG. 3

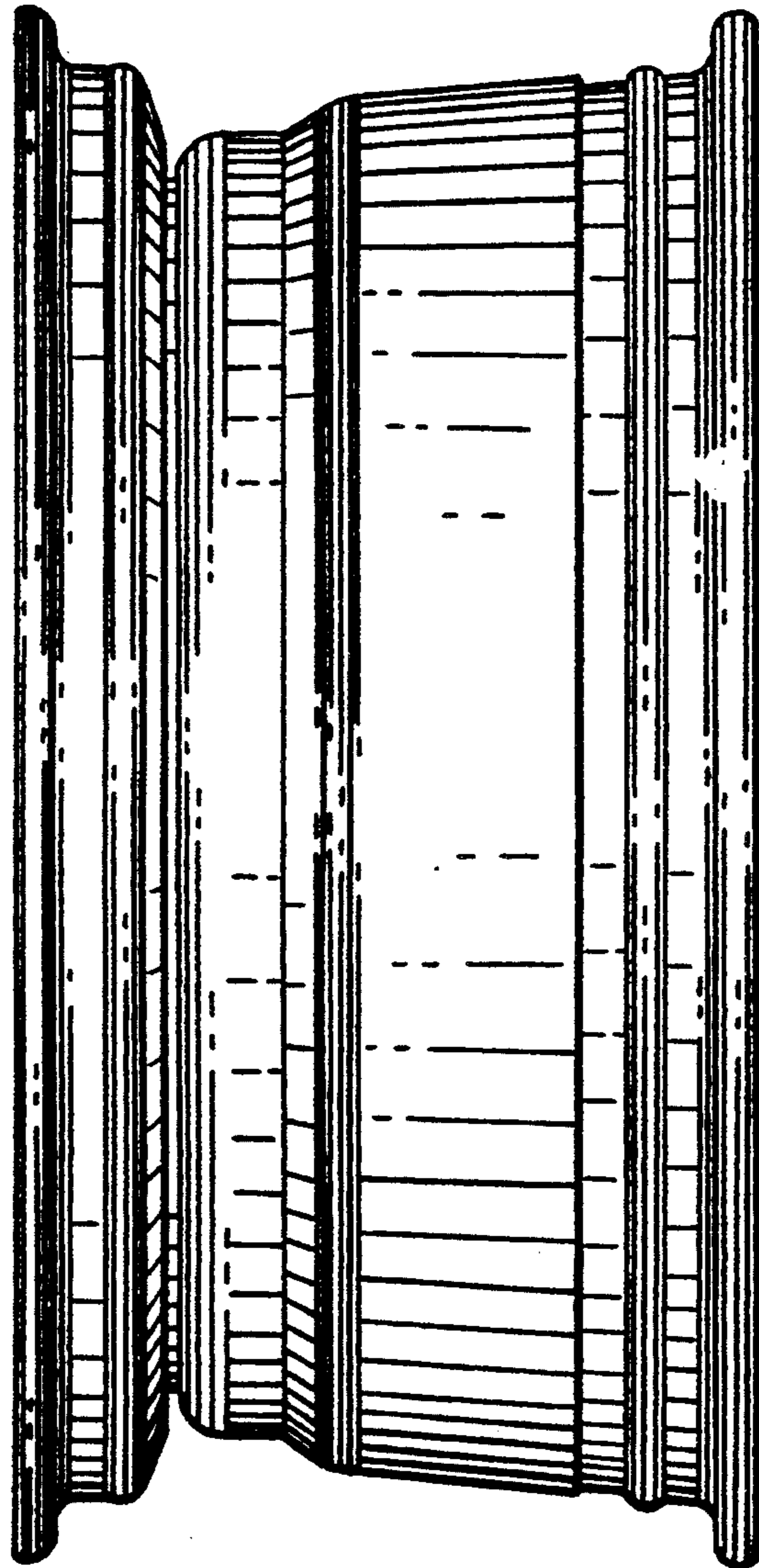

FIG. 4

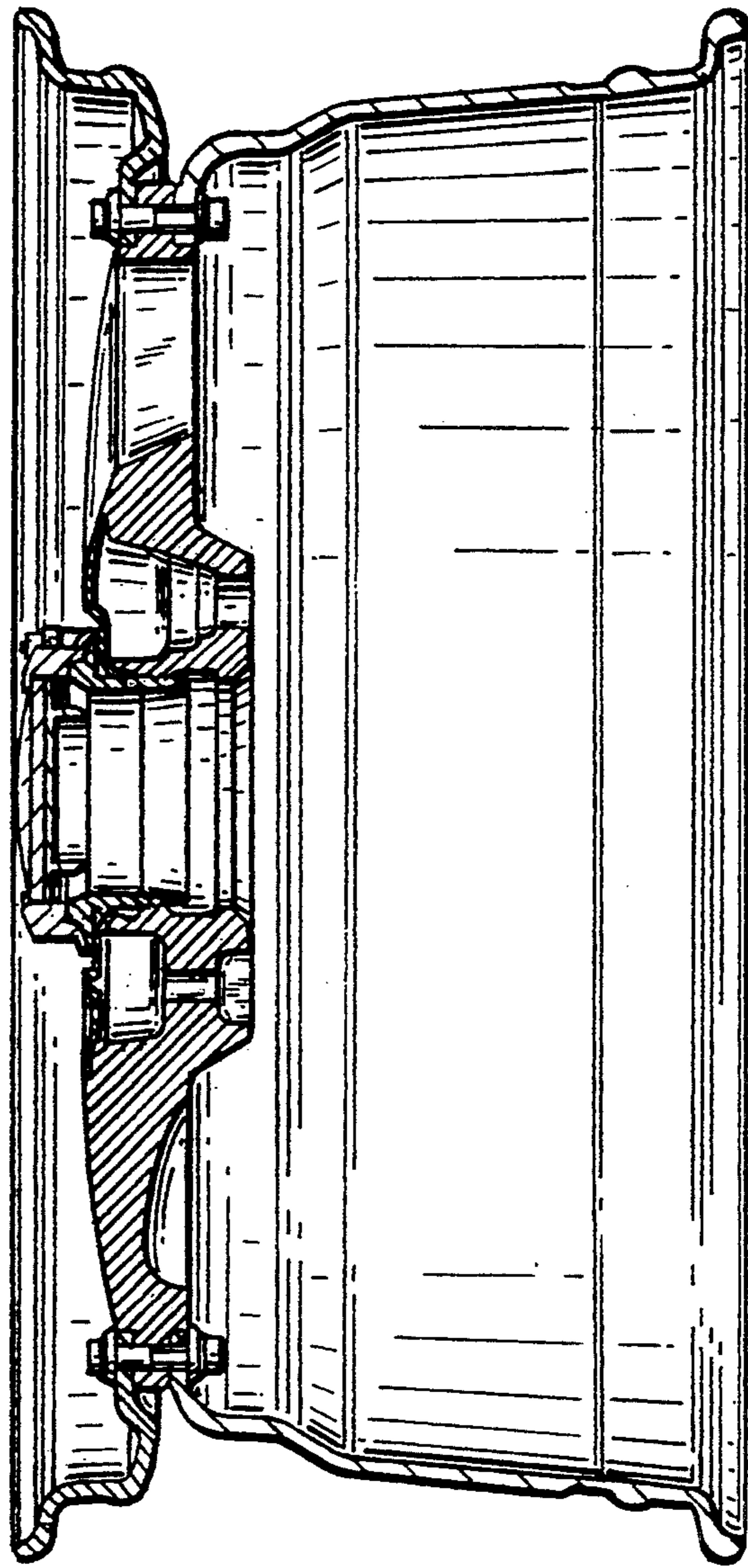

FIG. 5

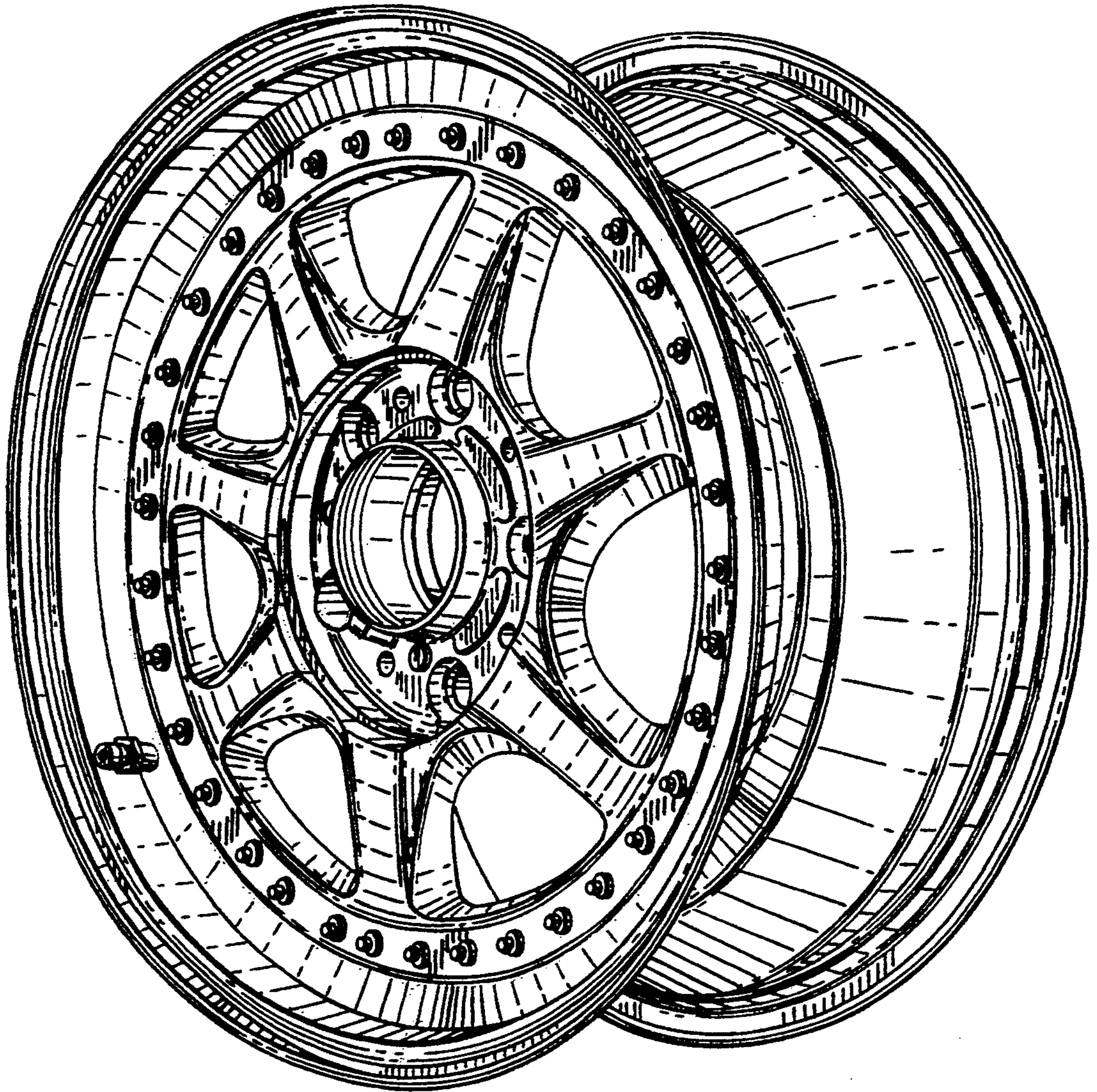

FIG. 6

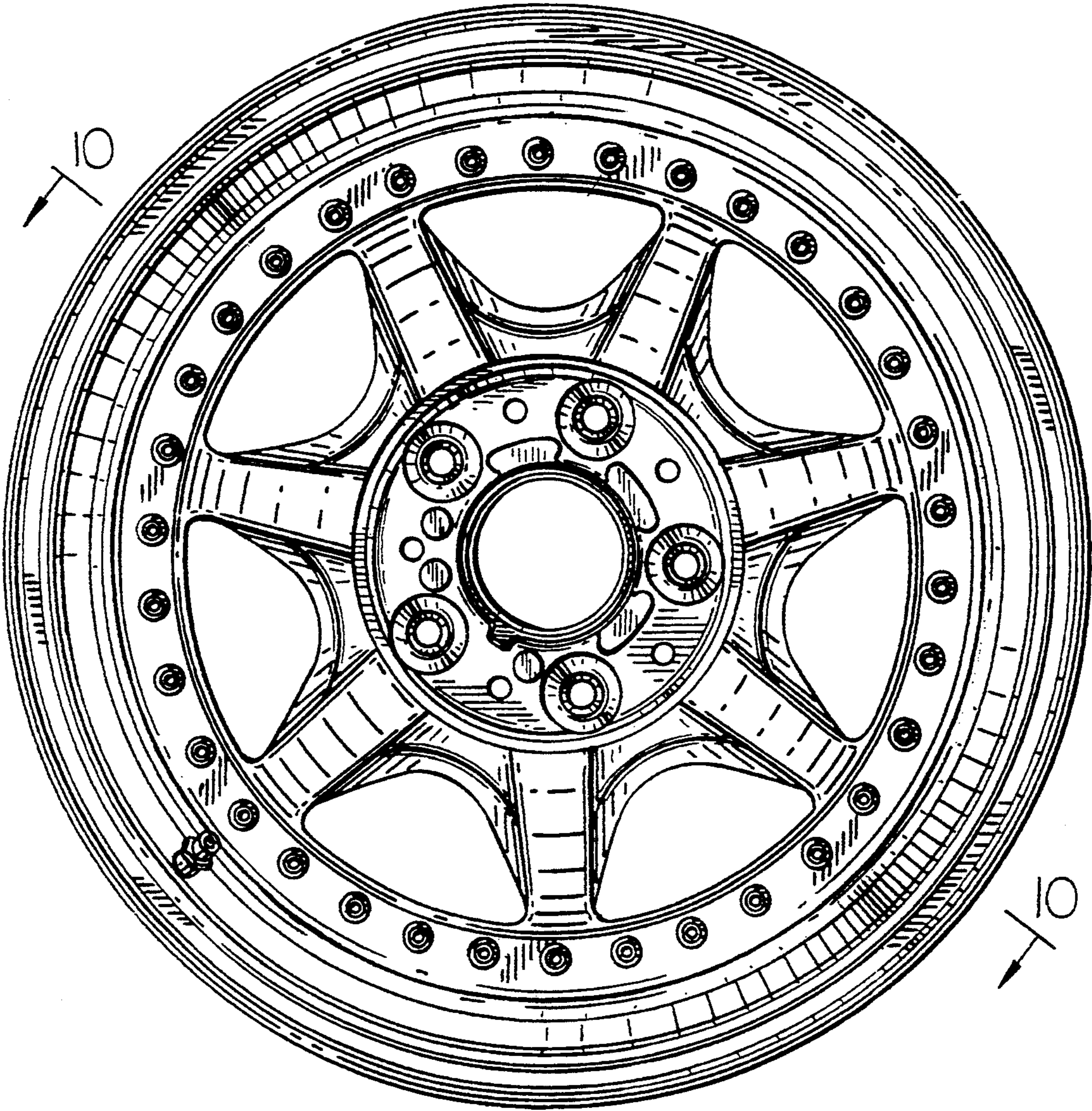

FIG. 7

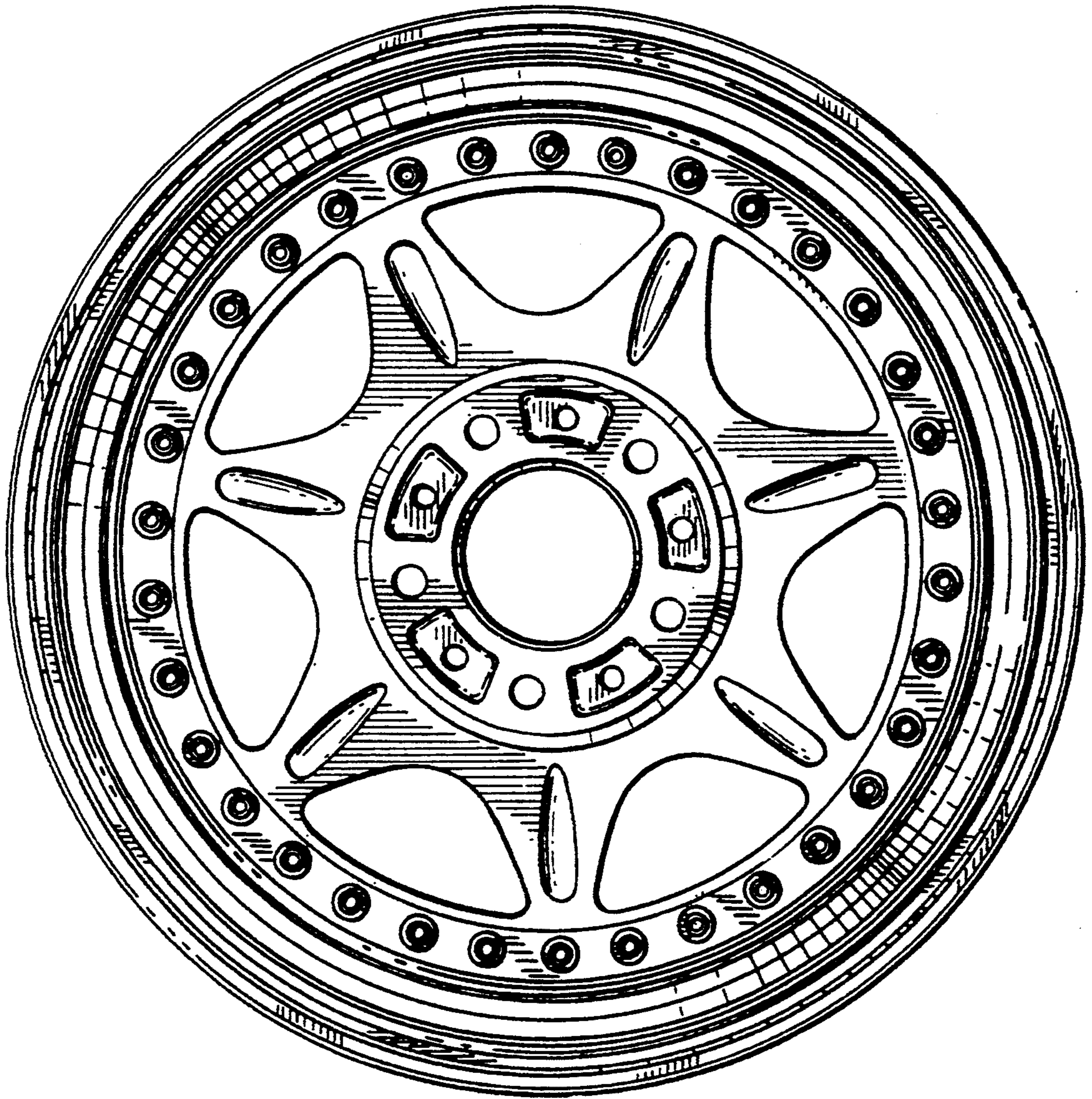

FIG. 8

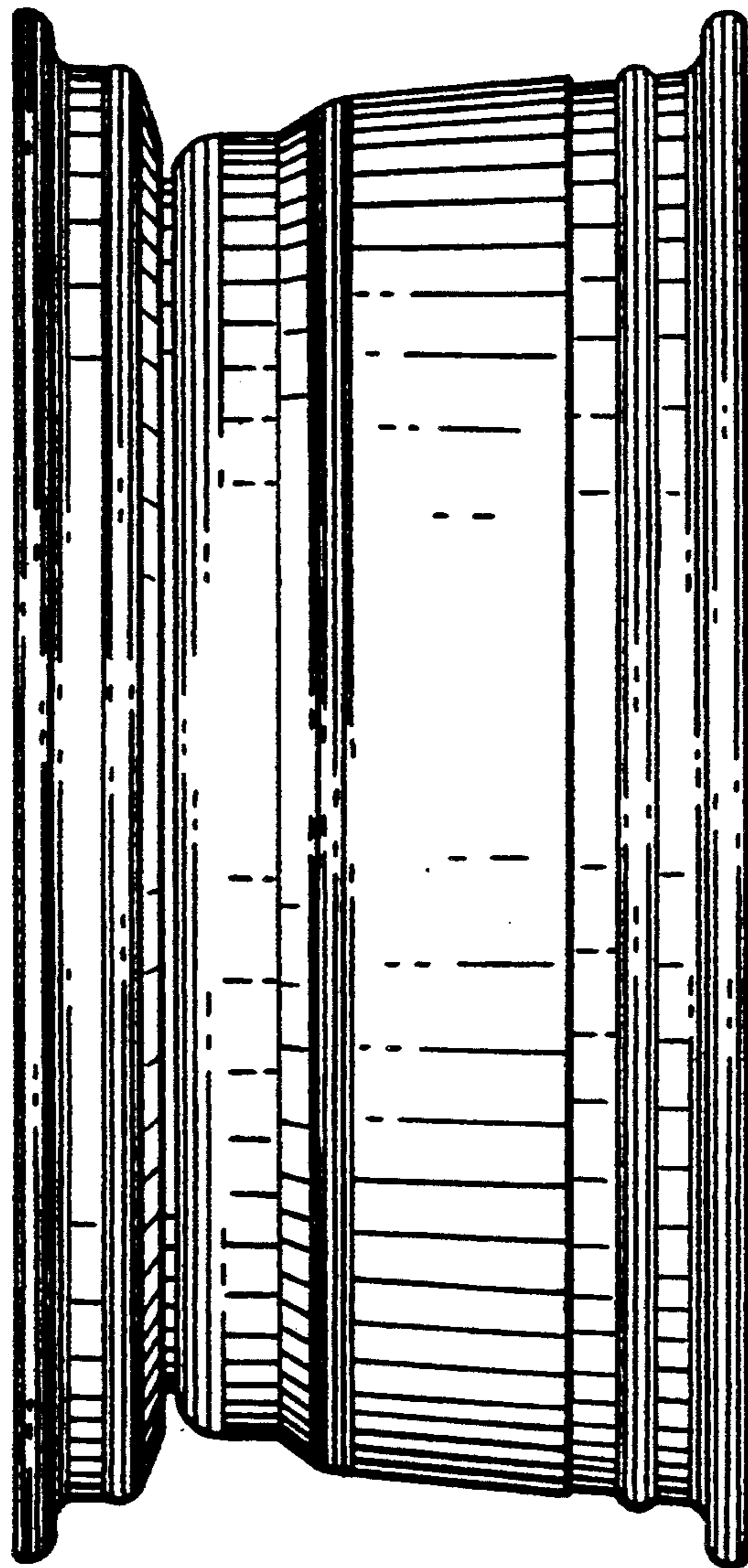

FIG. 9

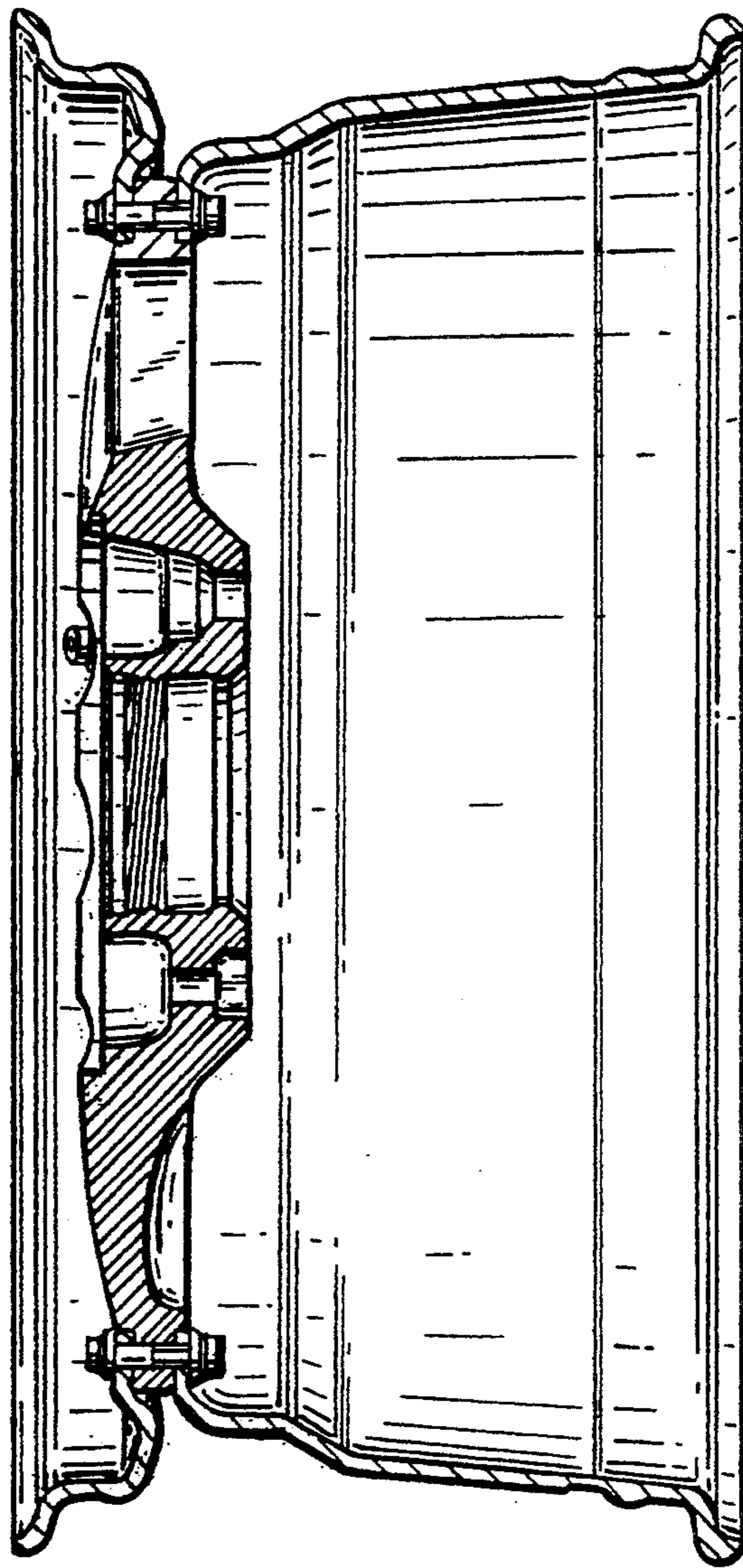

FIG. 10

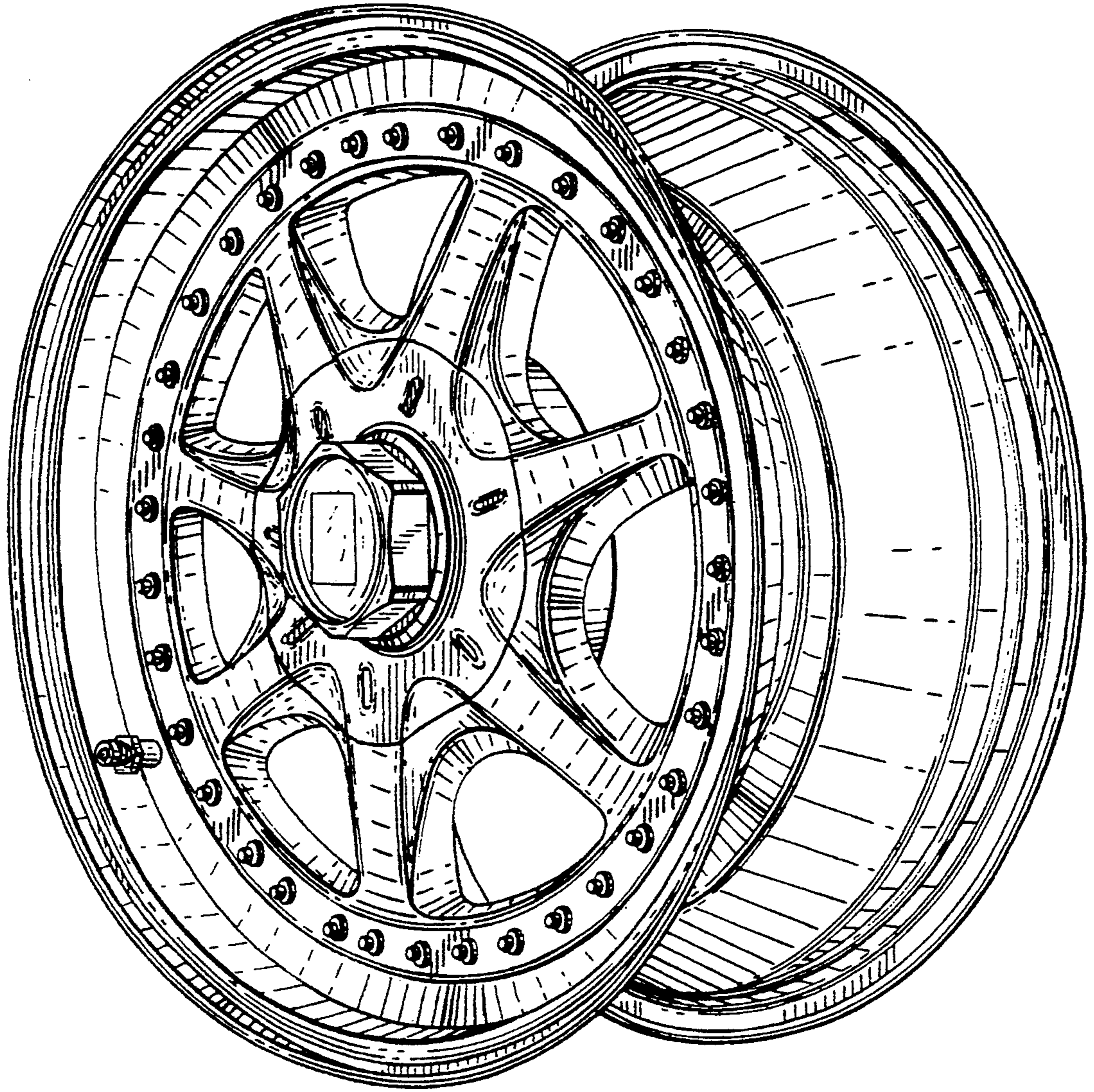

FIG. 11

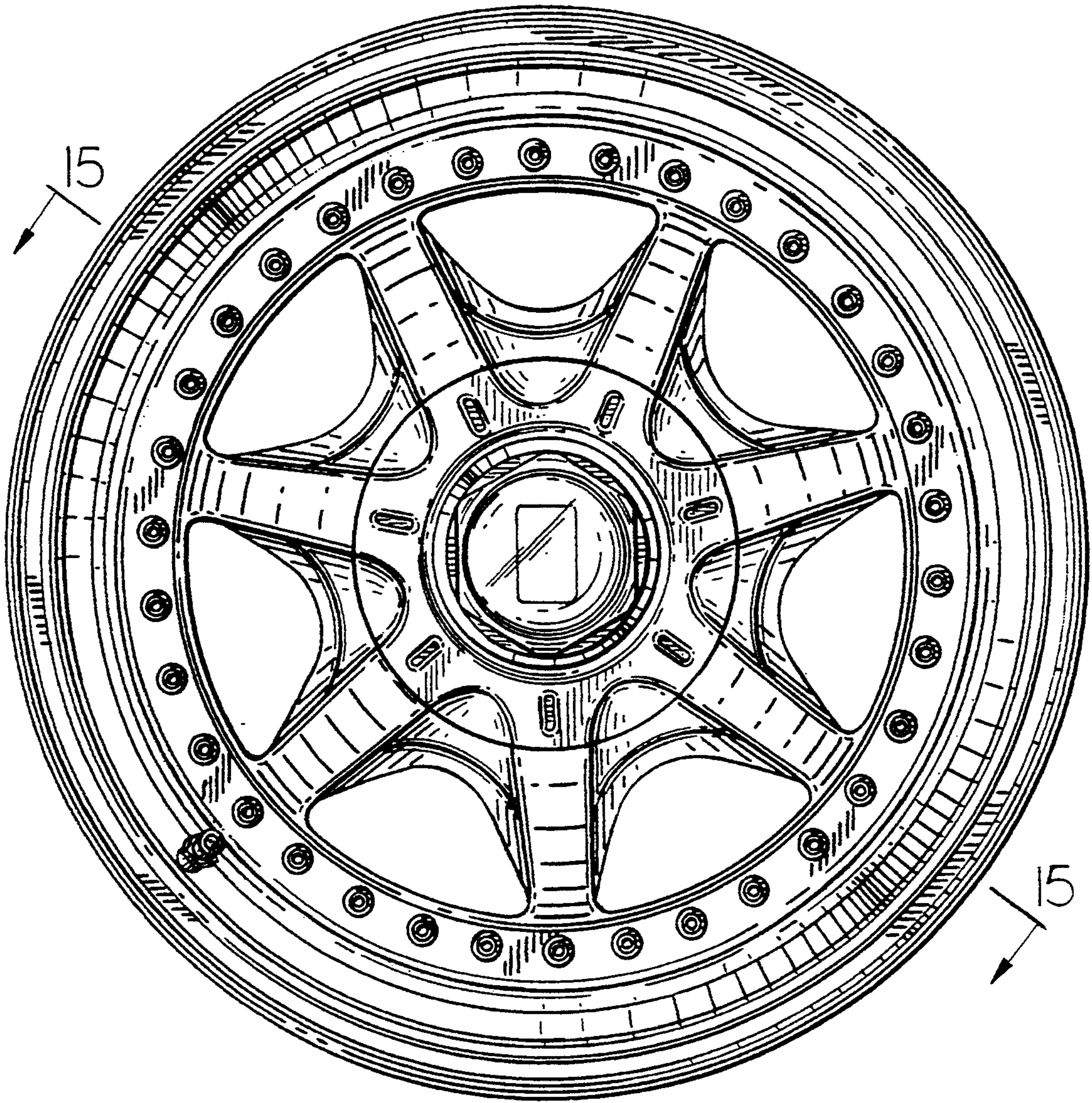

FIG. 12

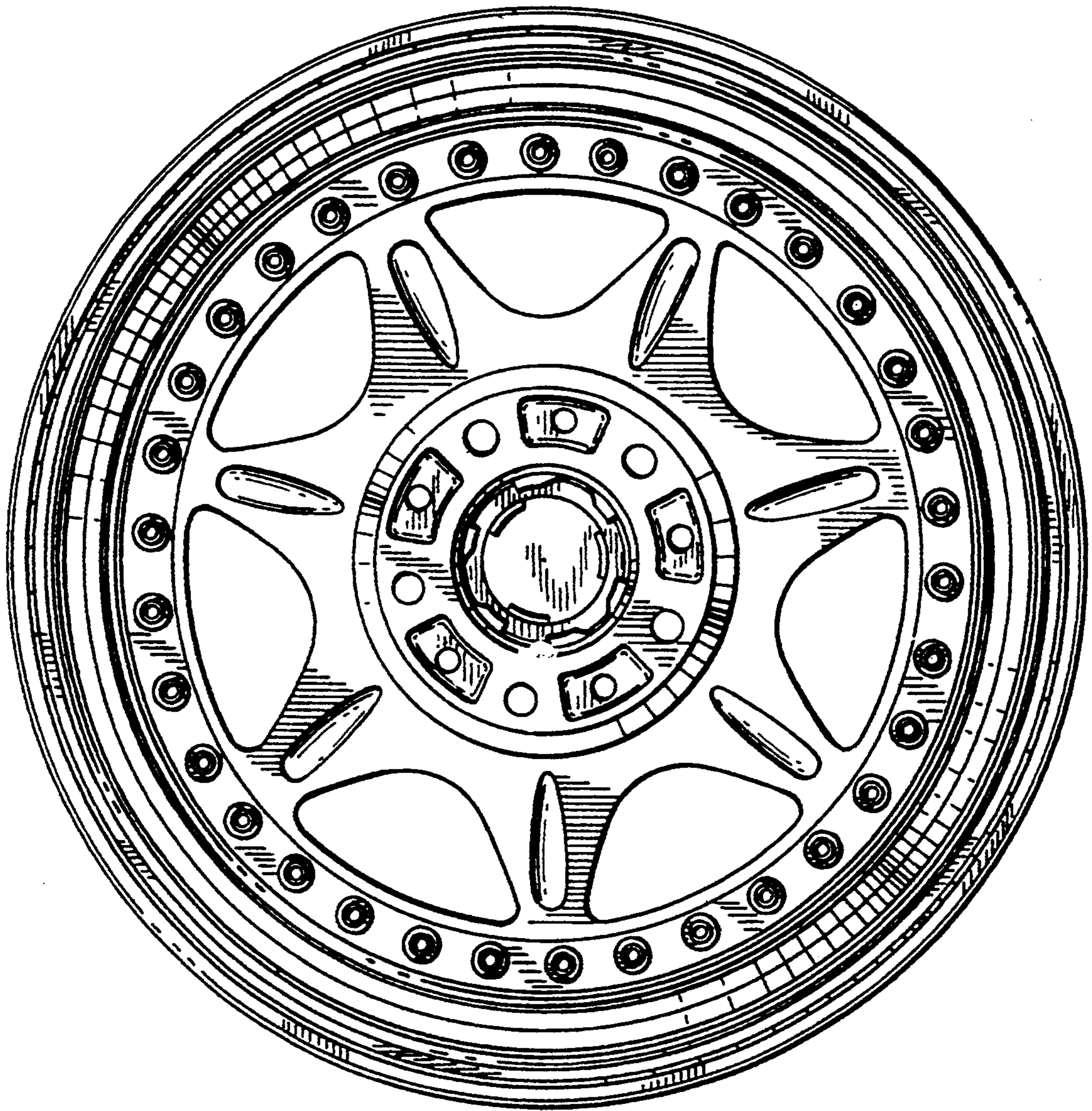

FIG. 13

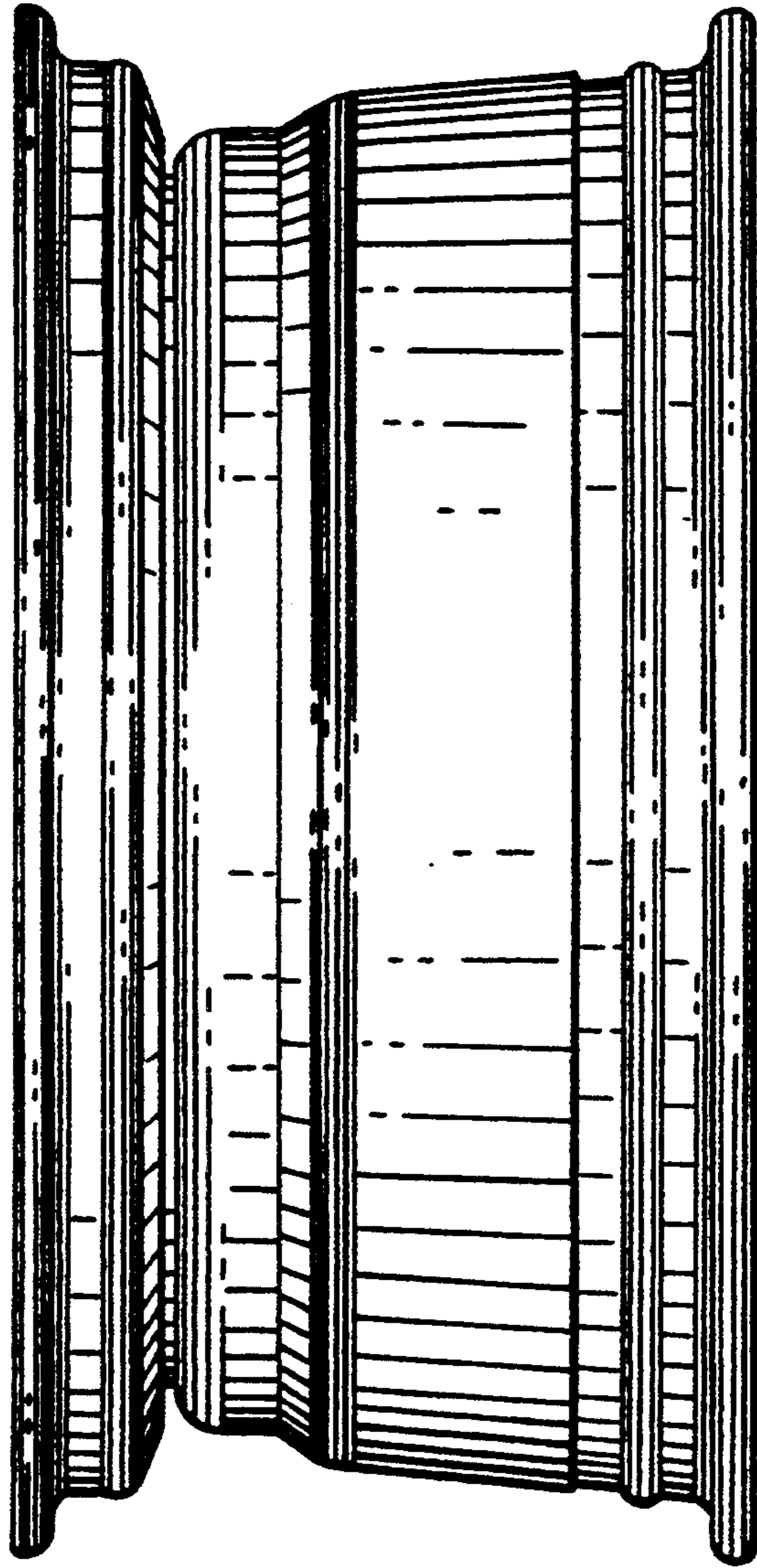

FIG. 14

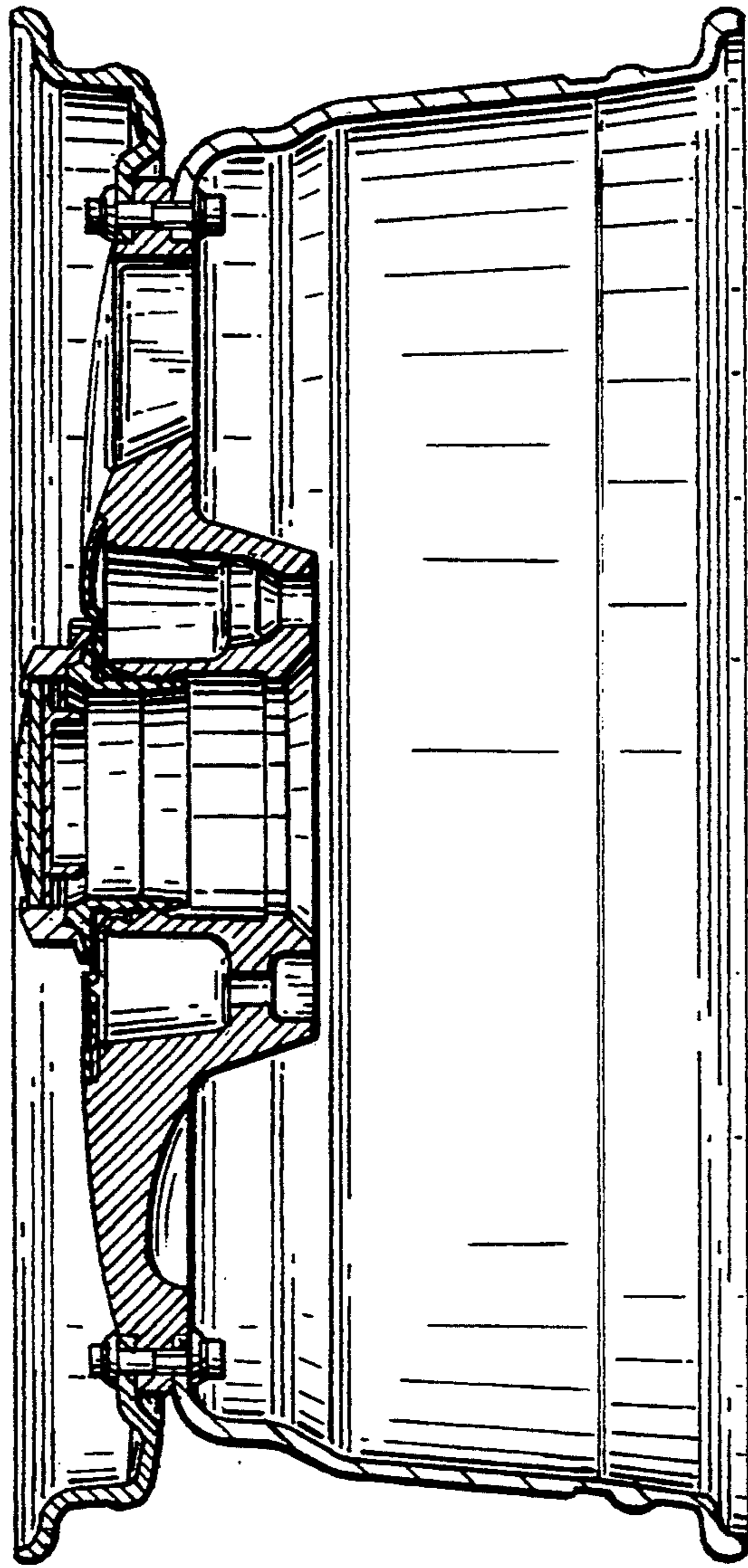

FIG. 15

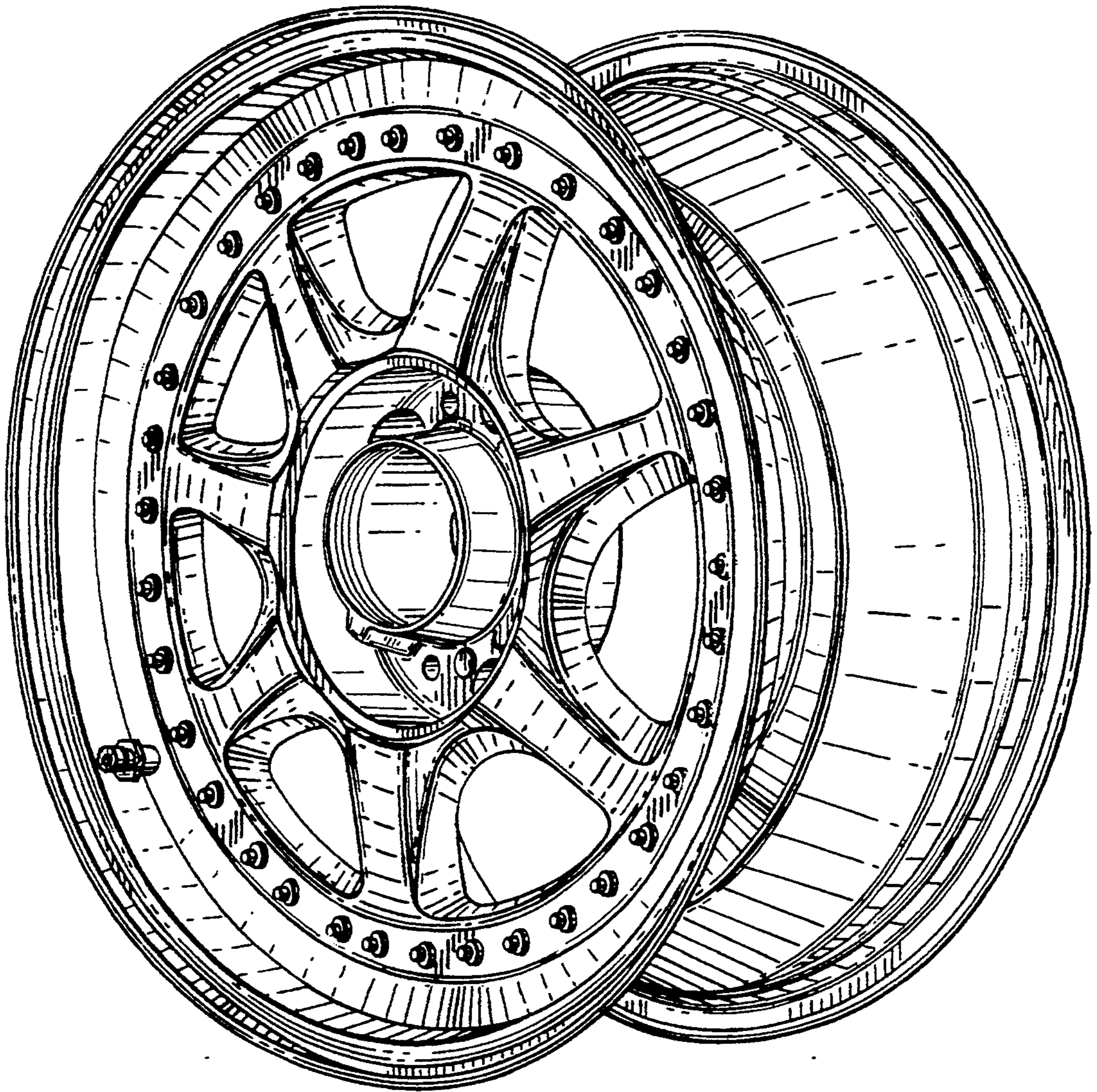

FIG. 16

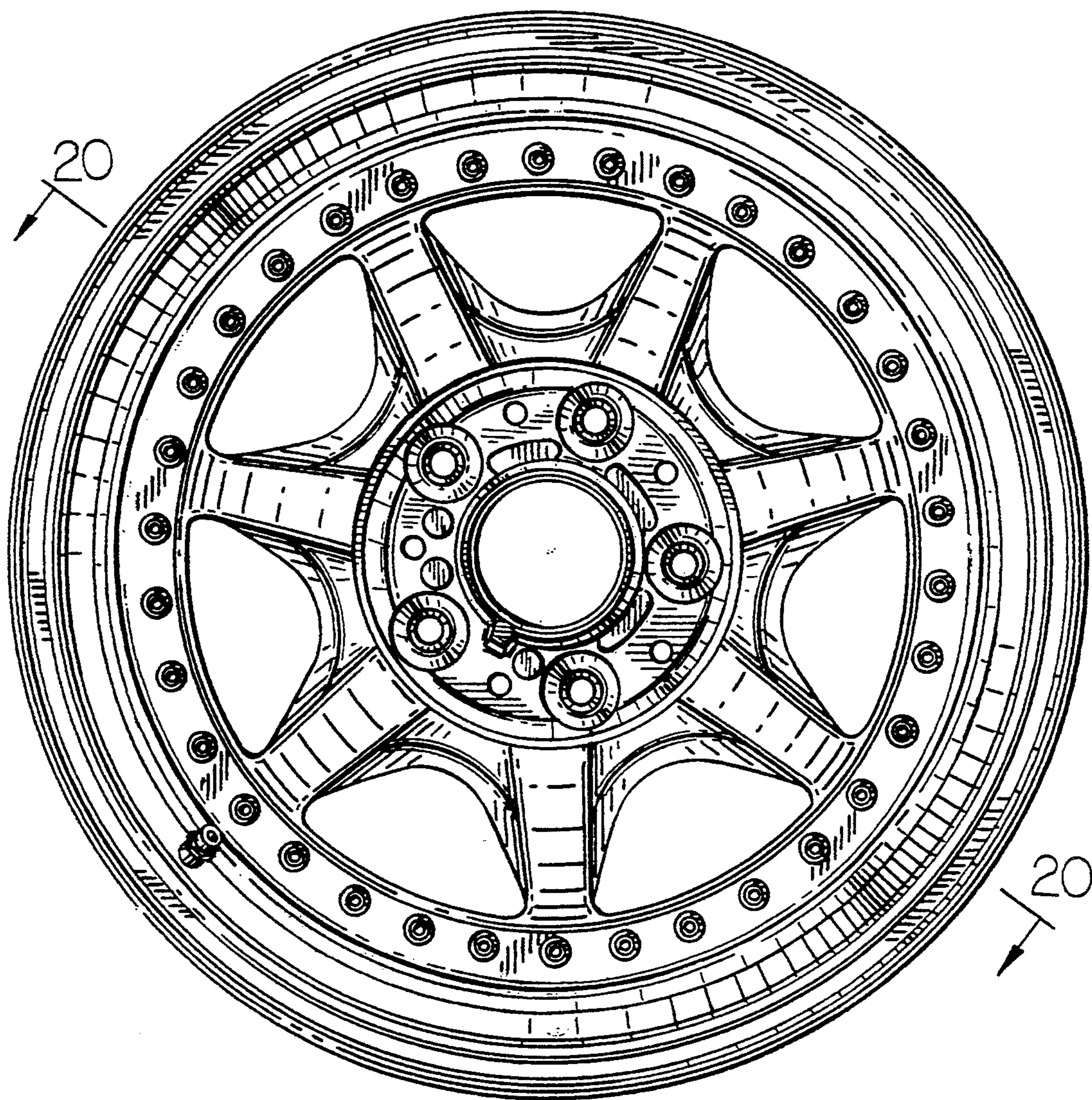

FIG.17

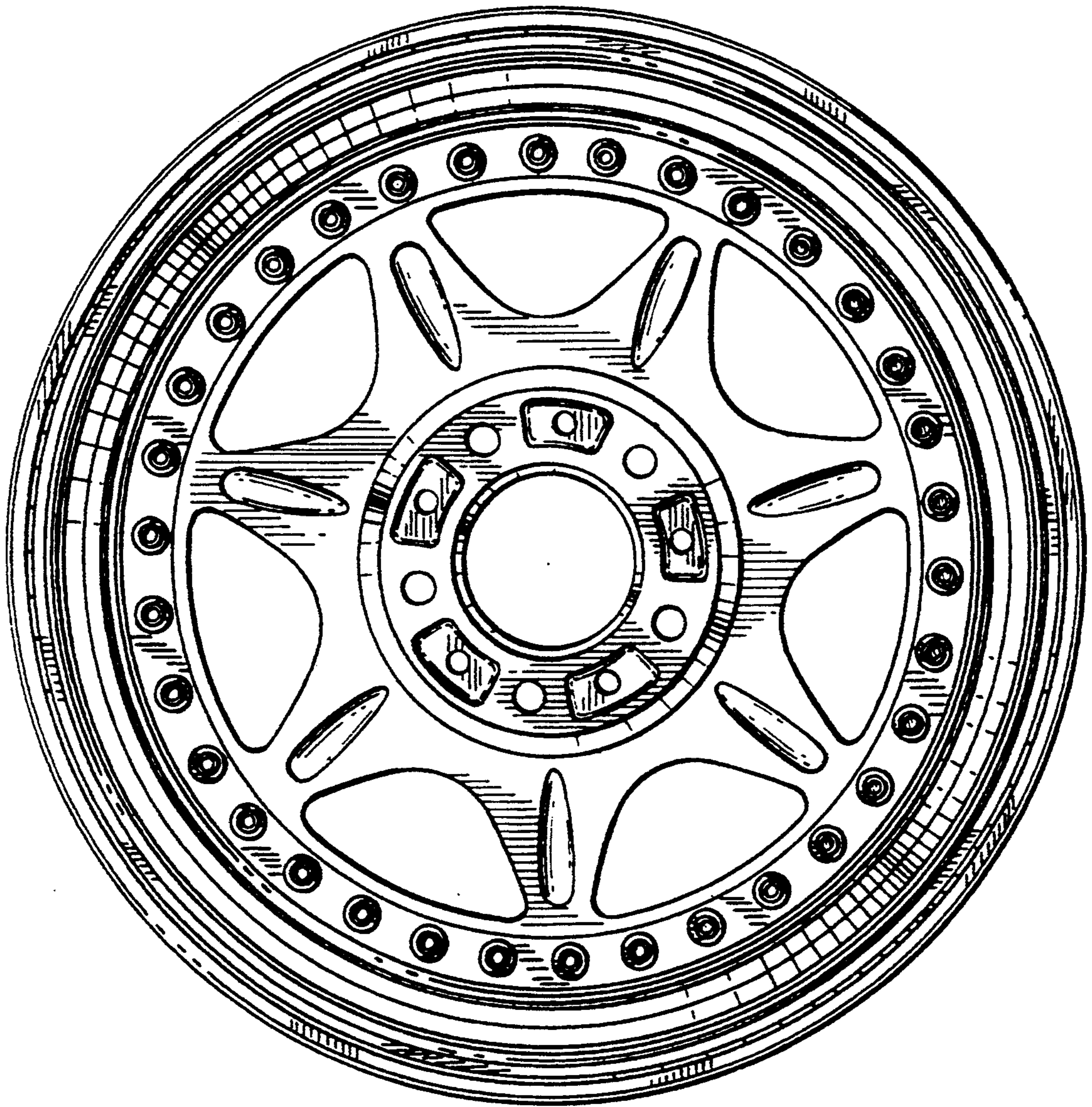

FIG. 18

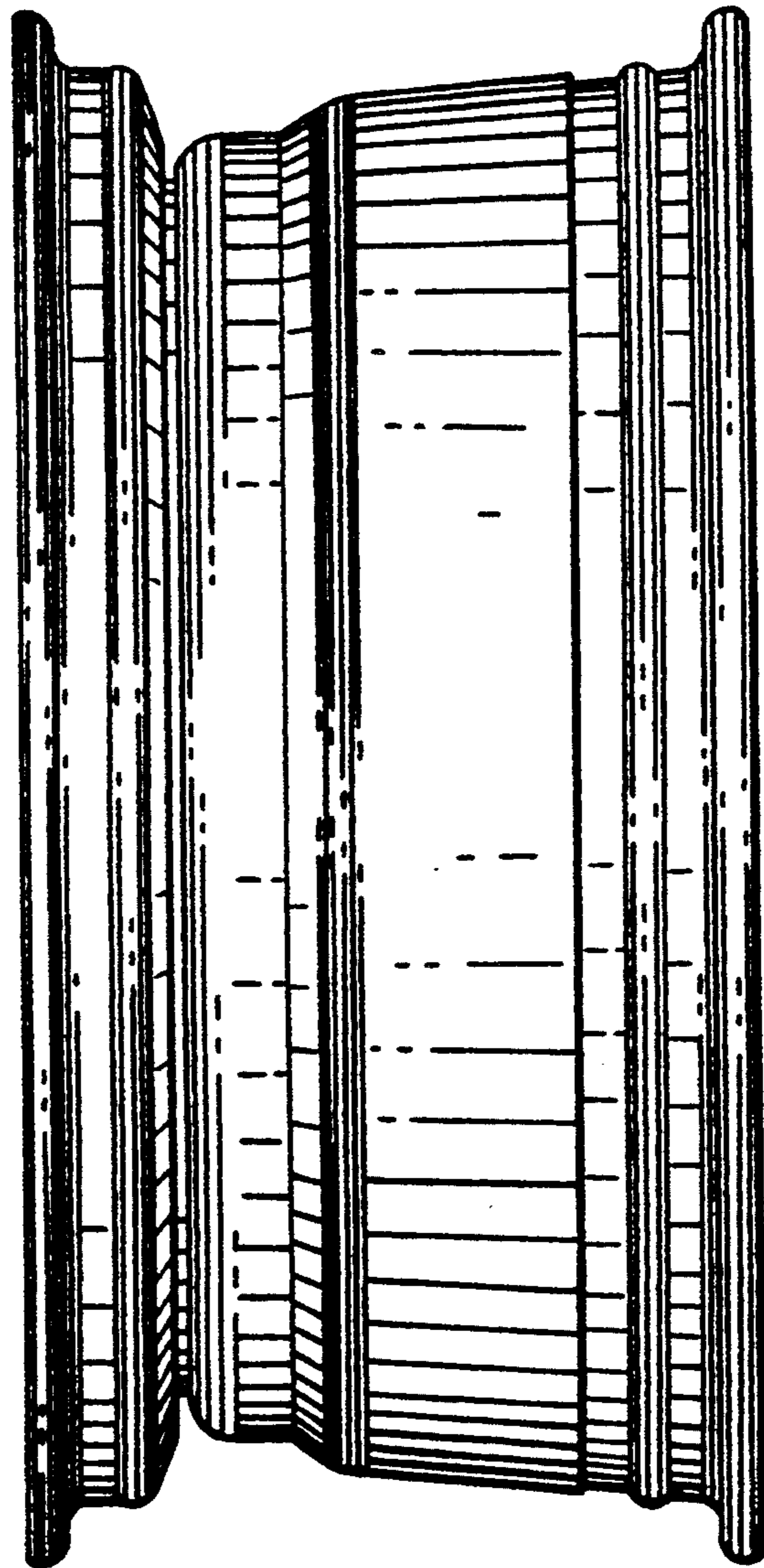

FIG. 19

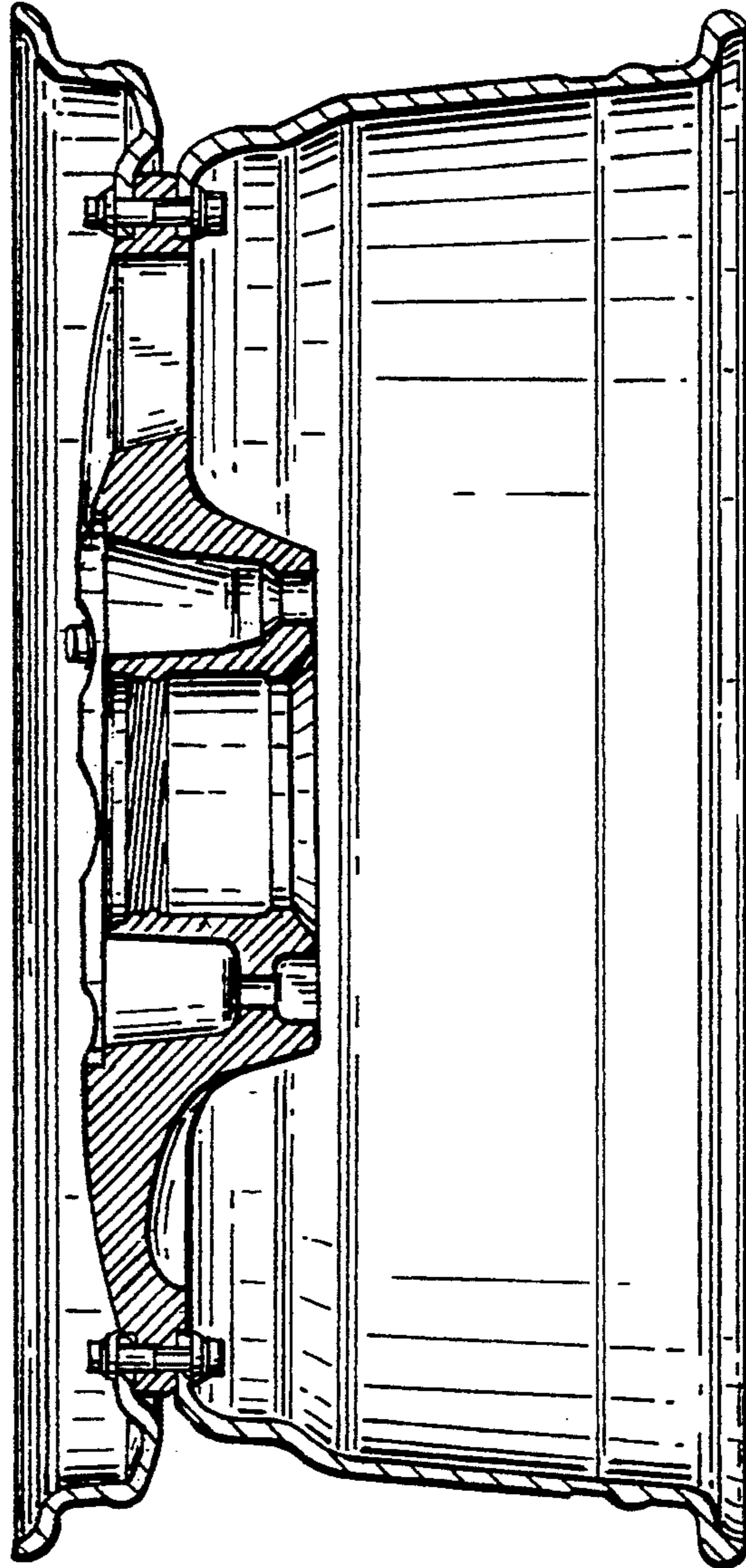

FIG. 20