



US00D352508S

United States Patent [19]

[11] Patent Number: **Des. 352,508**

Noda

[45] Date of Patent: **** Nov. 15, 1994**

[54] **DRILLING MACHINE FOR RAILROAD RAIL**

[56] **References Cited**

[75] Inventor: **Hirotooshi Noda**, Atsugi, Japan

U.S. PATENT DOCUMENTS

4,500,081	2/1985	Carossino	269/226
4,753,556	6/1988	Solko	408/108
4,911,587	3/1990	Stych	408/79

[73] Assignee: **Kabushiki Kaisha Yamazaki Haguruma Seisakusho**, Atsugi, Japan

Primary Examiner—Alan P. Douglas
Assistant Examiner—Antoine D. Davis
Attorney, Agent, or Firm—Keck, Mahin & Cate

[**] Term: **14 Years**

[57] CLAIM

The ornamental design for a drilling machine for railroad rail, as shown and described.

[21] Appl. No.: **10,672**

DESCRIPTION

[22] Filed: **Jul. 15, 1993**
 [52] U.S. Cl. **D15/132**
 [58] Field of Search D8/61; 269/94, 226, 269/238, 257; 408/78, 79, 87, 92, 97, 98, 99, 100, 103, 108, 110, 113, 114, 125, 172, 233, 713; D15/132, 199

FIG. 1 is a left side perspective view of a drilling machine for railroad rail showing my design;
 FIG. 2 is a right side perspective view thereof;
 FIG. 3 is a right side elevational view thereof;
 FIG. 4 is a left side elevational view thereof;
 FIG. 5 is a front elevational view thereof;
 FIG. 6 is a rear elevational view thereof; and,
 FIG. 7 is a top plan view thereof.

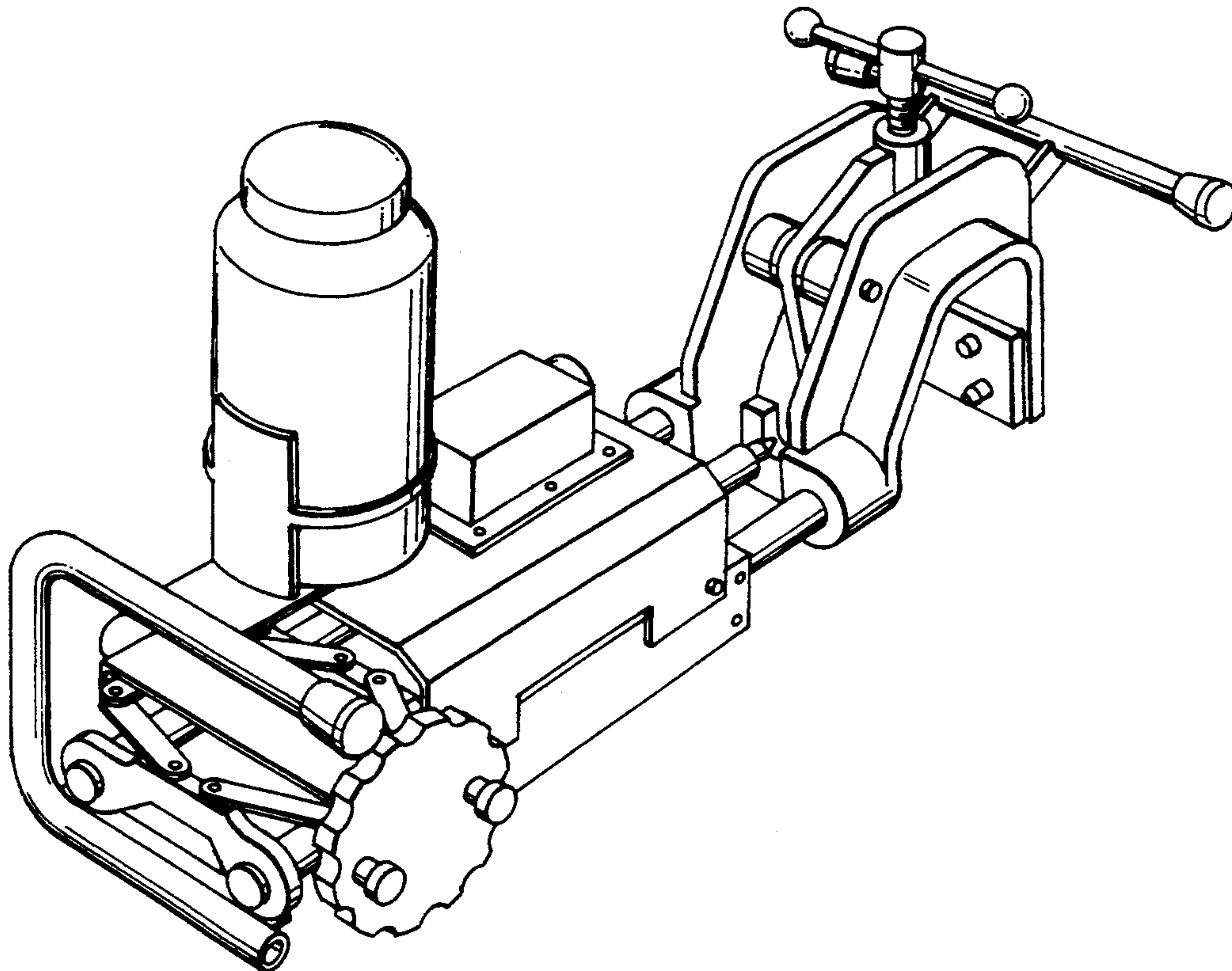

FIG. 1

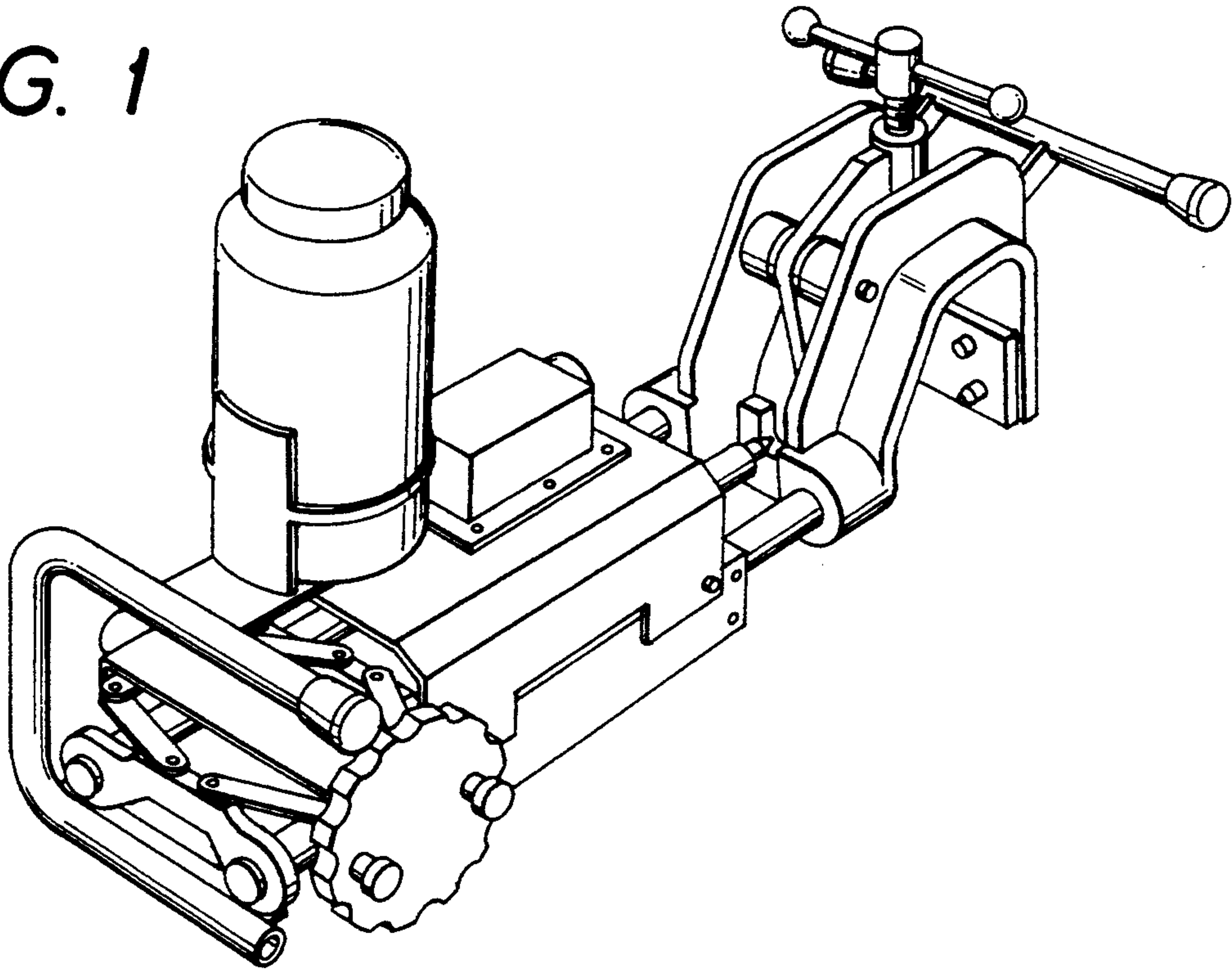

FIG. 2

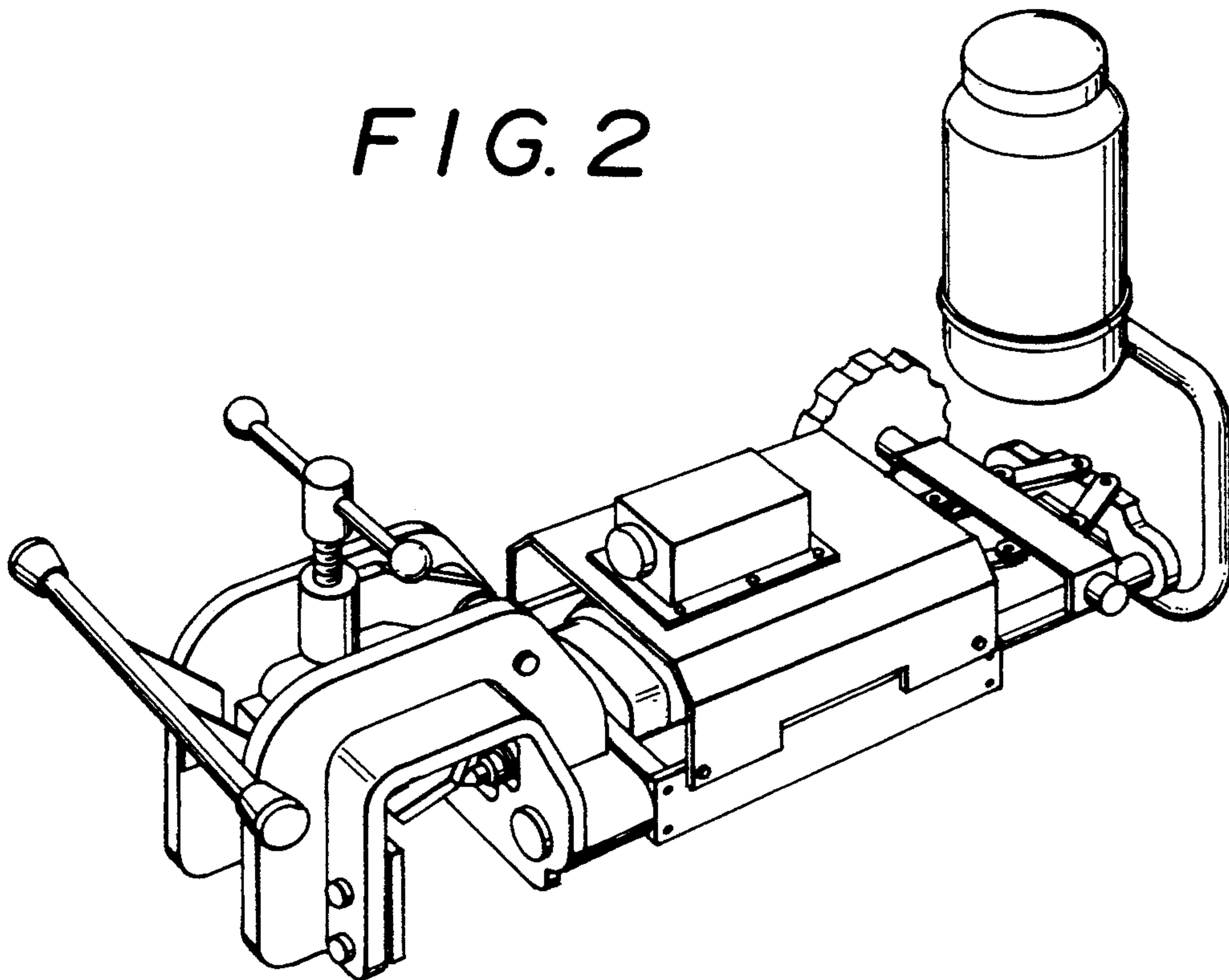

FIG. 3

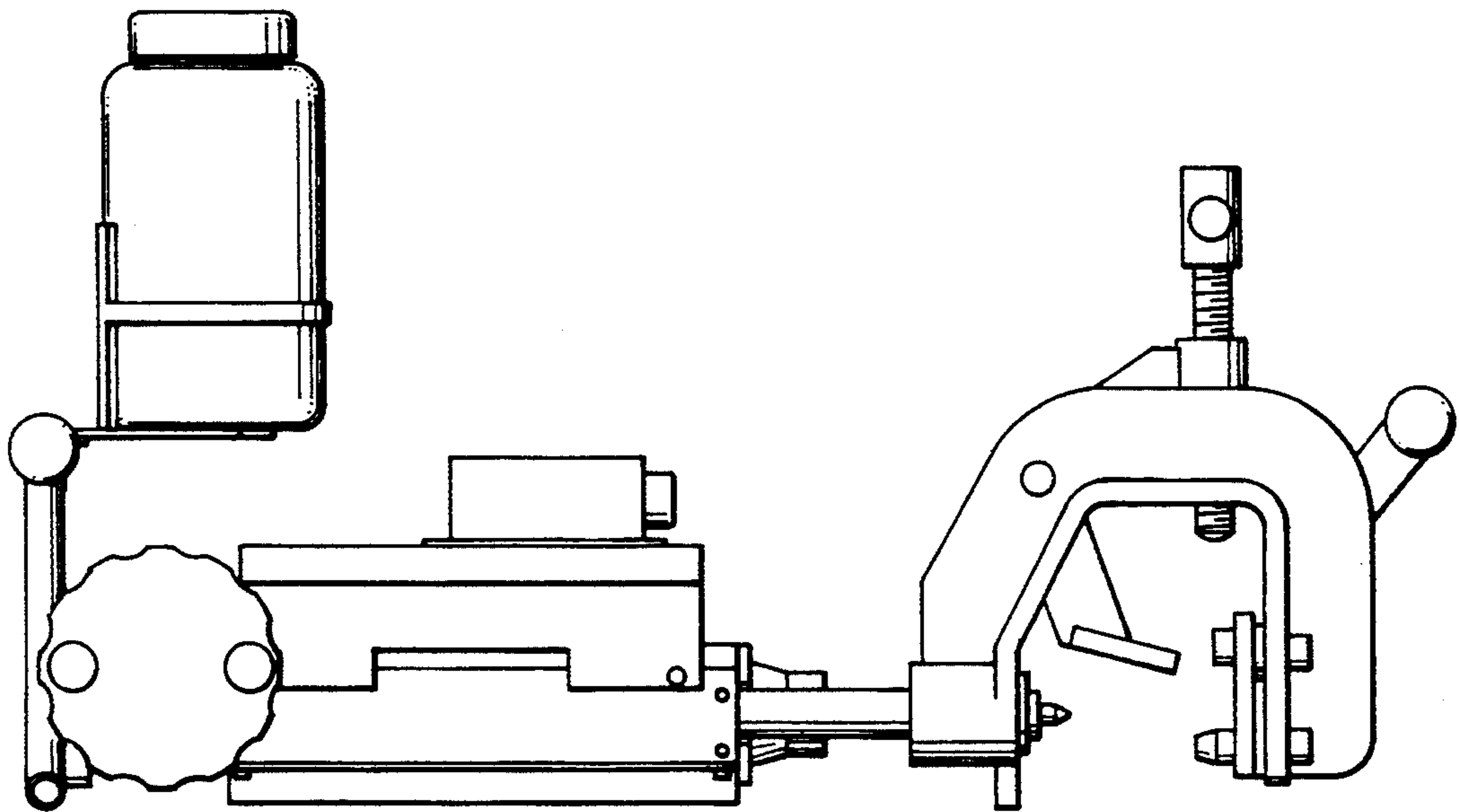

FIG. 4

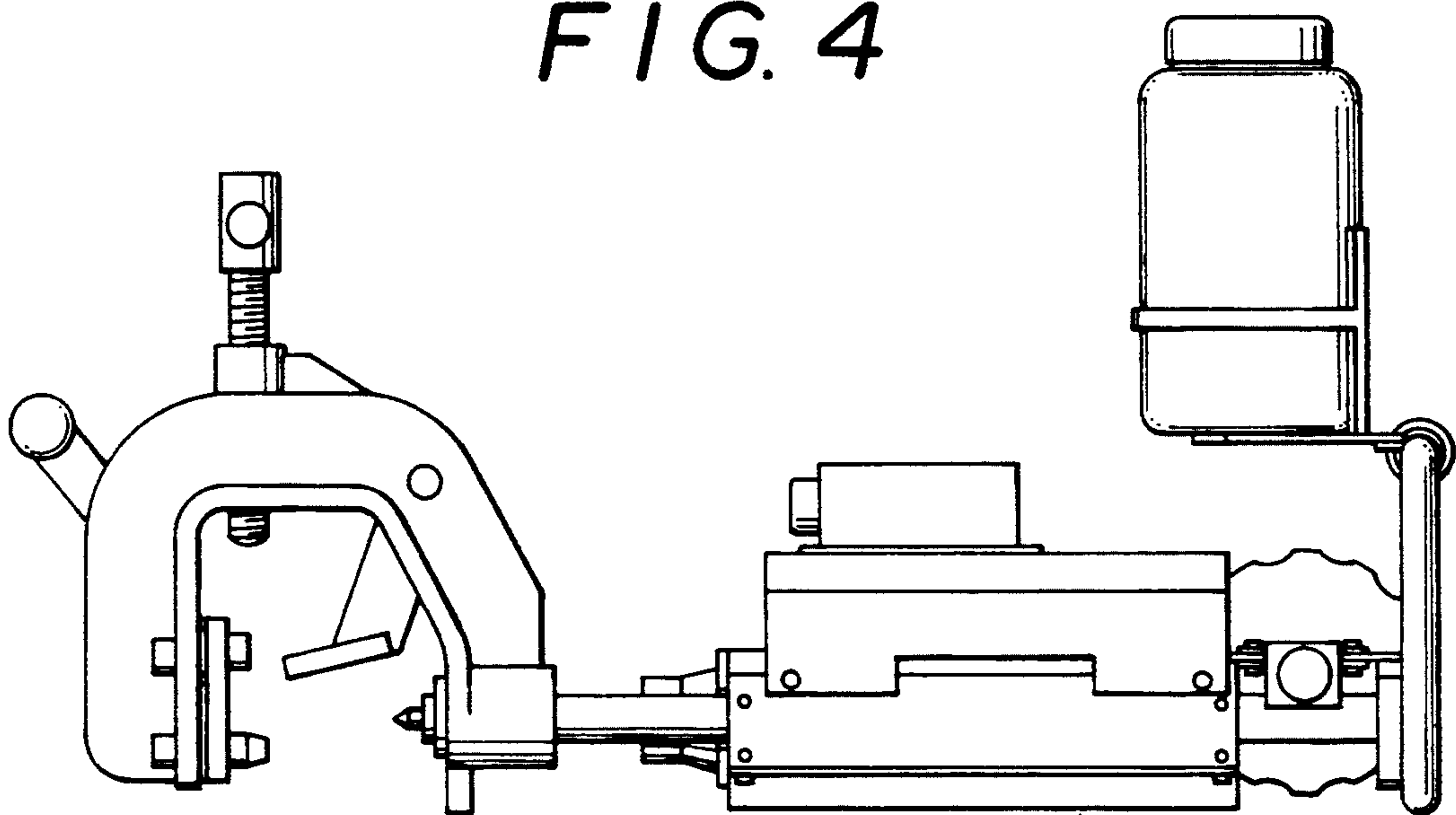

FIG. 5

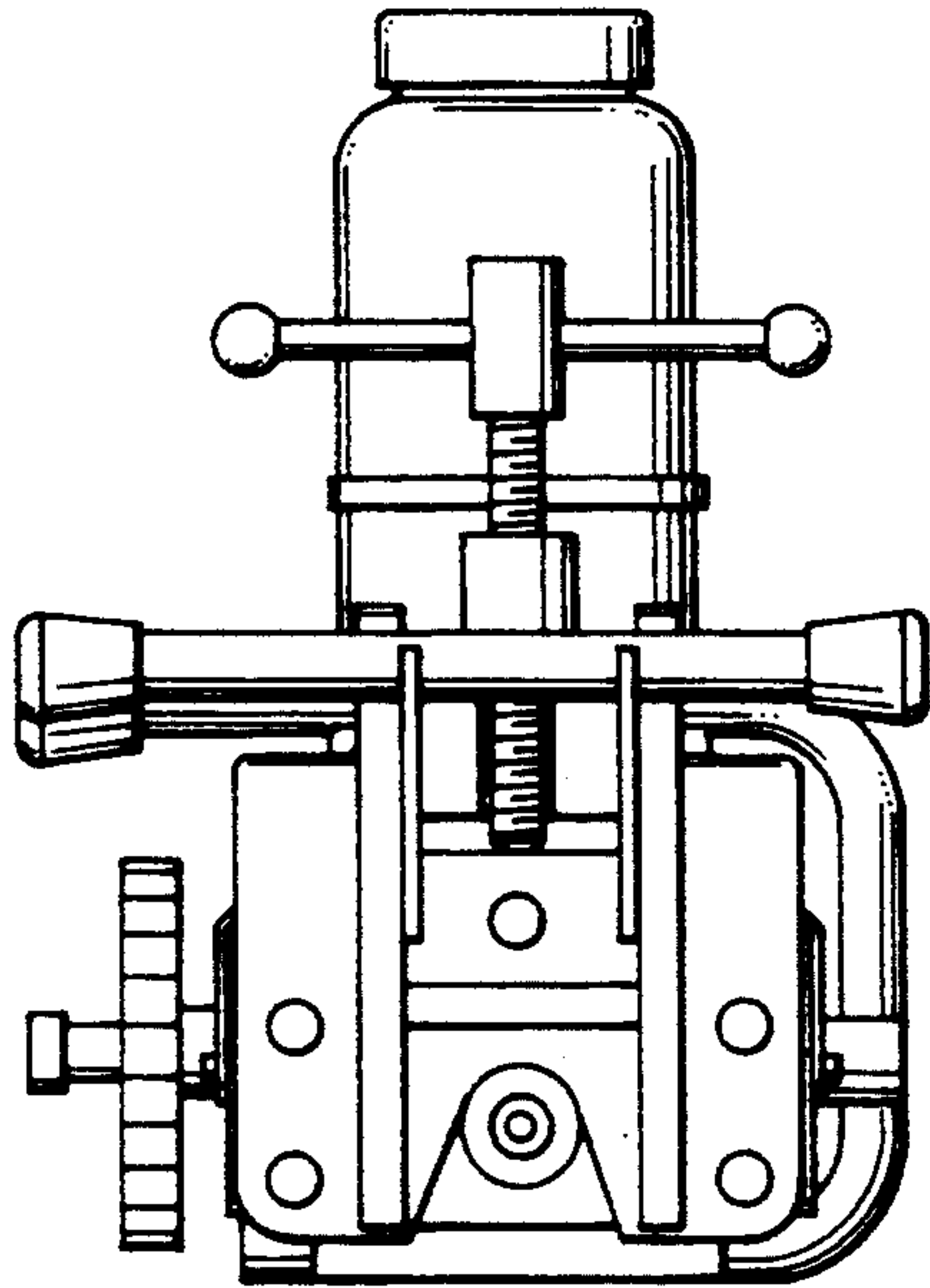

FIG. 6

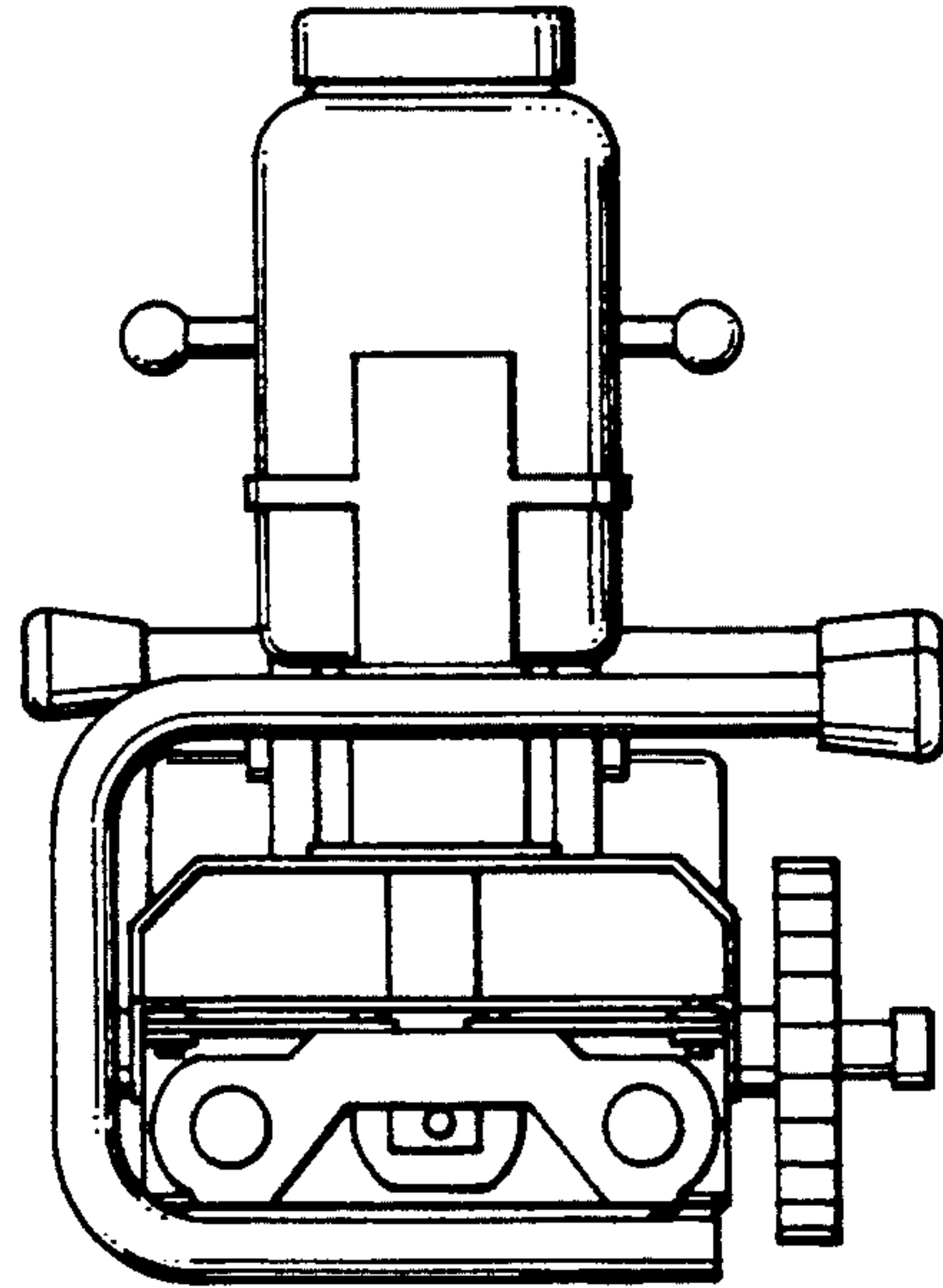

FIG. 7

