



US00D352494S

United States Patent [19]

[11] Patent Number: Des. 352,494

Hubbach et al.

[45] Date of Patent: ** Nov. 15, 1994

[54] VEHICLE TOP

[75] Inventors: Robert N. Hubbach, Clarkston; Thomas C. Gale, Rochester; Ernest J. Barry, Clarkston; K. Neil Walling, Leonard, all of Mich.

[73] Assignee: Chrysler Corporation, Highland Park, Mich.

[**] Term: 14 Years

[21] Appl. No.: 11,479

[22] Filed: Aug. 5, 1993

[52] U.S. Cl. D12/401

[58] Field of Search 296/210, 103; D12/156

[56] References Cited

U.S. PATENT DOCUMENTS

- D. 223,151 3/1972 Stroud D12/156
- D. 329,212 9/1992 Murkett et al. D12/91
- 3,764,179 10/1973 Burton D12/156

OTHER PUBLICATIONS

Motor Trend, Dec. 1962, Inside Front Cover, Top of XP-755 Chevrolet Corvette Shark Automobile, Center of Page.

Detroit Free Press Magazine, Cover, Dec. 15, 1991, Dodge Viper.

Car and Driver 1992 Road Test Annual, "Dodge Viper RT/10", Fall, 1992, pp. 12-15.

Primary Examiner—James M. Gandy
Attorney, Agent, or Firm—Mark P. Calcaterra

[57] CLAIM

The ornamental design for a vehicle top, as shown and described.

DESCRIPTION

FIG. 1 is a front perspective view of a vehicle top constructed in accordance to the teachings of the present invention, shown attached to a vehicle body, the broken line showing of the vehicle body and tires in the drawing is for illustrative purposes only and forms no part of the claimed design;

FIG. 2 is an enlarged rear perspective view of the vehicle top shown in FIG. 1;

FIG. 3 is an enlarged side view of the vehicle top shown in FIG. 1;

FIG. 4 is an enlarged front view of the vehicle top shown in FIG. 1; and,

FIG. 5 is an enlarged rear view of the vehicle top shown in FIG. 1.

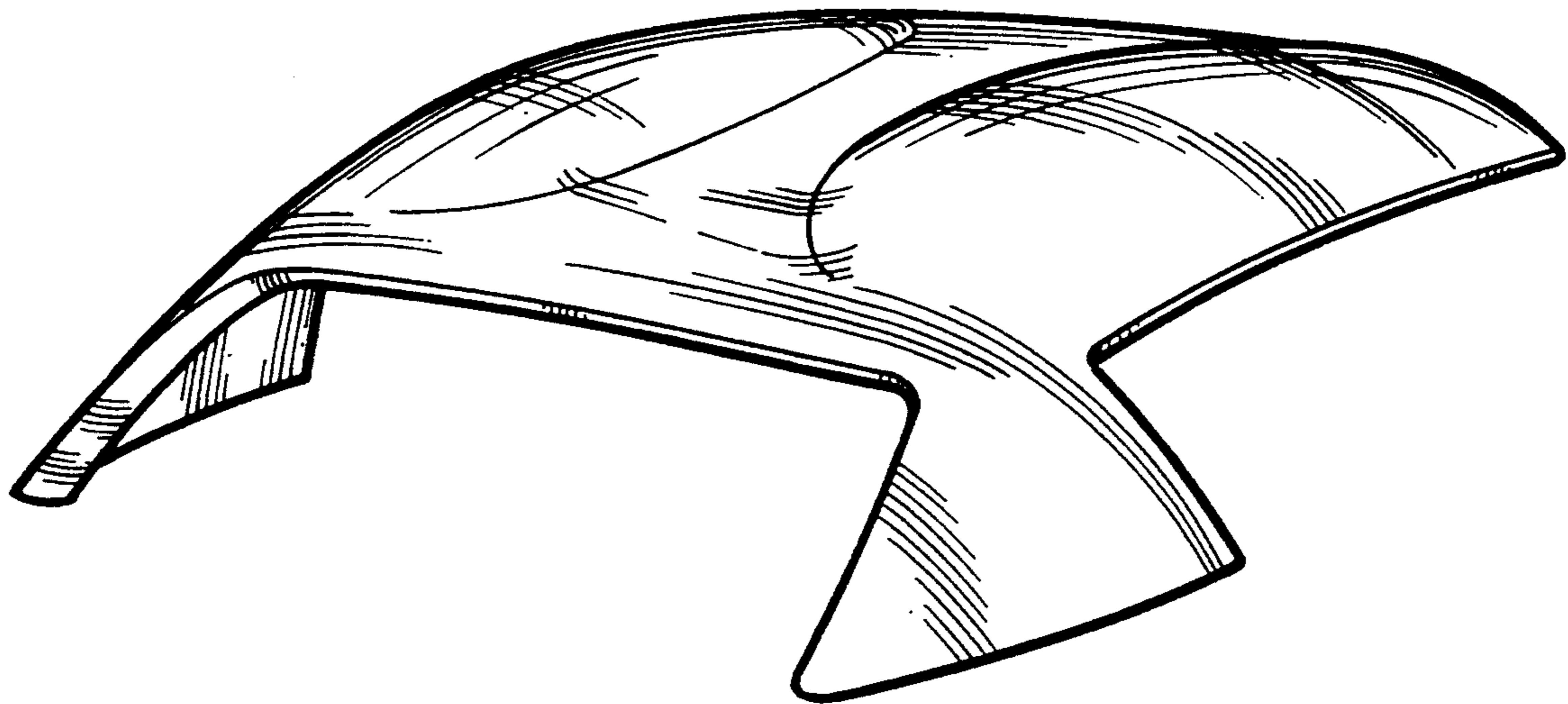

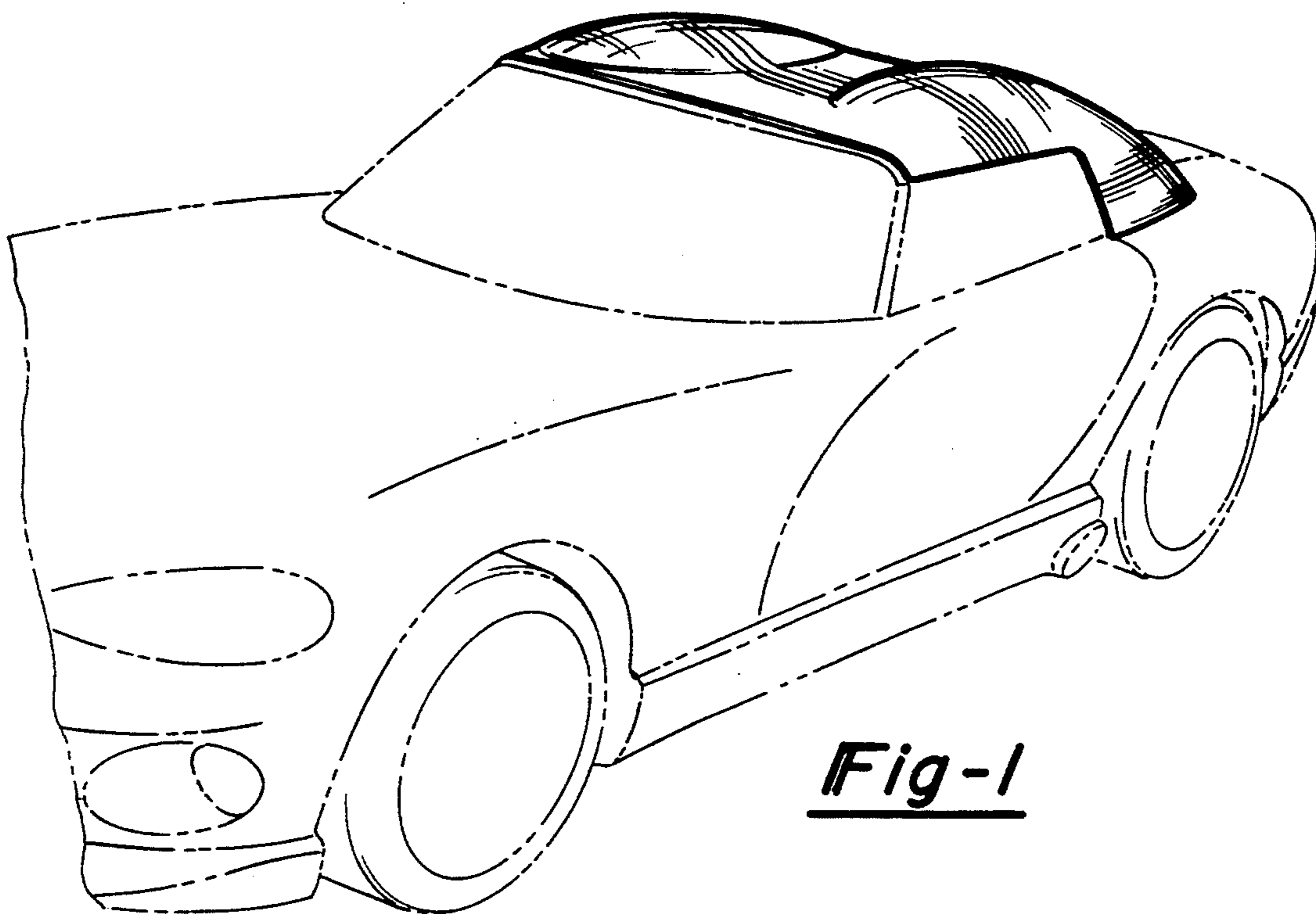

Fig-1

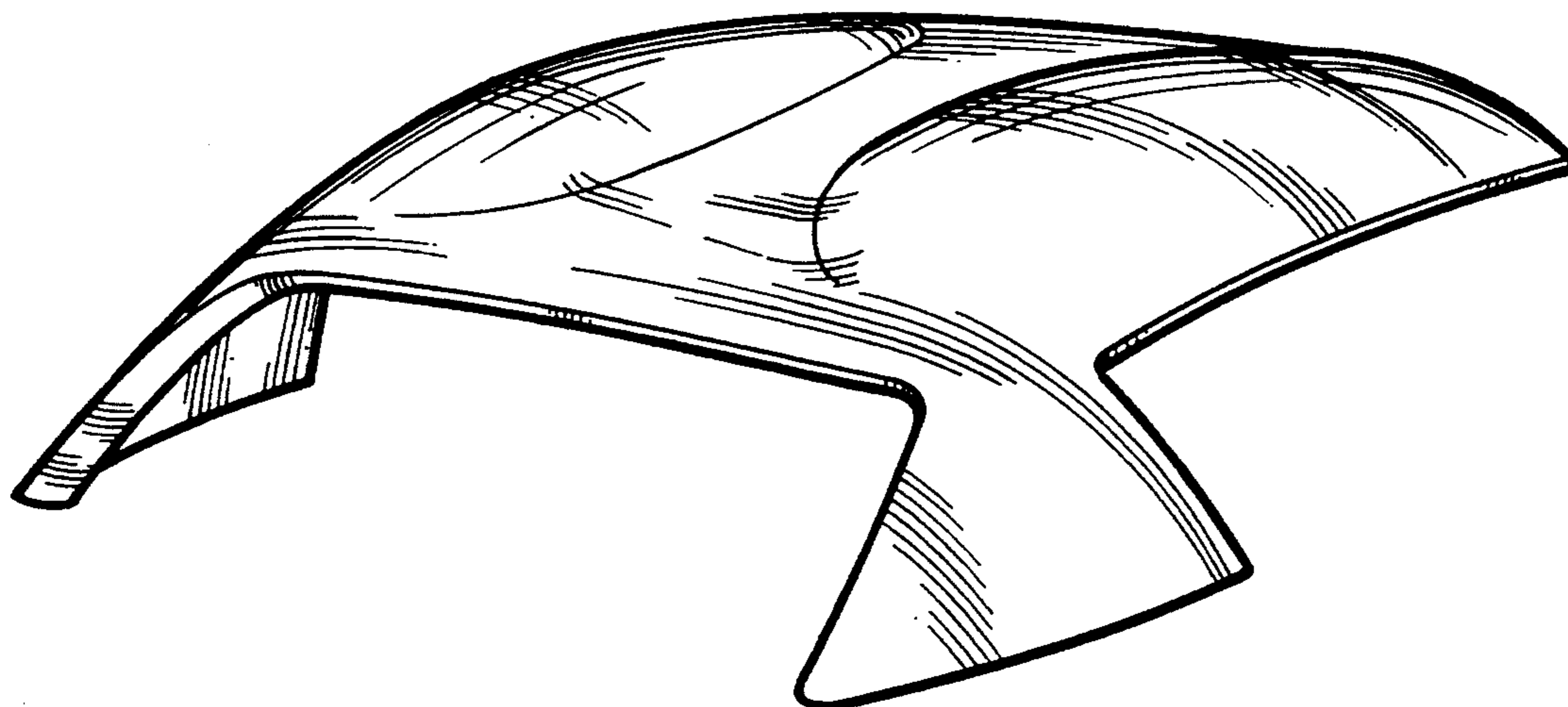

Fig-2

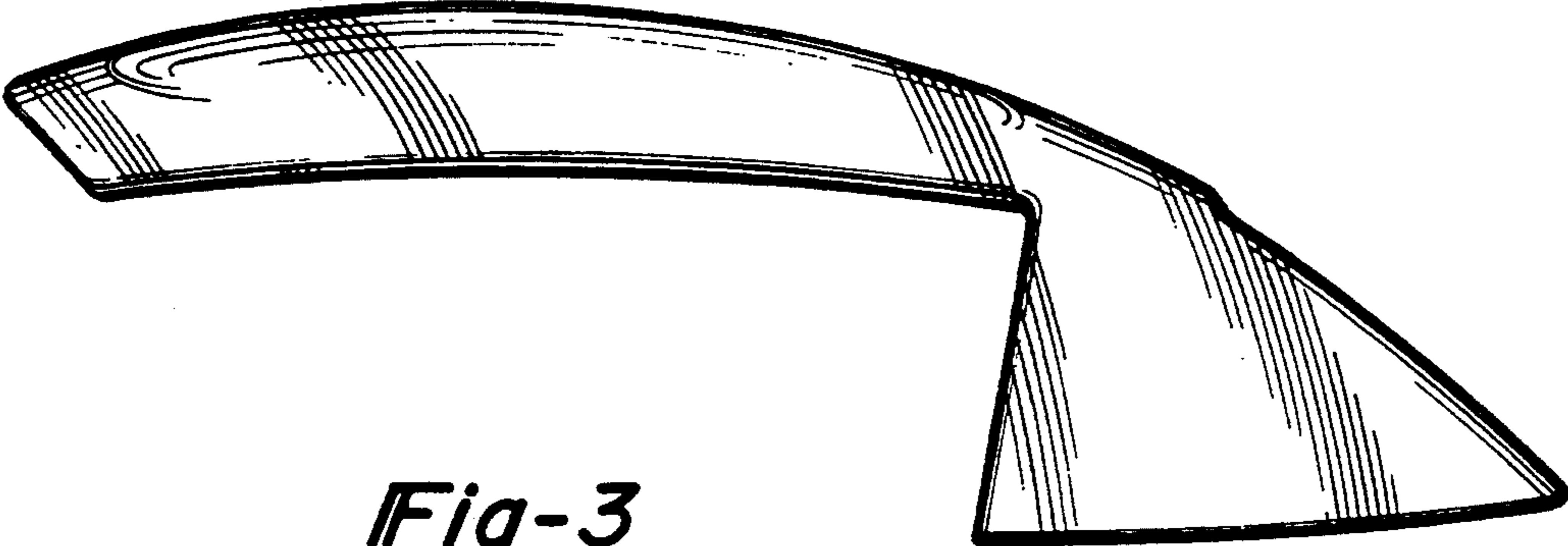

Fig-3

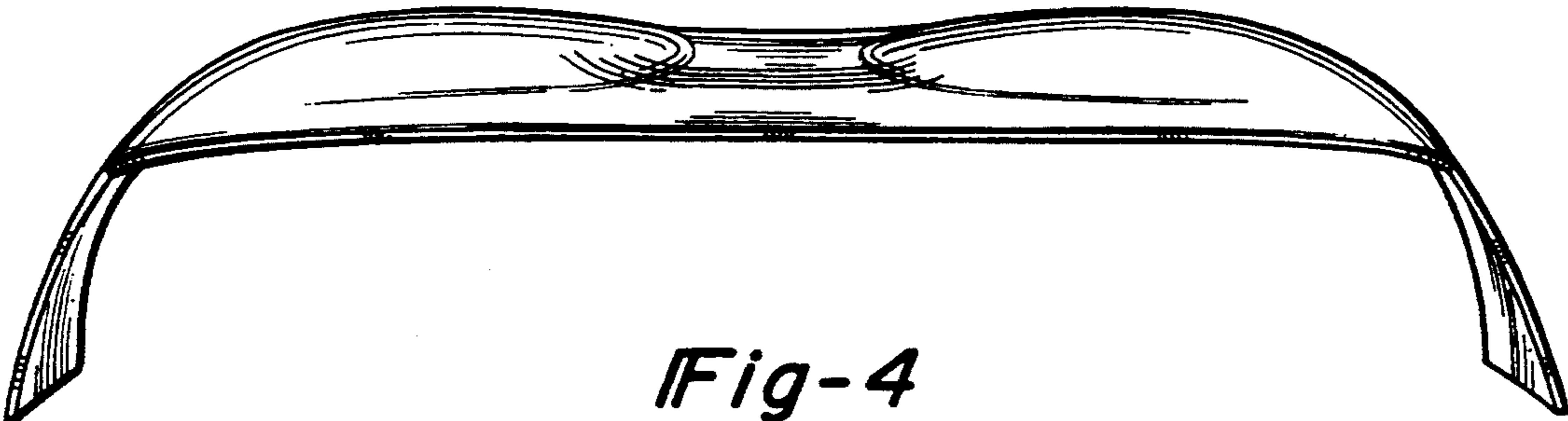

Fig-4

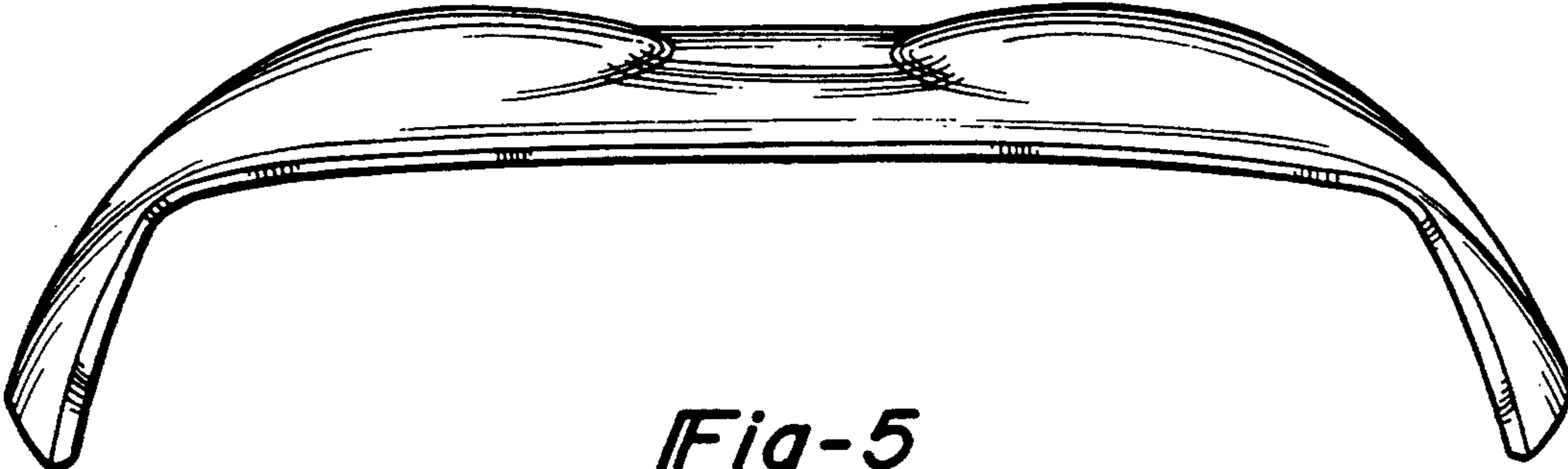

Fig-5