



US00D352493S

United States Patent [19]

[11] Patent Number: **Des. 352,493**

Krojer

[45] Date of Patent: **** Nov. 15, 1994**

[54] AIRPLANE

[75] Inventor: **Hubert Krojer, Bermatingen, Germany**

[73] Assignee: **Dornier Luftfahrt GmbH, Germany**

[**] Term: **14 Years**

[21] Appl. No.: **849,677**

[22] Filed: **Mar. 11, 1992**

[30] Foreign Application Priority Data

Sep. 11, 1991 [DE] Germany M 91 06 545.3

[52] U.S. Cl. **D12/337; D12/341; D12/344**

[58] Field of Search **244/55, 13; D12/319, D12/324, 326, 327, 328, 329, 336, 337, 341, 344**

[56] References Cited

U.S. PATENT DOCUMENTS

- D. 212,512 10/1968 Smith D12/341
- D. 230,717 3/1974 Smith D12/341
- D. 307,885 5/1990 Dupont D12/324

OTHER PUBLICATIONS

Jane's all the World's Aircraft, 1973-1974, p. 44 France Aircraft "Aerospatiale".

Primary Examiner—Kay H. Chin
Attorney, Agent, or Firm—Evenson, McKeown, Edwards & Lenahan

[57] CLAIM

The ornamental design for an airplane, as shown and described.

DESCRIPTION

FIG. 1 is a front view of an airplane embodying my novel design;

FIG. 2 is a left side view thereof;

FIG. 3 is a right side perspective view taken from the front thereof;

FIG. 4 is a bottom view thereof;

FIG. 5 is a rear view thereof; and,

FIG. 6 is a top view thereof.

The broken lines in the drawings are for illustrative purposes only and the plane designation "328" form no part of the claimed design.

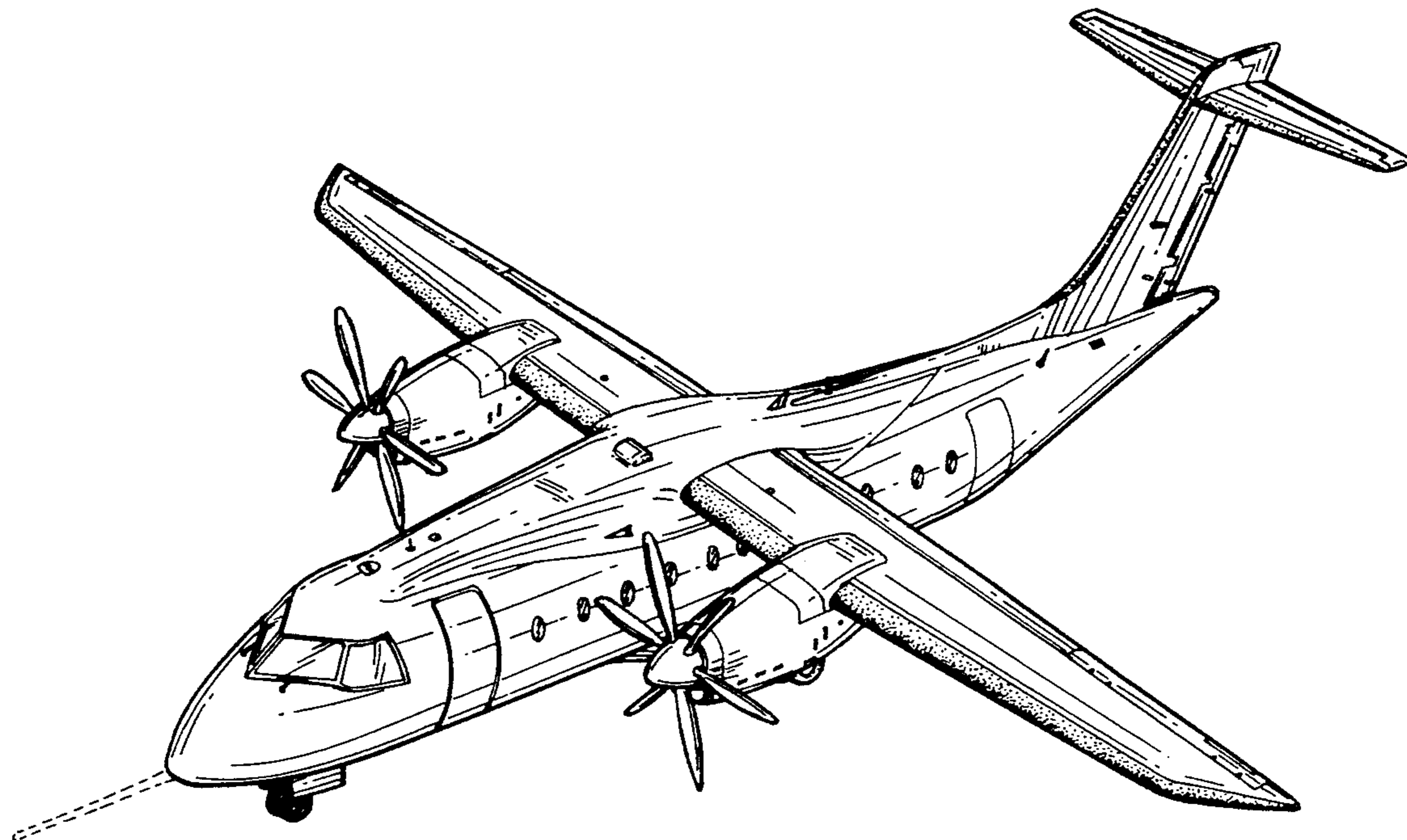

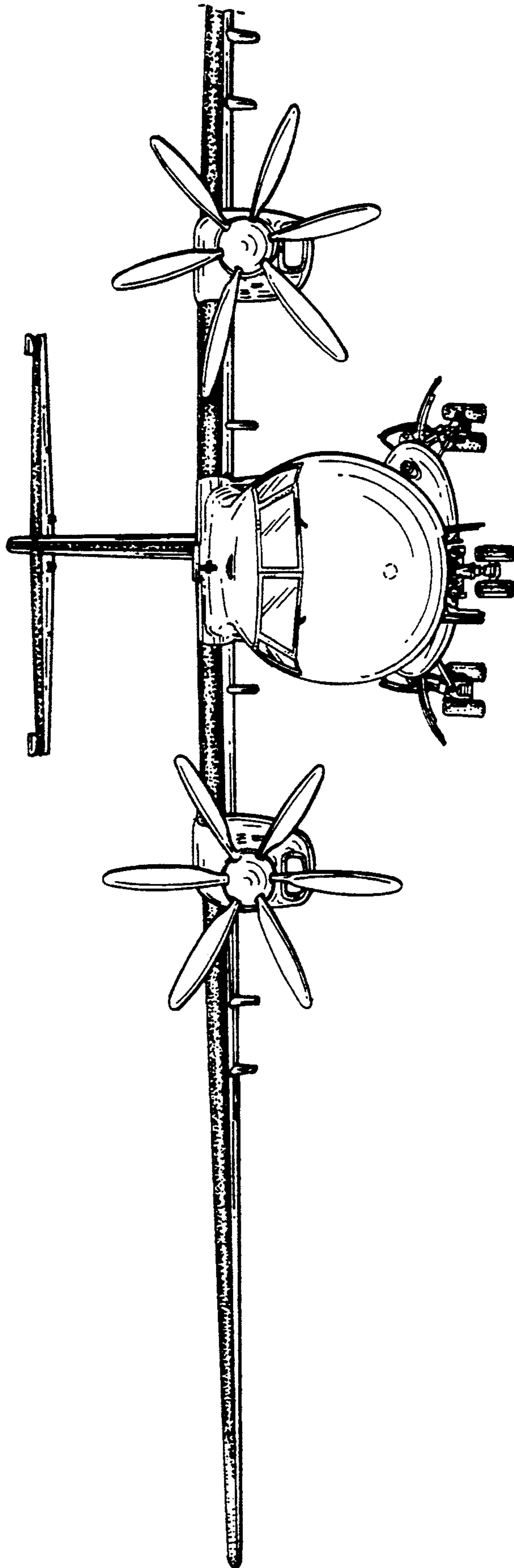

FIG. 1

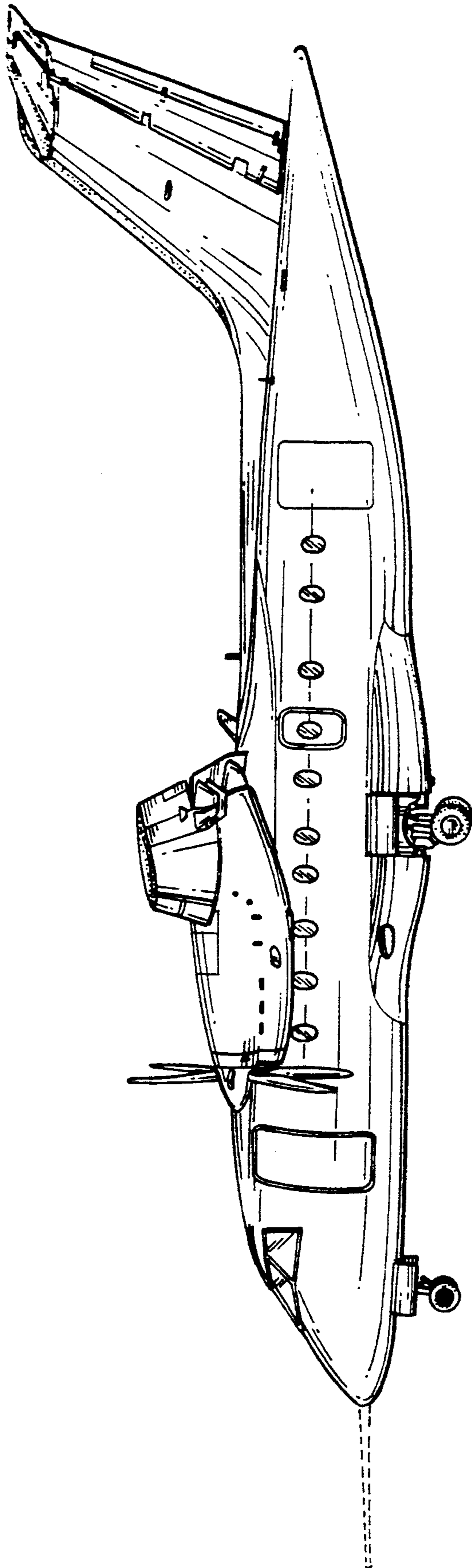

FIG. 2

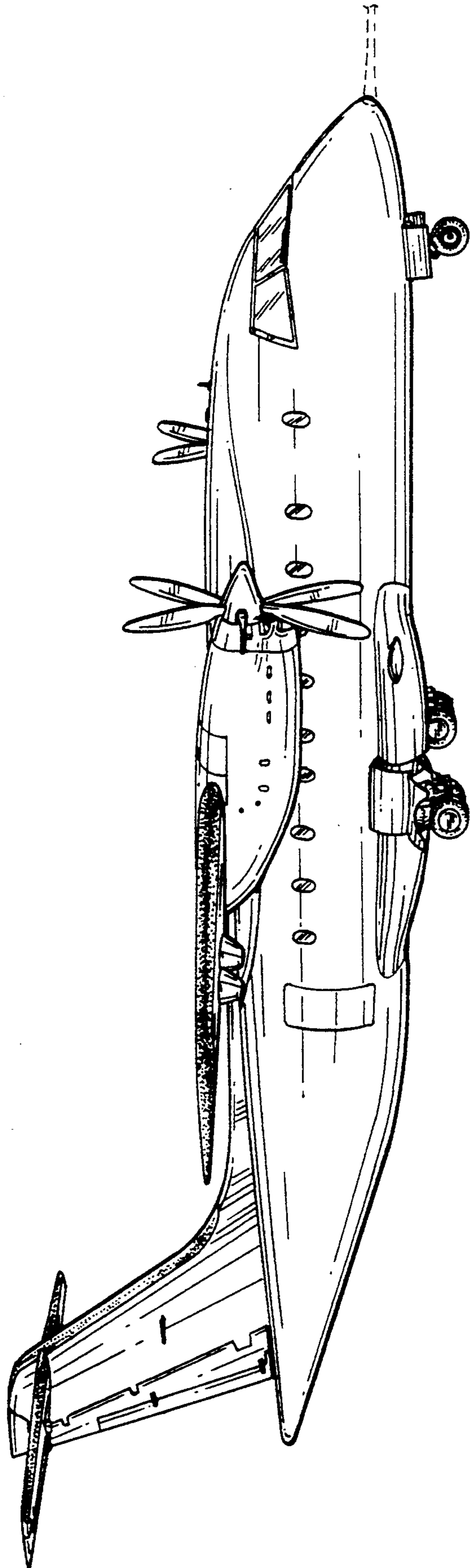

FIG. 3

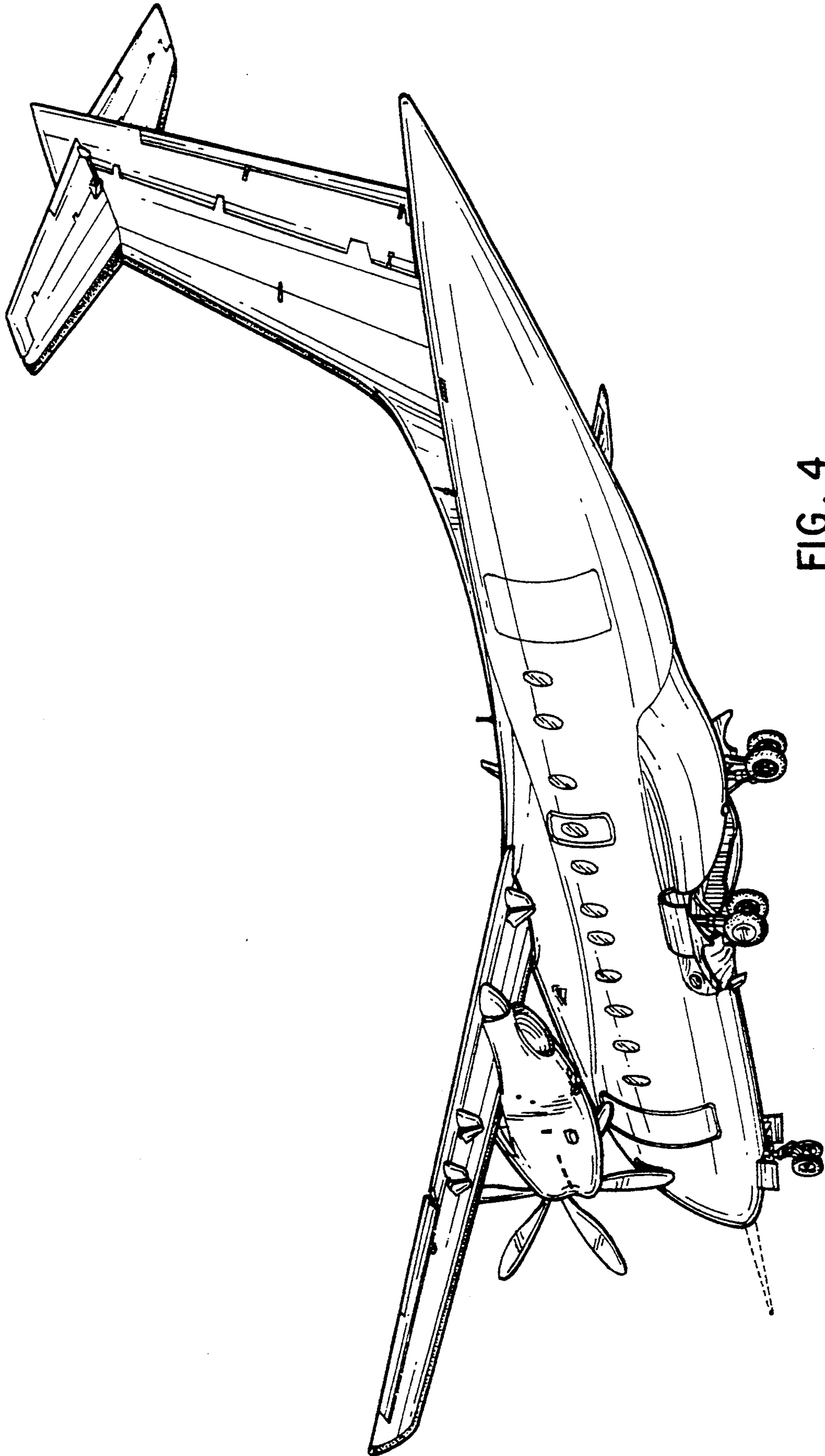

FIG. 4

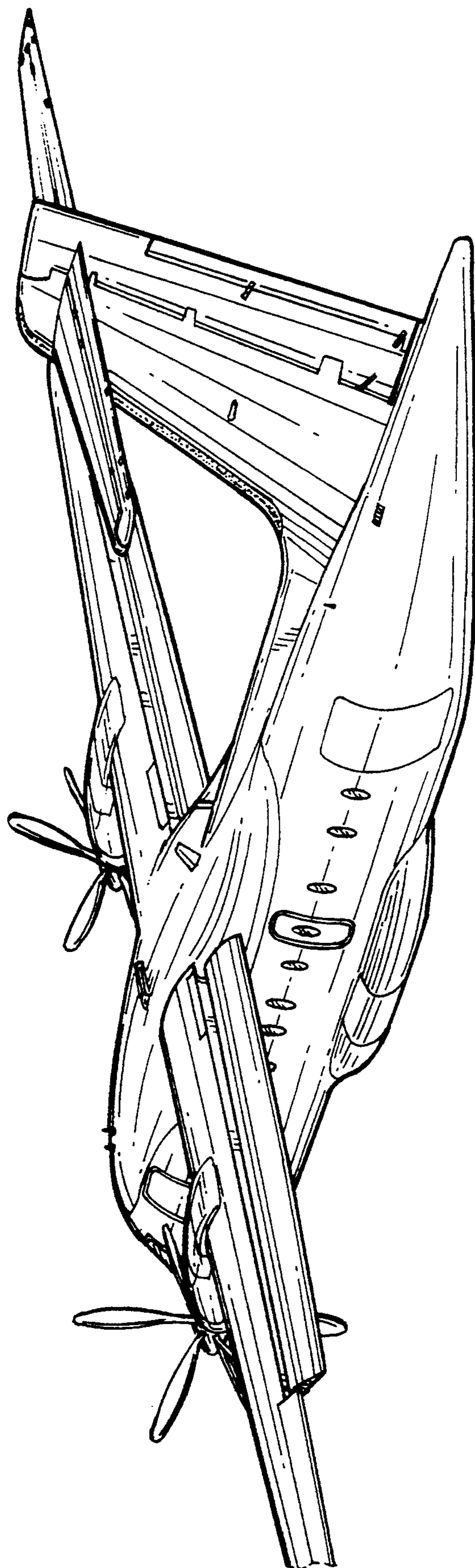

FIG. 5

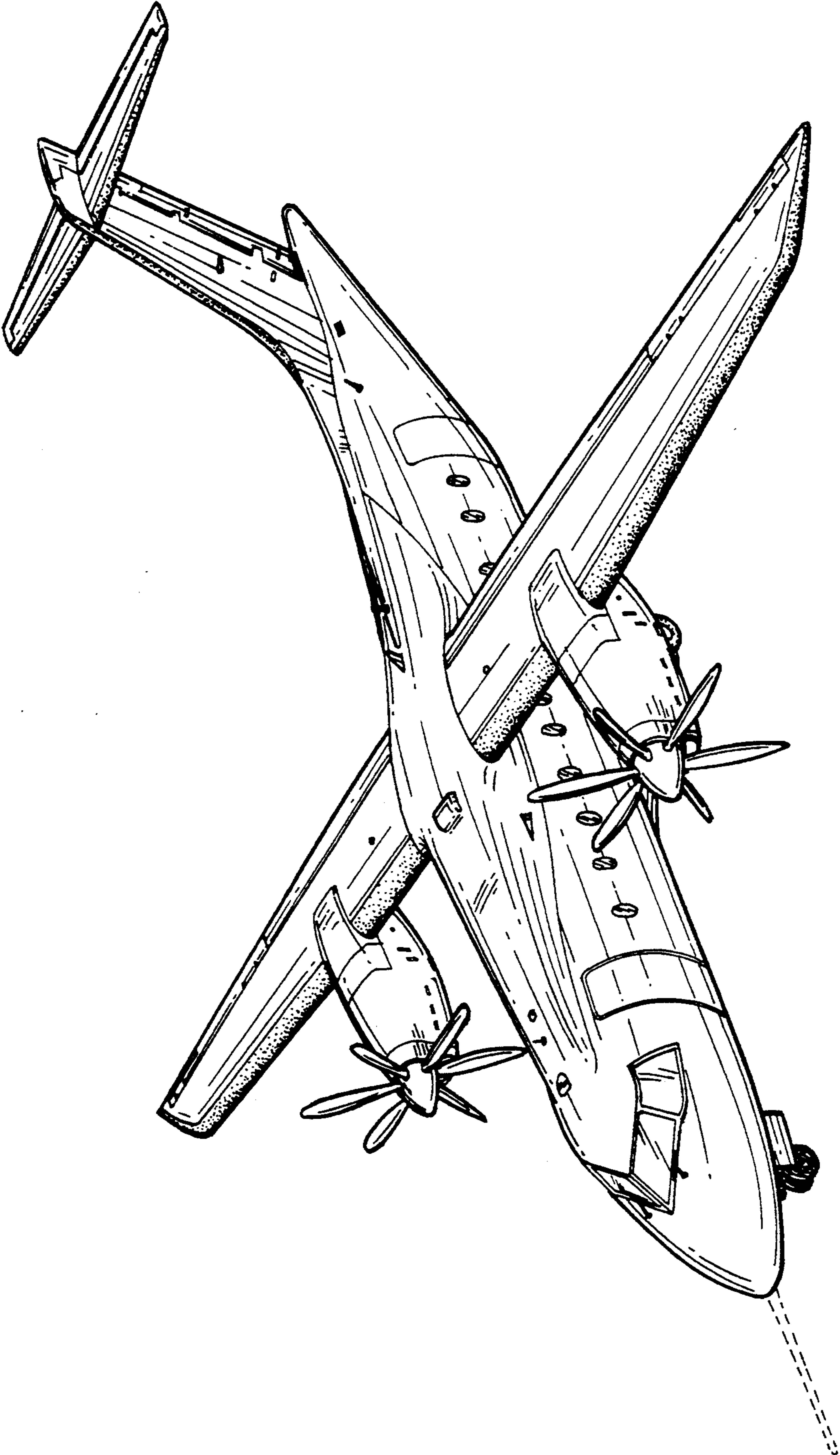

FIG. 6