



US00D352291S

# United States Patent [19]

[11] Patent Number: **Des. 352,291**

Ikeda et al.

[45] Date of Patent: **\*\* Nov. 8, 1994**

[54] COMPRESSOR FOR A VEHICLE AIR CONDITIONER

D. 282,471	2/1986	Bearint et al.	.....	D15/9
4,190,402	2/1980	Meece et al.	.....	417/415
4,248,050	2/1981	Durenec	.....	417/415
4,373,876	2/1983	Nemoto	.....	417/539

[75] Inventors: **Hayato Ikeda; Muneharu Murase; Mitsuhiro Hattori; Koichi Ito**, all of Kariya, Japan

*Primary Examiner*—Ralf T. Seifert  
*Attorney, Agent, or Firm*—Brooks Haidt Haffner & Delahunty

[73] Assignee: **Kabushiki Kaisha Toyoda Jidoshokki Seisakusho**, Kariya, Japan

### [57] CLAIM

[\*\*] Term: **14 Years**

The ornamental design for a compressor for a vehicle air conditioner, as shown and described.

[21] Appl. No.: **787,325**

### DESCRIPTION

[22] Filed: **Nov. 1, 1991**

[52] U.S. Cl. .... **D15/7**

[58] Field of Search ..... 417/415, 419, 529, 533, 417/534, 539, 272, 231, 259, 205, 234; D15/1-9.2

FIG. 1 is a left side view of a compressor for a vehicle air conditioner;  
 FIG. 2 is a right side view thereof;  
 FIG. 3 is a front view thereof;  
 FIG. 4 is a bottom view thereof;  
 FIG. 5 is a rear view thereof;  
 FIG. 6 is a plan view thereof;  
 FIG. 7 is a front perspective view thereof; and,  
 FIG. 8 is a rear perspective view thereof.

### [56] References Cited

#### U.S. PATENT DOCUMENTS

D. 245,779	9/1977	Nobata	.....	D15/9
D. 273,587	4/1984	Hodgson	.....	D15/9

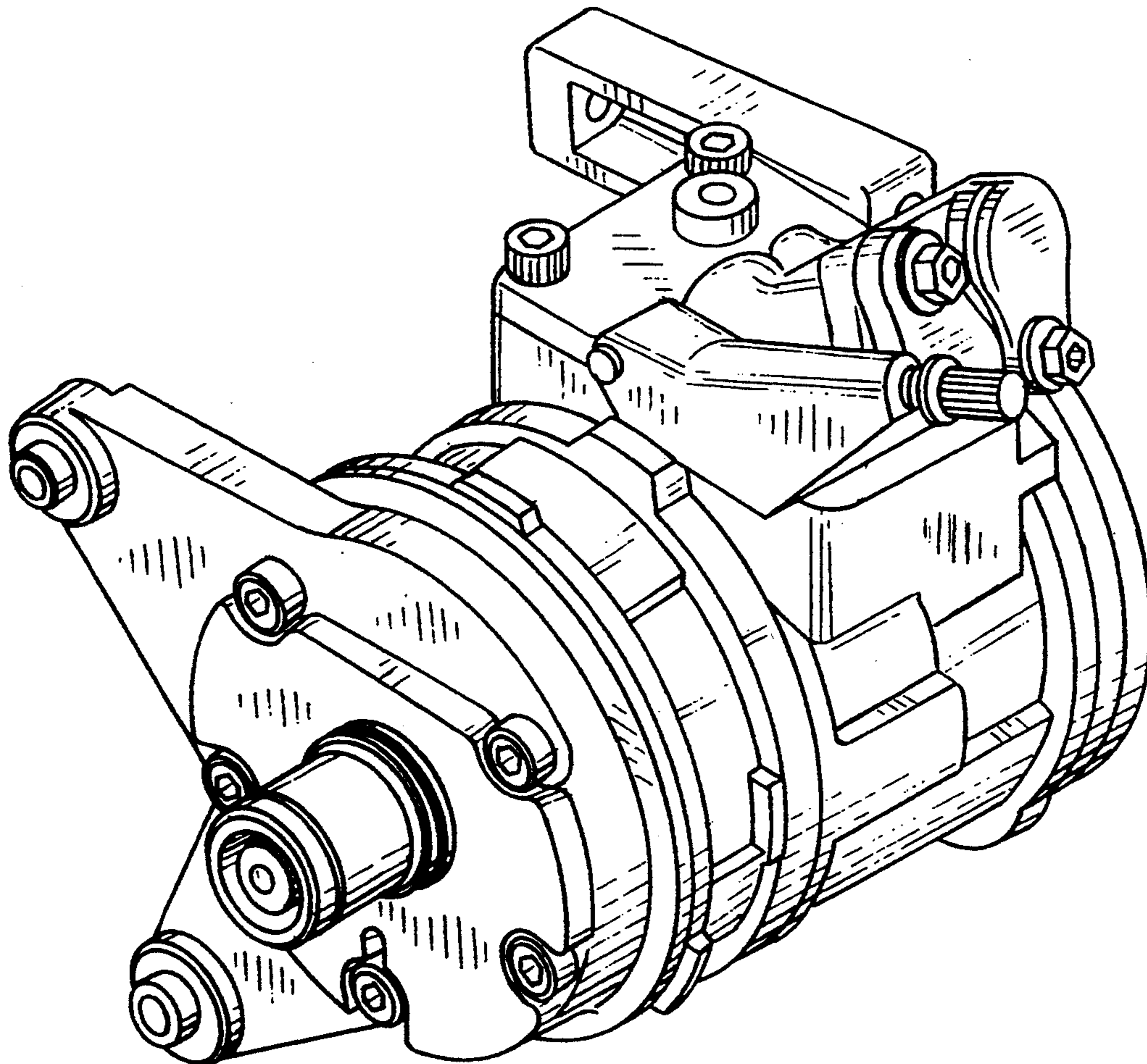

FIG. 1

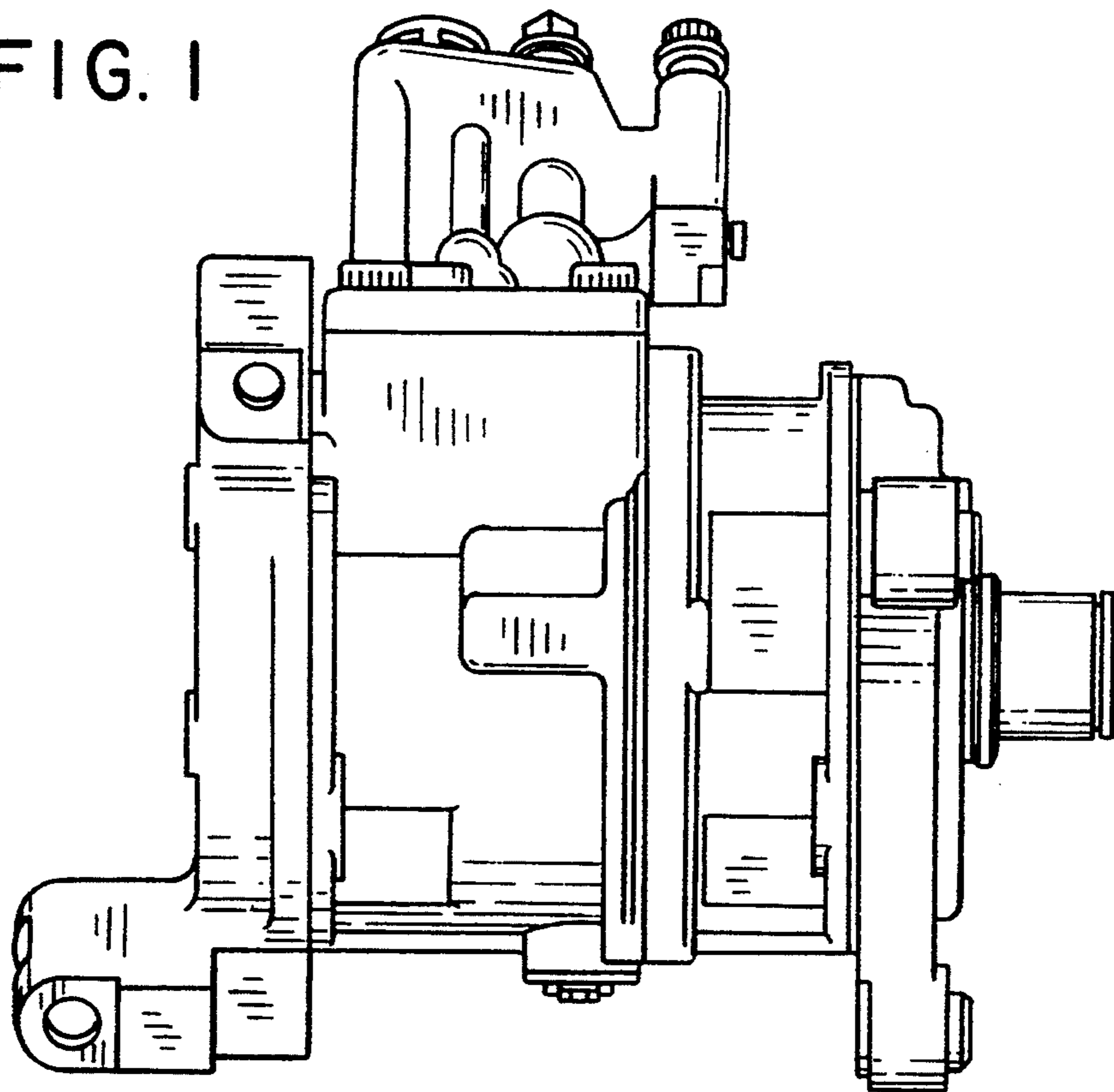

FIG. 2

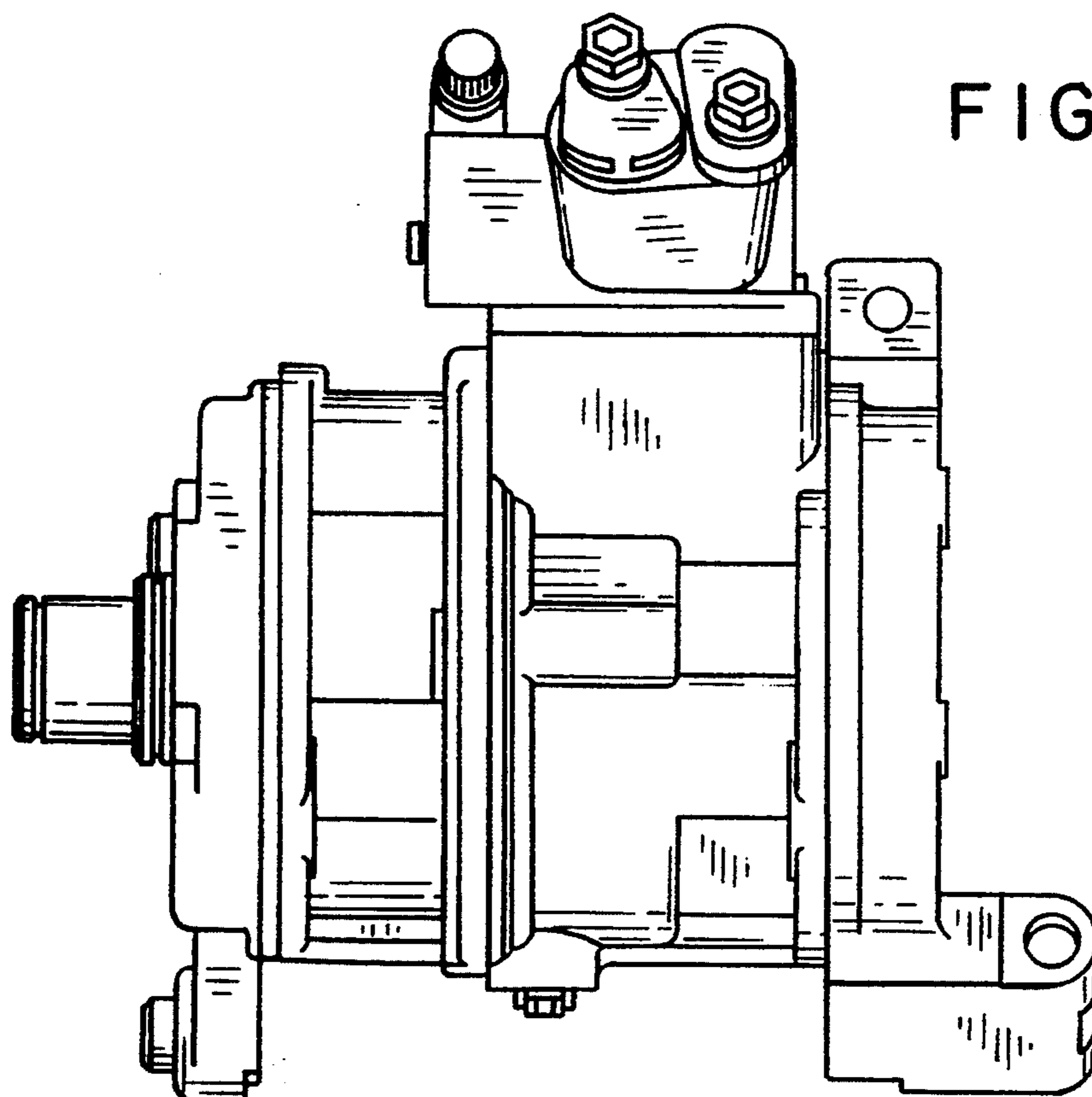

FIG. 3

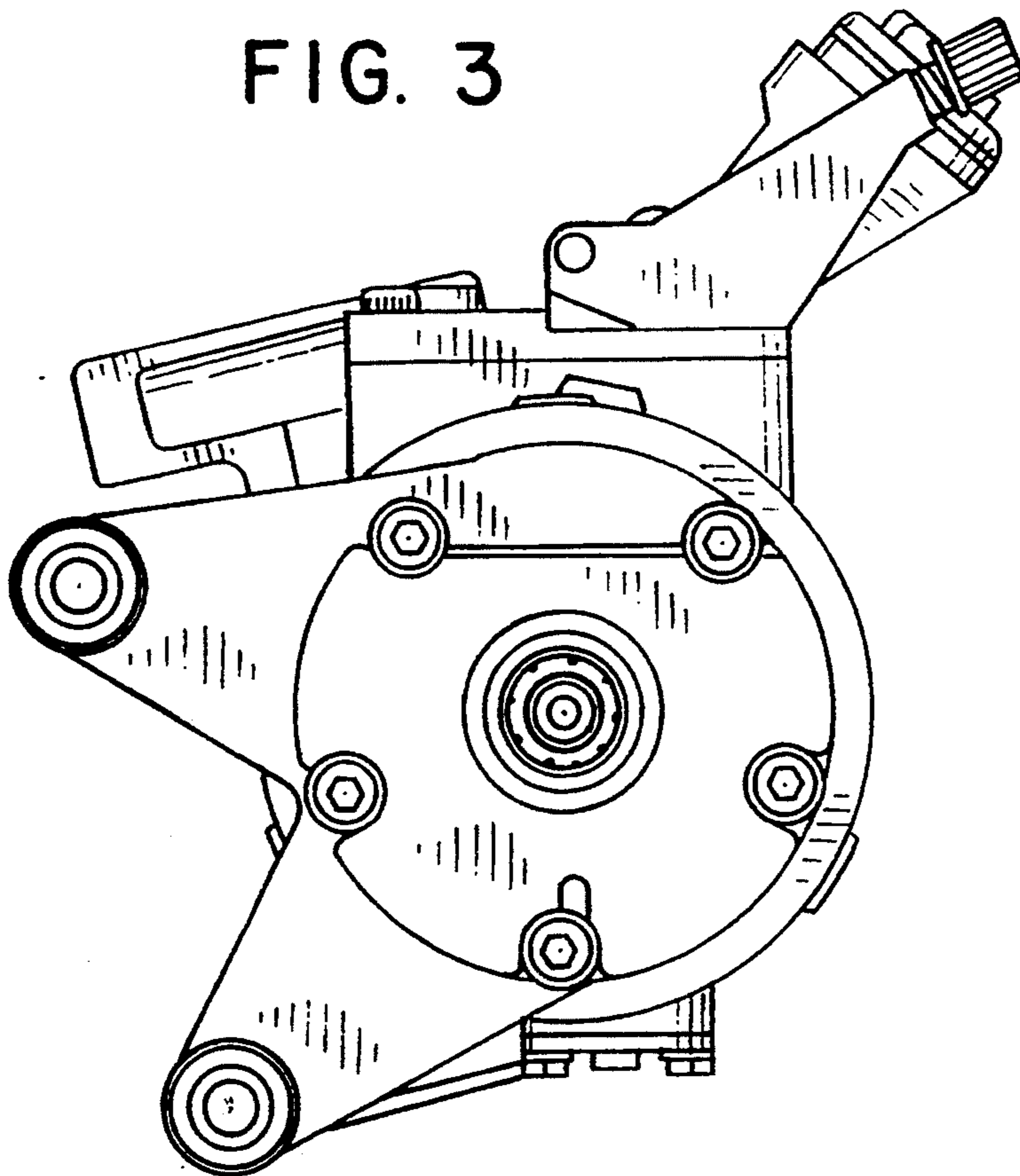
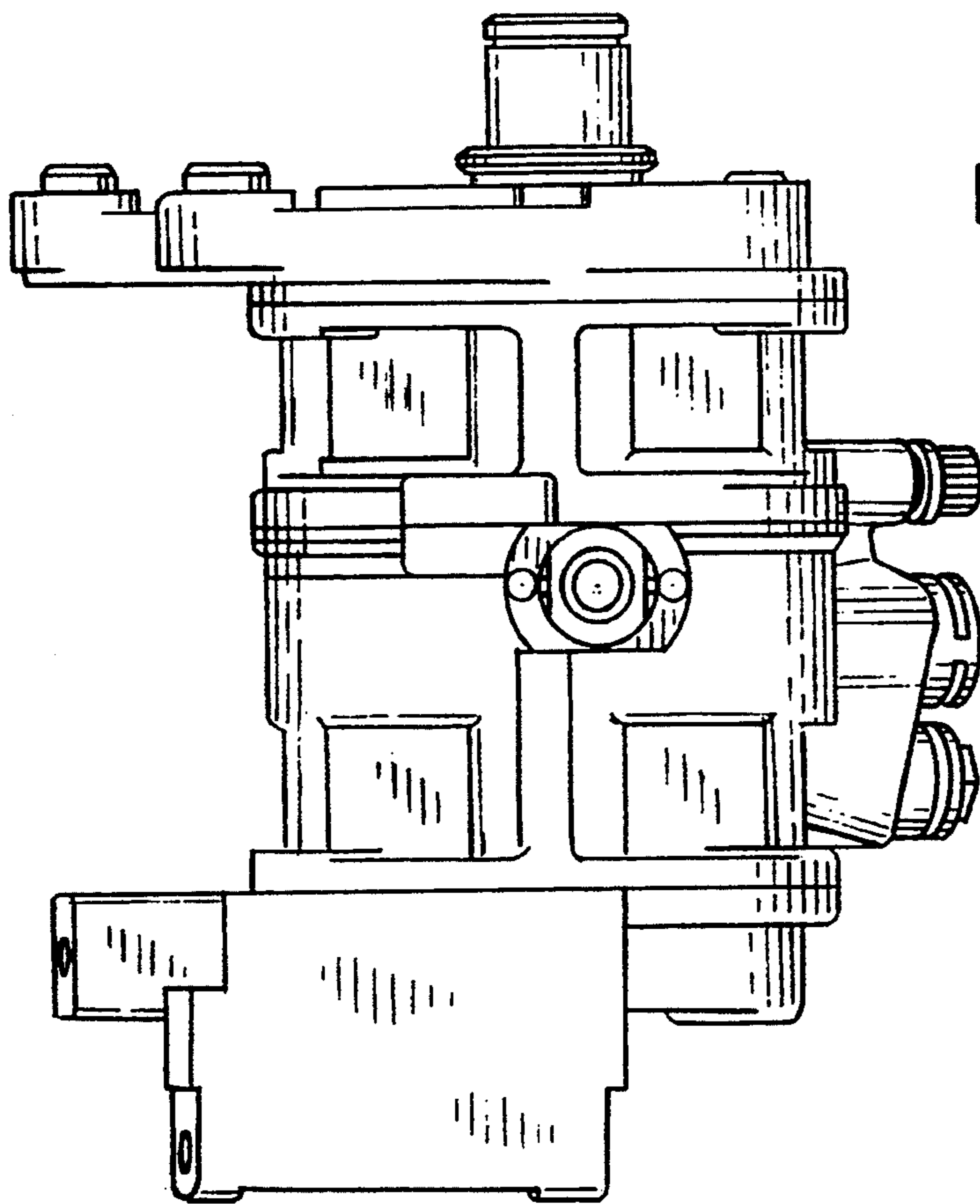

FIG. 4



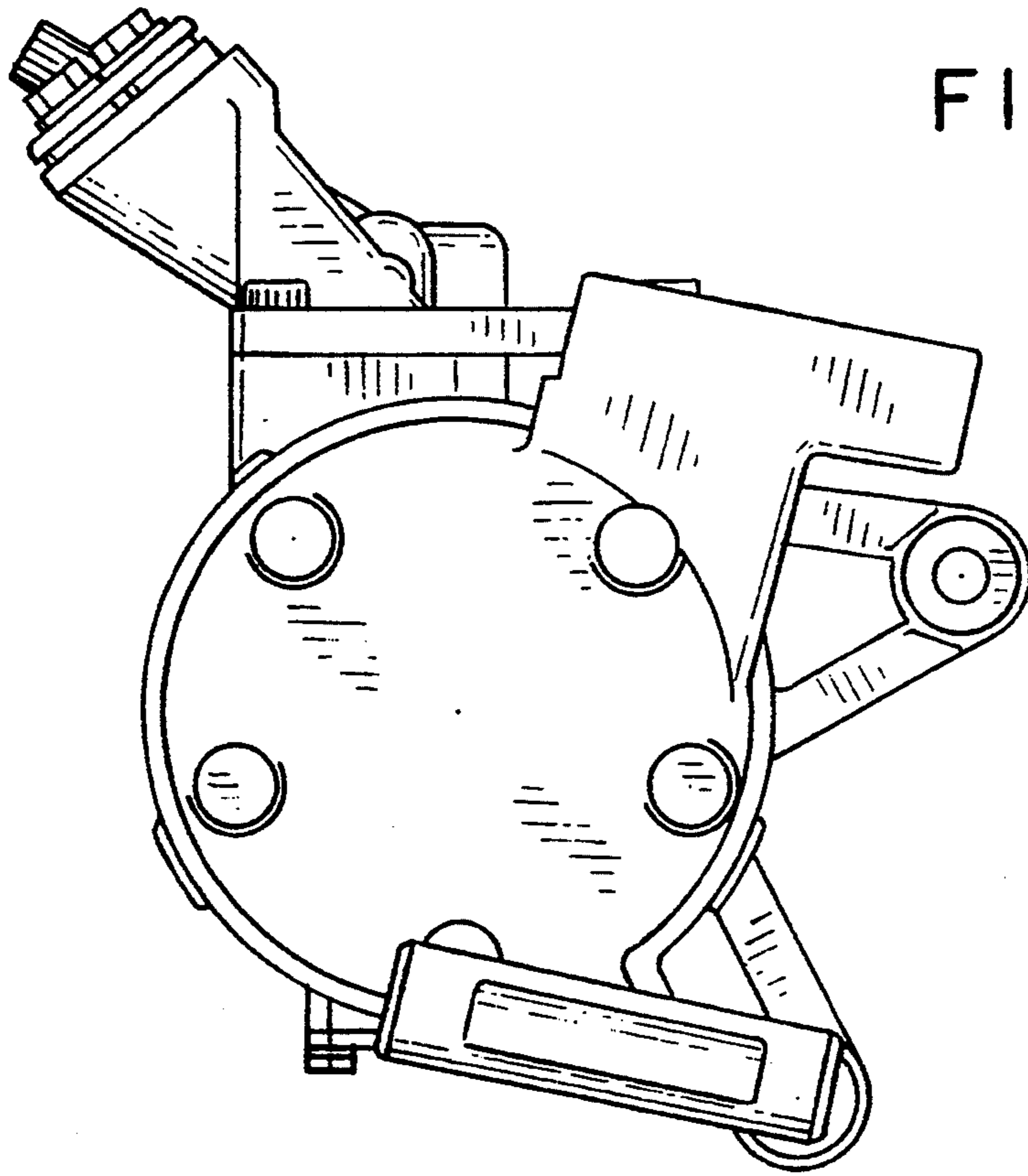

FIG. 5

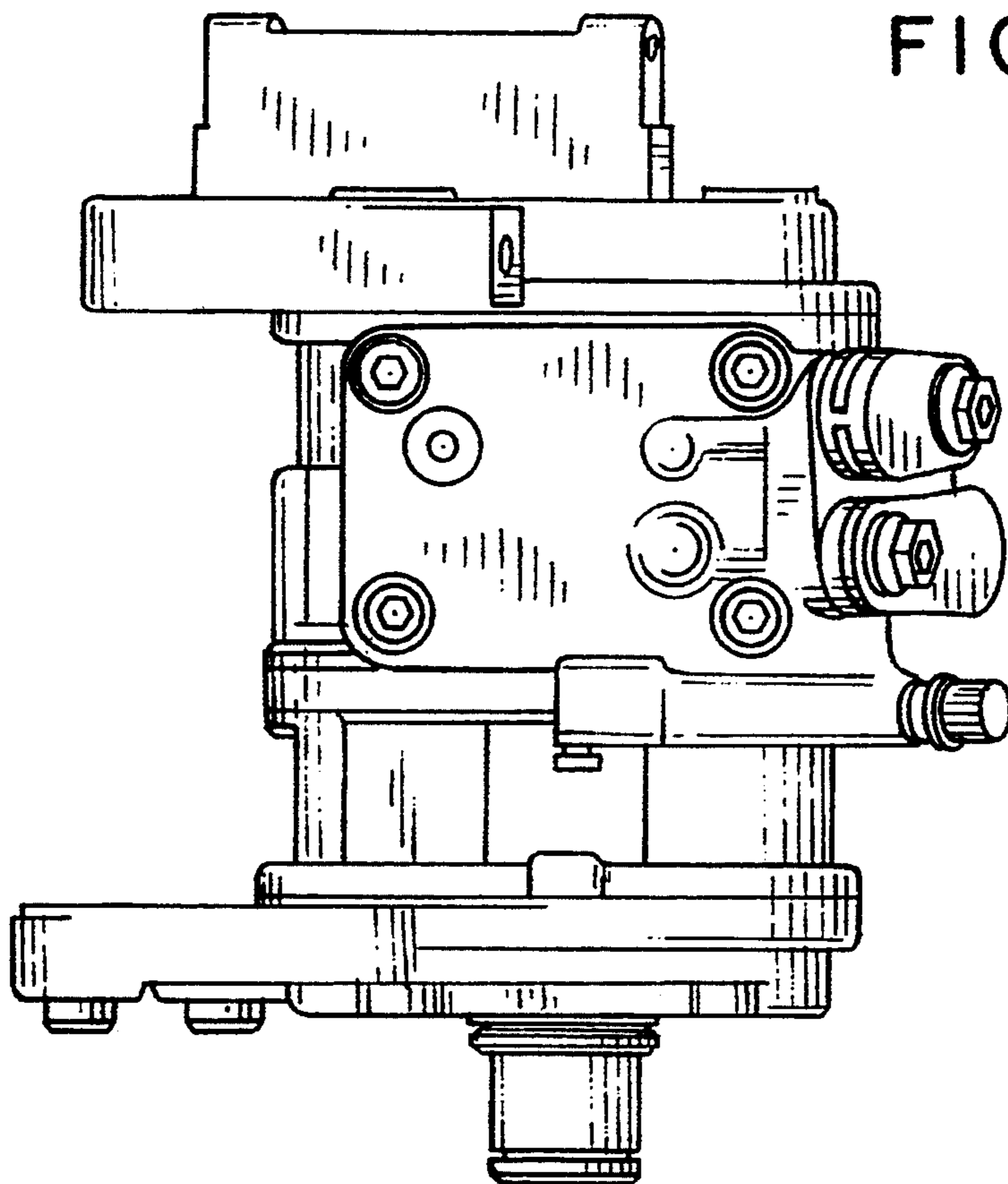
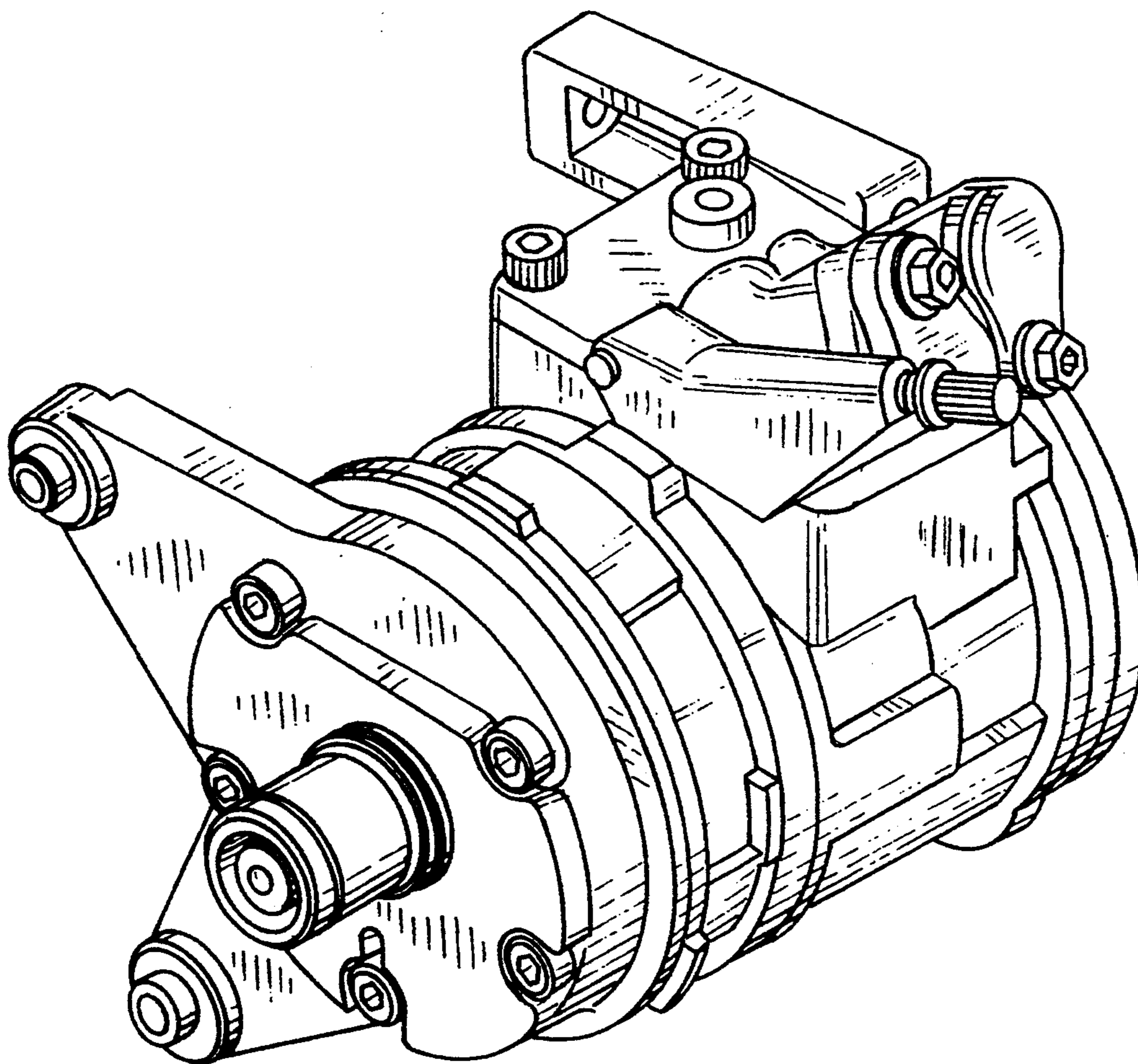

FIG. 6

FIG. 7



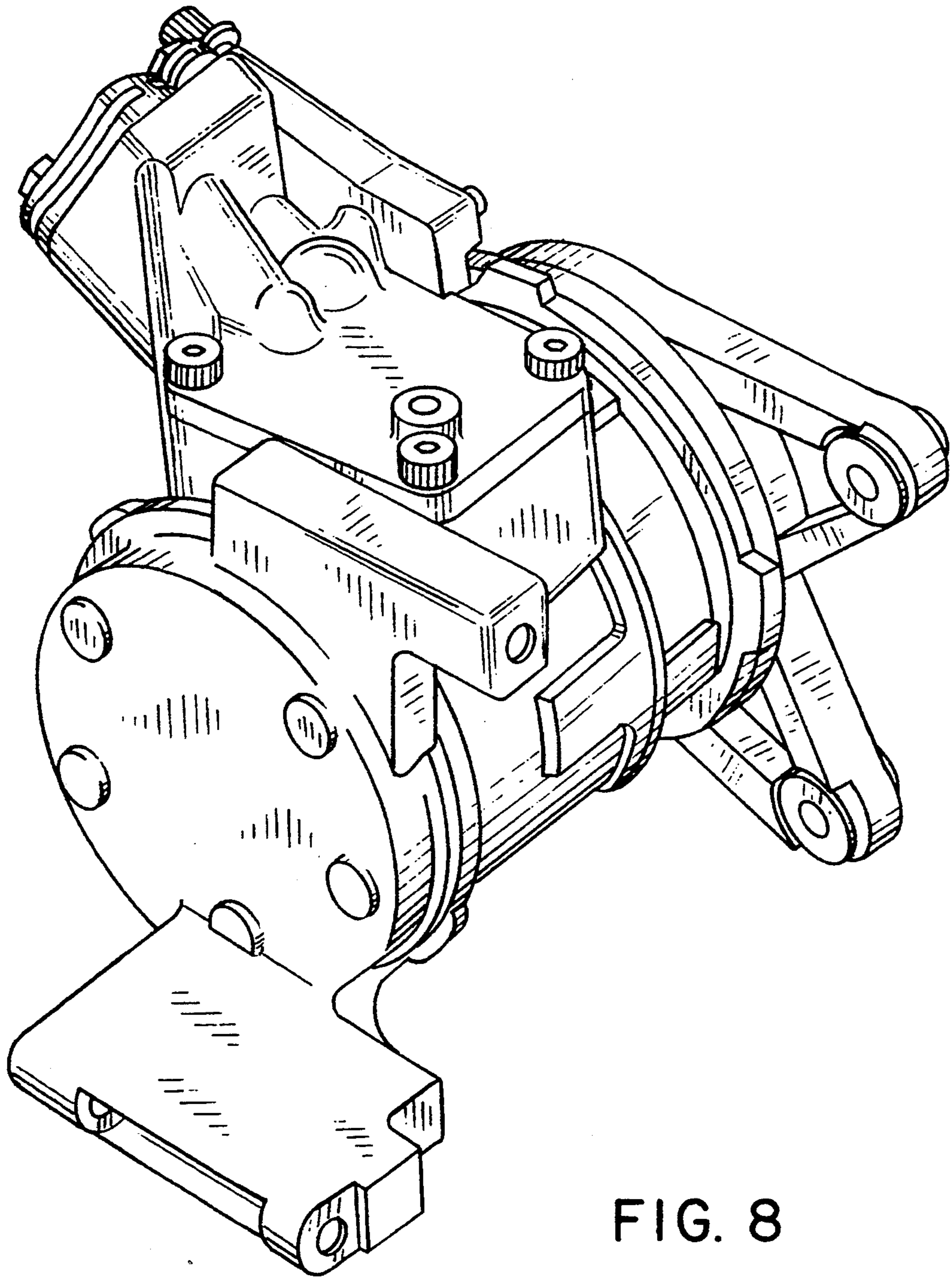

FIG. 8