



US00D352265S

United States Patent [19]

[11] Patent Number: **Des. 352,265**

Haney et al.

[45] Date of Patent: **** Nov. 8, 1994**

[54] **BOAT MOTOR PROPELLER AND SKEG GUARD**

5,078,630	1/1992	Katsumoto	440/88
5,178,565	1/1993	Jacobson	440/71
5,224,889	7/1993	Hickey	440/71

[76] Inventors: **Michael G. Haney**, 1311 Cypress Dr., Richardson, Tex. 75080; **Neill H. Watt**, 9029 Diceman Dr., Dallas, Tex. 75218

Primary Examiner—Kay H. Chin
Attorney, Agent, or Firm—Ross, Howison, Clapp & Korn

[**] Term: **14 Years**

[57] **CLAIM**

[21] Appl. No.: **13,220**

The ornamental design for boat motor propeller and skeg guard, as shown and described.

[22] Filed: **Sep. 21, 1993**

DESCRIPTION

[52] U.S. Cl. **D12/214**

[58] Field of Search 440/71, 49, 51, 88; 416/245 A, 244 B; D12/214, 345, 317

FIG. 1 is a left side view of our new design, the broken lines showing the lower portion of a boat motor, skeg guard, and propeller are for illustrative purposes only and form no part of the claimed design; FIG. 2 is a front elevational view thereof; FIG. 3 is a top plan view thereof; FIG. 4 is a right side view thereof; FIG. 5 is a rear elevational view thereof; and, FIG. 6 is a bottom plan view thereof.

[56] **References Cited**

U.S. PATENT DOCUMENTS

2,717,570	9/1955	Willoughby	115/42
2,894,477	7/1959	Brown	115/42
4,096,819	6/1978	Evinrude	115/17
4,235,183	11/1980	Evinrude	440/71

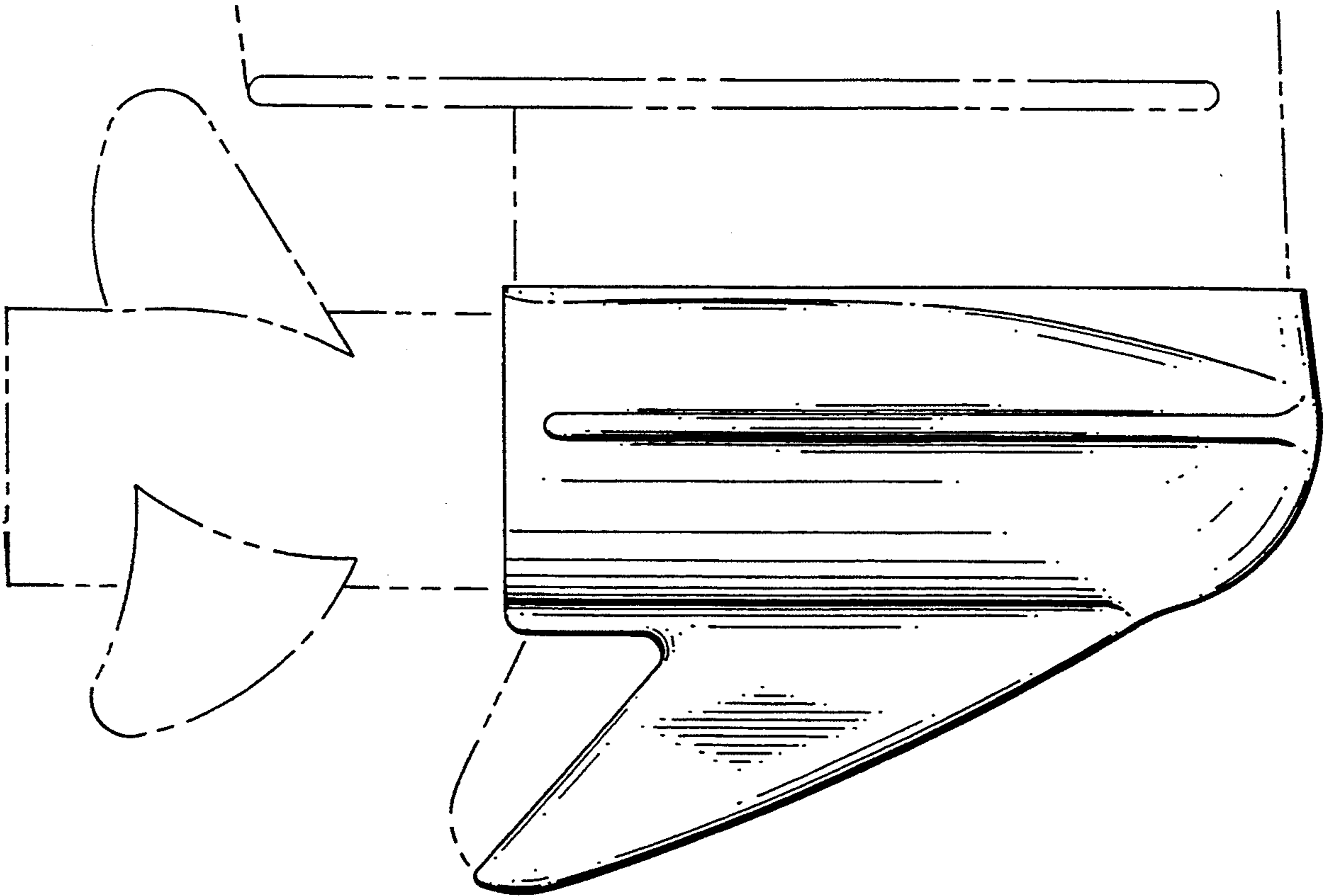

FIG. 1

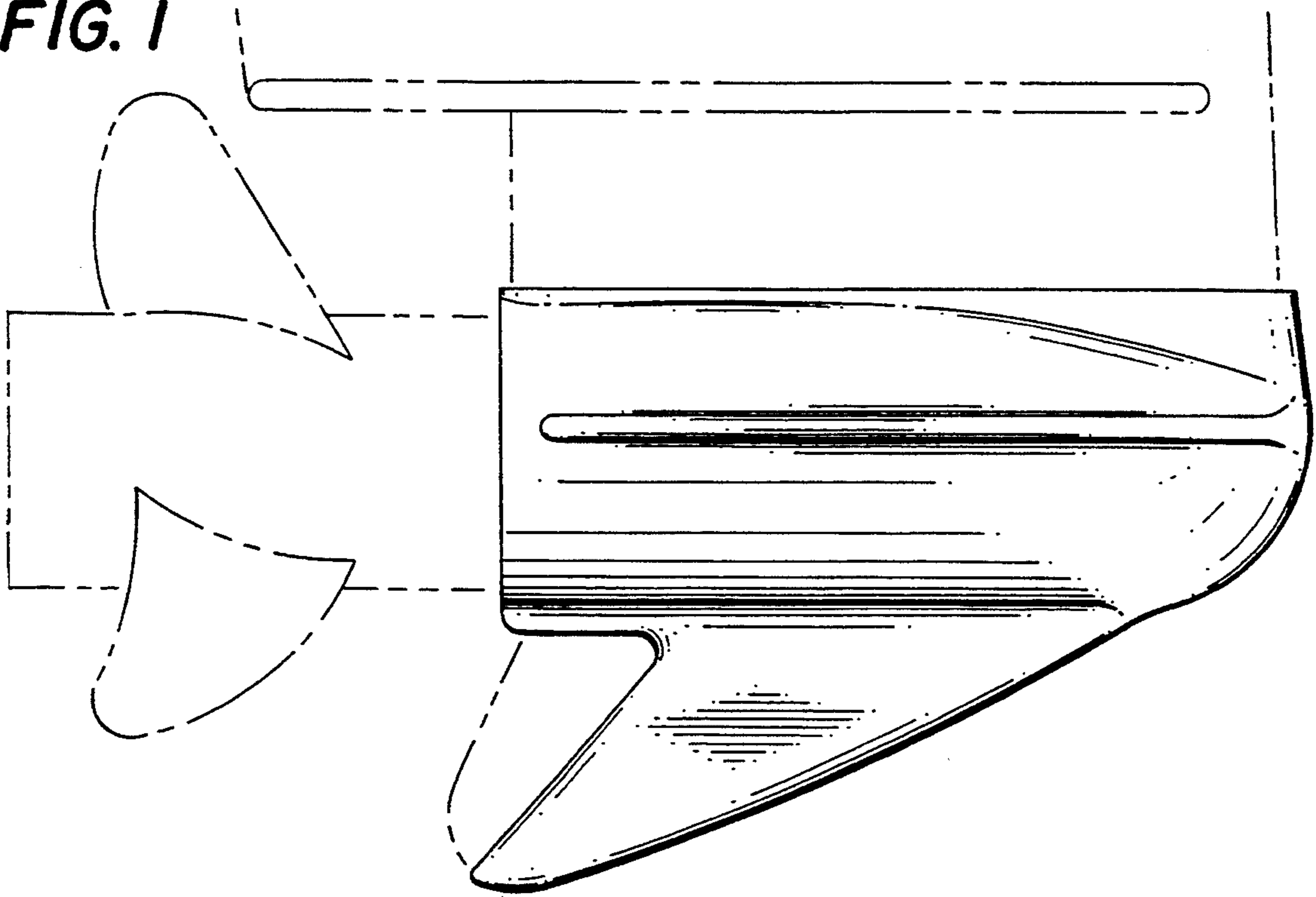

FIG. 2

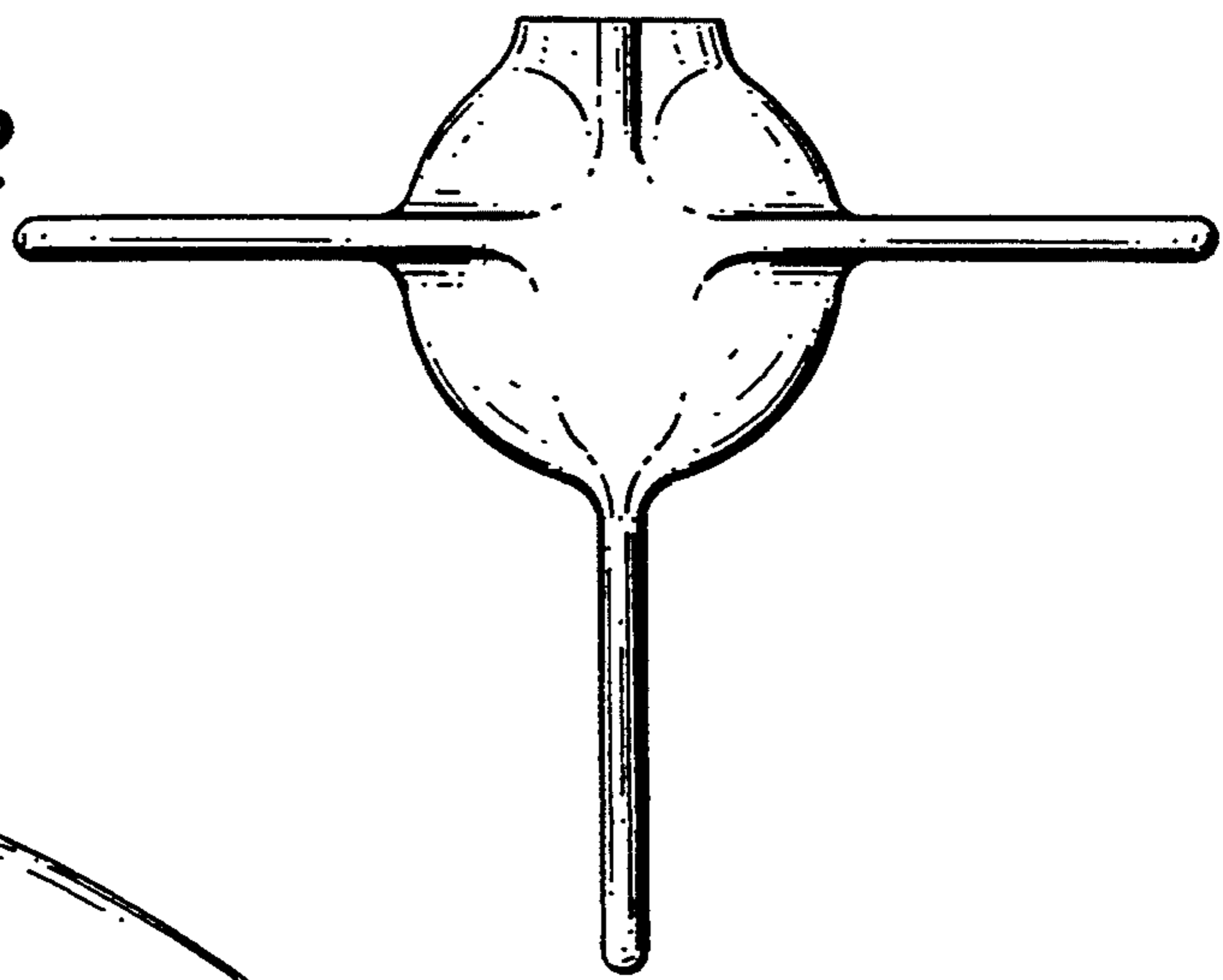

FIG. 3

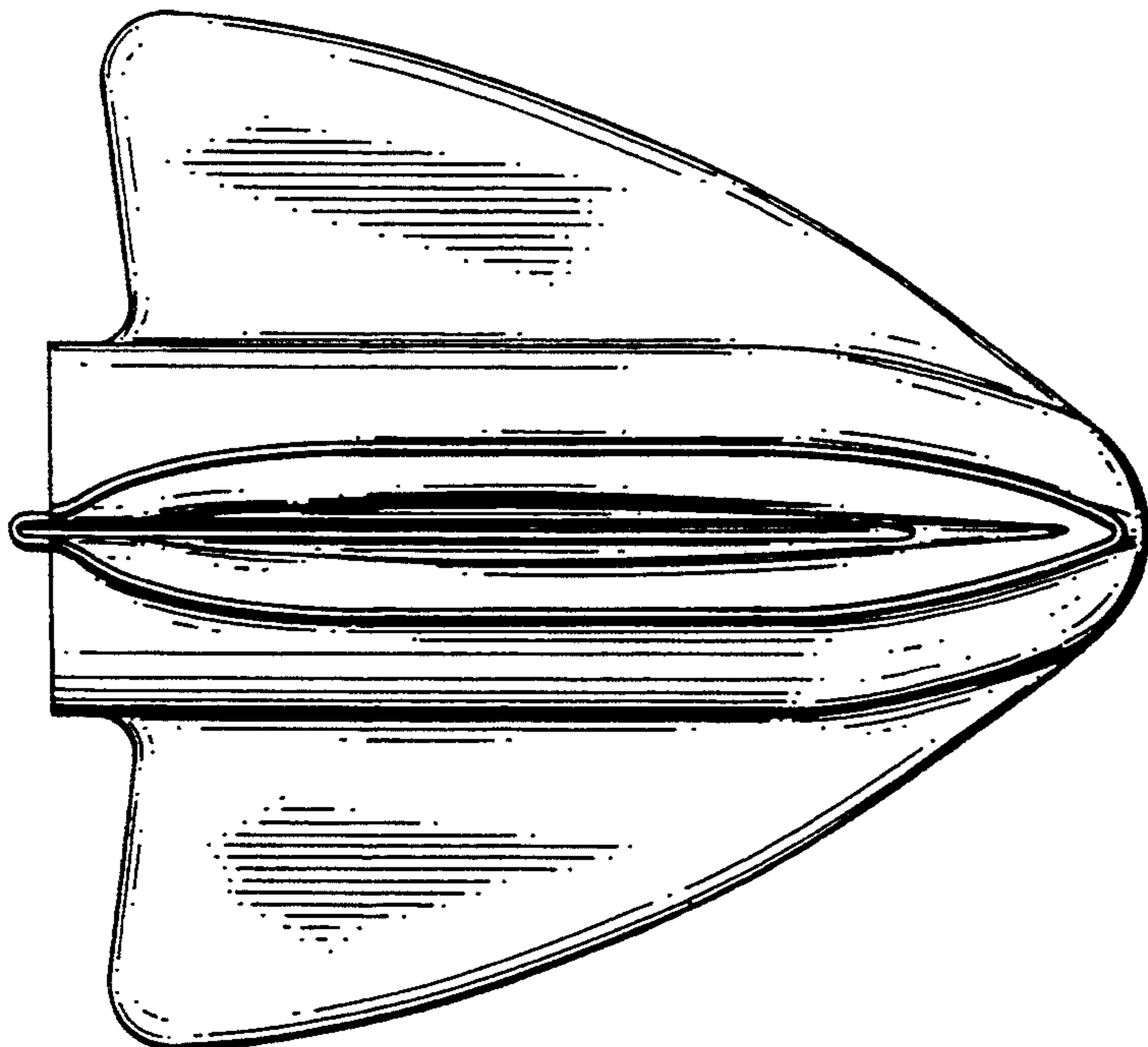

FIG. 4

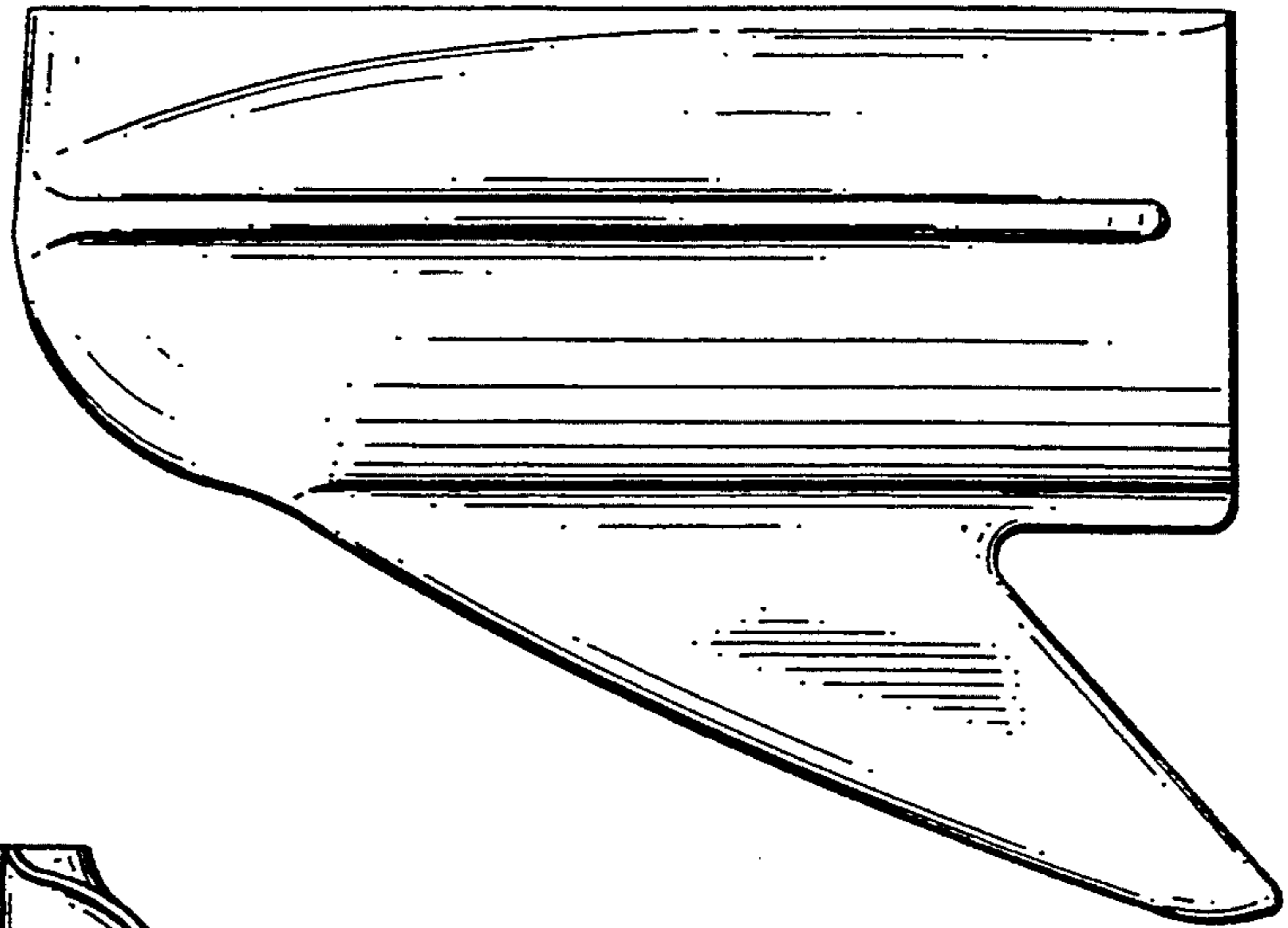

FIG. 5

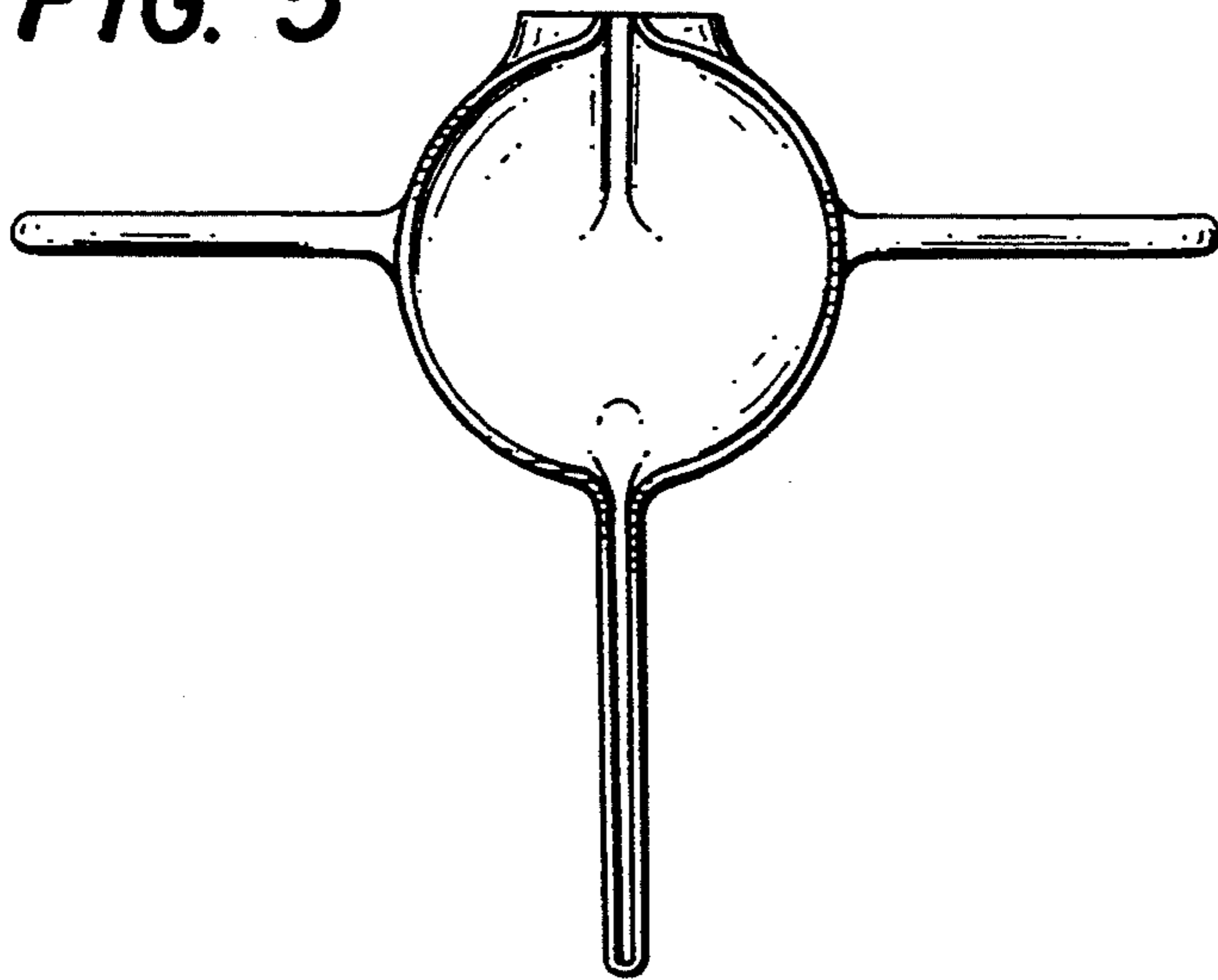

FIG. 6

