



US00D352055S

# United States Patent [19]

[11] Patent Number: Des. 352,055

Girard

[45] Date of Patent: \*\* Nov. 1, 1994

[54] **COMBINED PORTABLE PRINTER, SHEET FEEDER AND BASE**

[75] Inventor: **James J. Girard**, Boise, Id.

[73] Assignee: **Hewlett-Packard Company**, Palo Alto, Calif.

[\*\*] Term: **14 Years**

[21] Appl. No.: **882,101**

[22] Filed: **May 11, 1992**

[52] U.S. Cl. .... **D18/50; D18/49**

[58] Field of Search ..... 400/690-694, 400/690.1-690.4, 613, 613.1-613.4; D18/6, 11, 19, 34, 46, 49, 50, 52-55; D14/100, 106

[56] **References Cited**

**U.S. PATENT DOCUMENTS**

- D. 293,445 12/1987 Pensavecchia ..... D18/55
- D. 307,157 4/1990 Sakaguchi et al. .... D18/54
- D. 321,898 11/1991 Kasee et al. .... D18/55
- D. 330,385 10/1992 Umino ..... D18/49
- D. 333,835 3/1993 Israely et al. .... D18/55
- D. 339,159 9/1993 Pruitt et al. .... D18/55
- 4,723,857 2/1988 Yokoi ..... D18/55
- 4,828,416 5/1989 Pensavecchia et al. .... 400/691
- 4,904,100 2/1990 Enix ..... 400/613
- 5,028,935 7/1991 Warmack et al. .... D18/55
- 5,061,097 10/1991 Piatt ..... 400/691

**FOREIGN PATENT DOCUMENTS**

- 6787 1/1991 Canada ..... D18/400 50

**OTHER PUBLICATIONS**

PC Magazine; Jul. 1989; p. 53; Toshiba Thermal Printer Advertisement.

Canon BJ-10e Bubble Jet Printer w/Automatic Paper Feeder; p. 4.

Primary Examiner—Cathy Anne MacCormac

[57] **CLAIM**

The ornamental design for a combined portable printer, sheet feeder and base, as shown and described.

**DESCRIPTION**

FIG. 1 is a front, top and right side perspective view of the printer shown in FIG. 3;  
 FIG. 2 is a rear bottom and left side perspective view of the printer shown in FIG. 3;  
 FIG. 3 is a top front and left side perspective view for a combined portable printer, sheet feeder and base showing my new design;  
 FIG. 4 is a top rear and right side perspective view thereof;  
 FIG. 5 is a bottom perspective view thereof;  
 FIG. 6 is a right side elevational view thereof, the left side can be seen in FIG. 10;  
 FIG. 7 is a front elevational view thereof;  
 FIG. 8 is a rear elevational view thereof;  
 FIG. 9 is a front perspective view of the printer and sheet feeder in an operational mode in which the paper access hatch is open 180° and the paper support arms are in their open or operational positions;  
 FIG. 10 is a rear perspective view of FIG. 9;  
 FIG. 11 is a front perspective view thereof;  
 FIG. 12 is a right side elevational view of the printer and sheet feeder in an operational mode;  
 FIG. 13 is an exploded perspective view thereof;  
 FIG. 14 is a perspective of the printer and base;  
 FIG. 15 is a perspective view of the paper access hatch with the paper support arms in their closed or nested positions;  
 FIG. 16 is a perspective view of the paper access hatch with the paper support arms in their open or operational positions; and,  
 FIG. 17 is a top perspective view of the base, the bottom can be seen in FIG. 5.

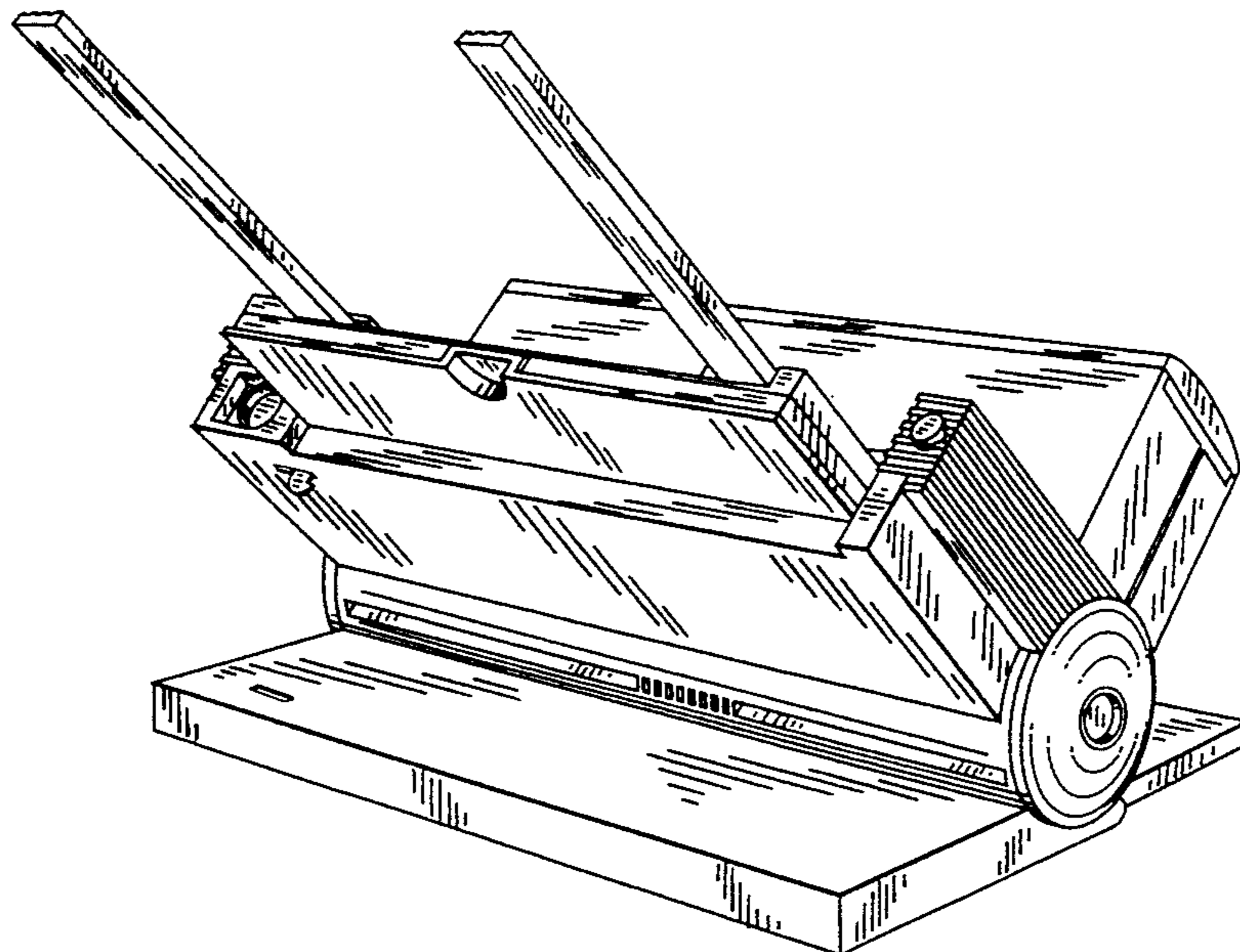

FIG. 1

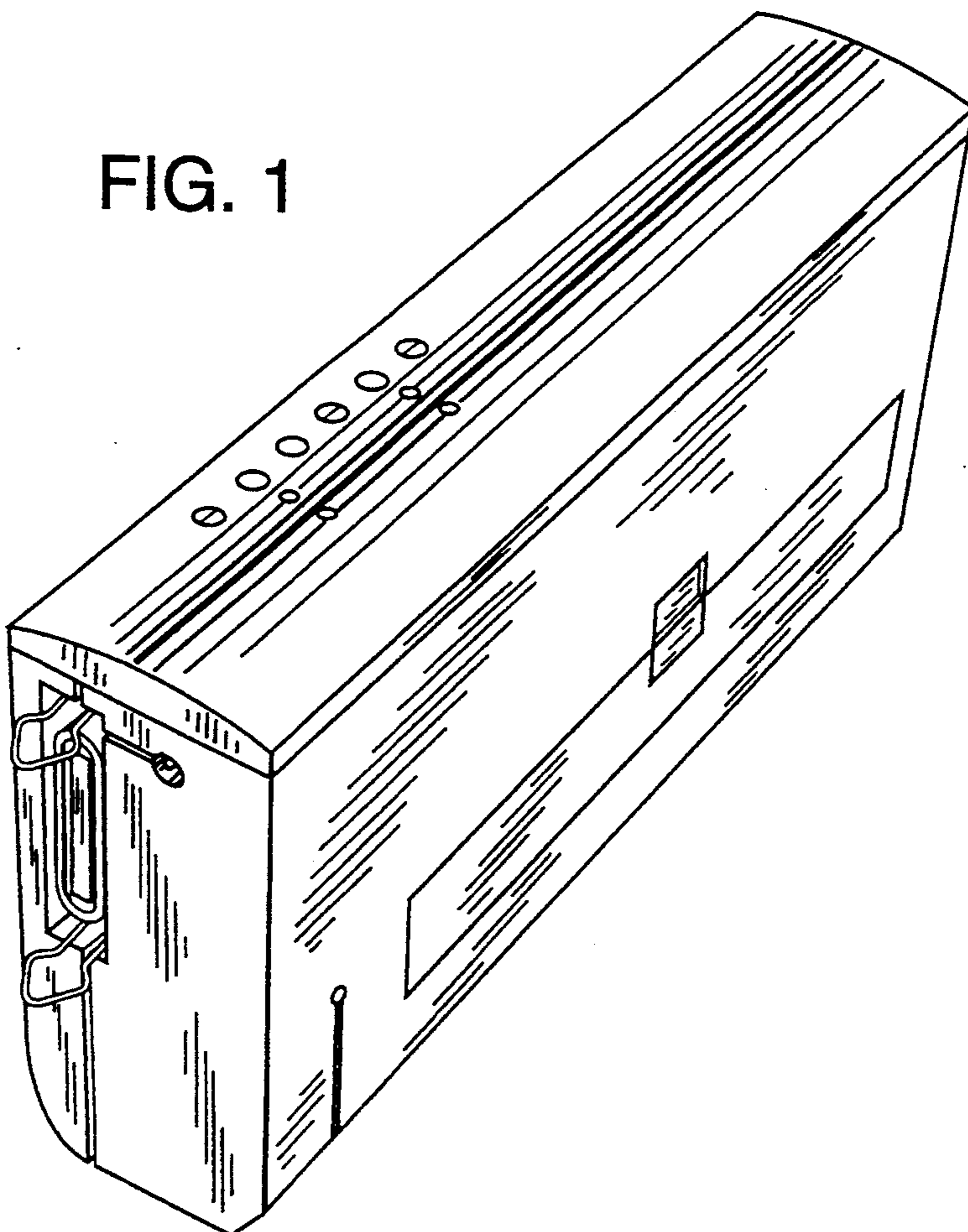

FIG. 2

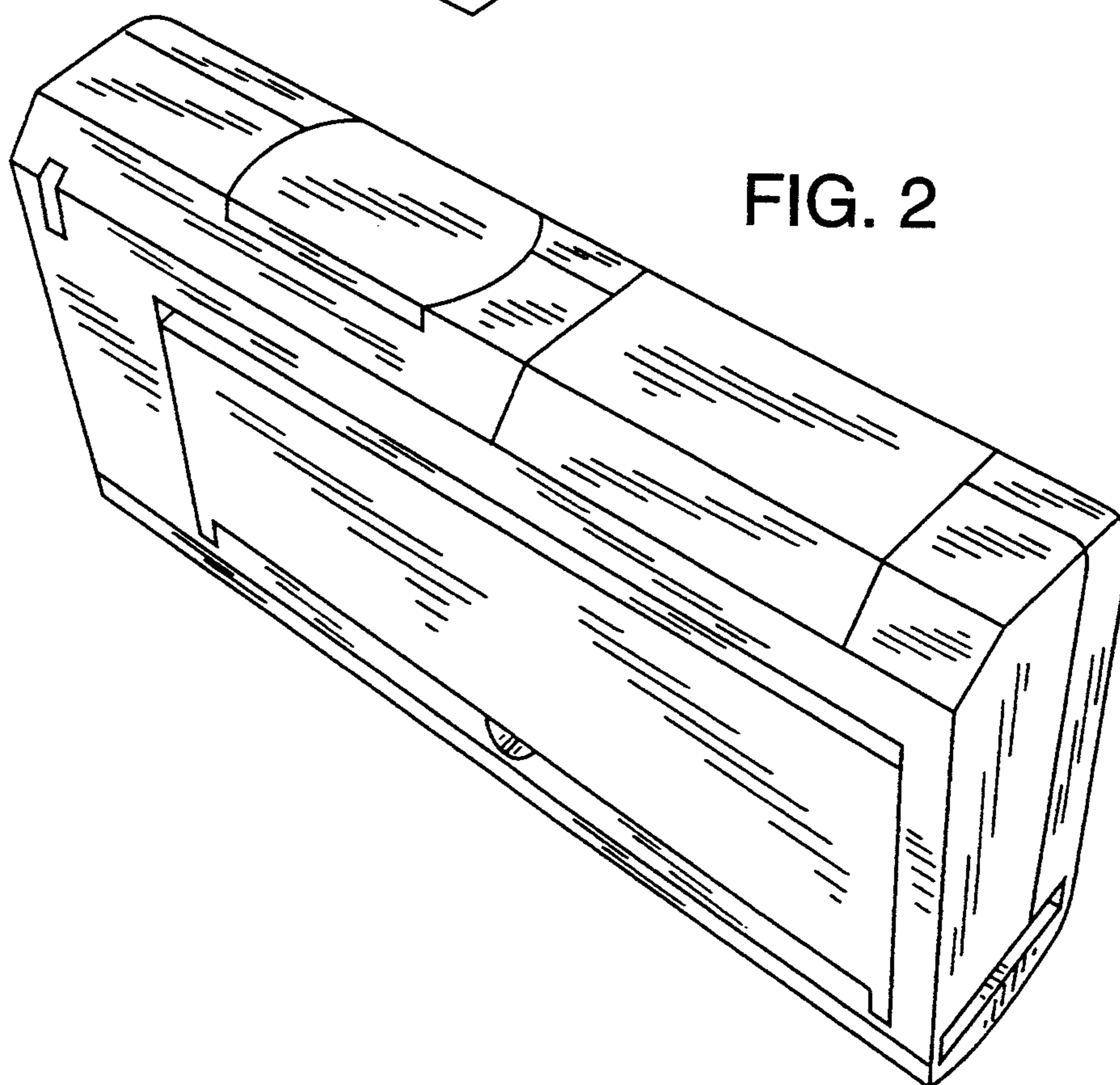

FIG. 3

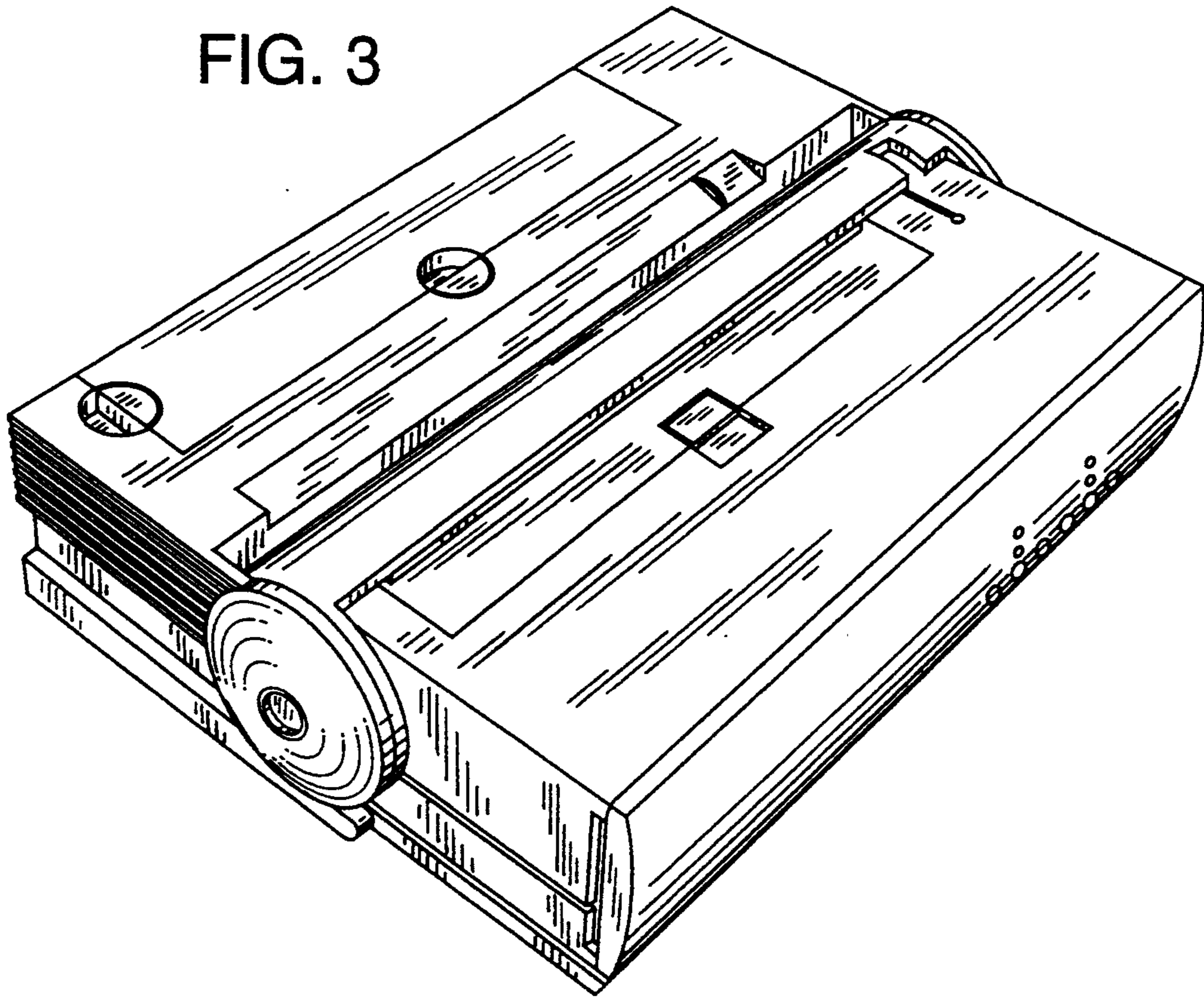

FIG. 4

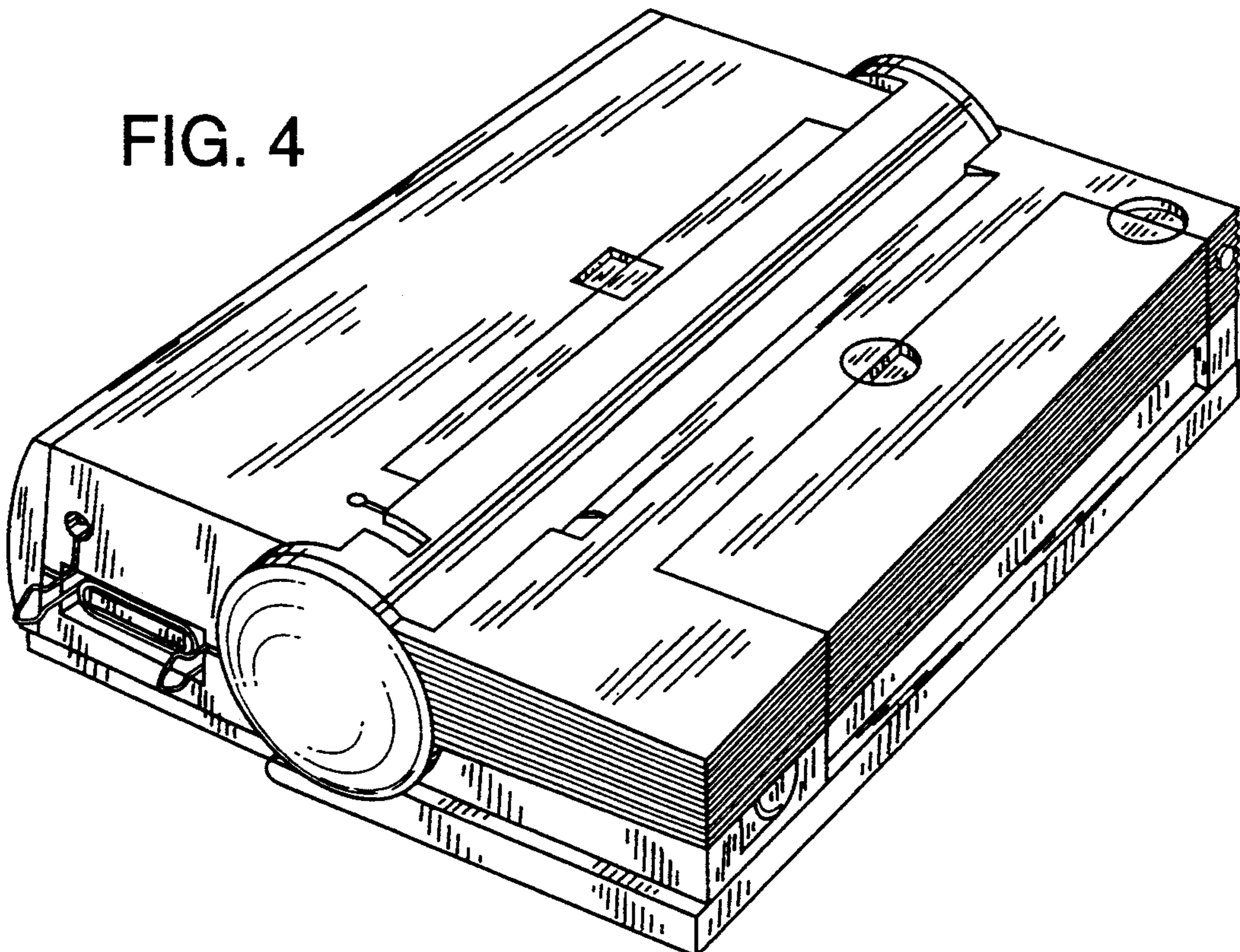

FIG. 5

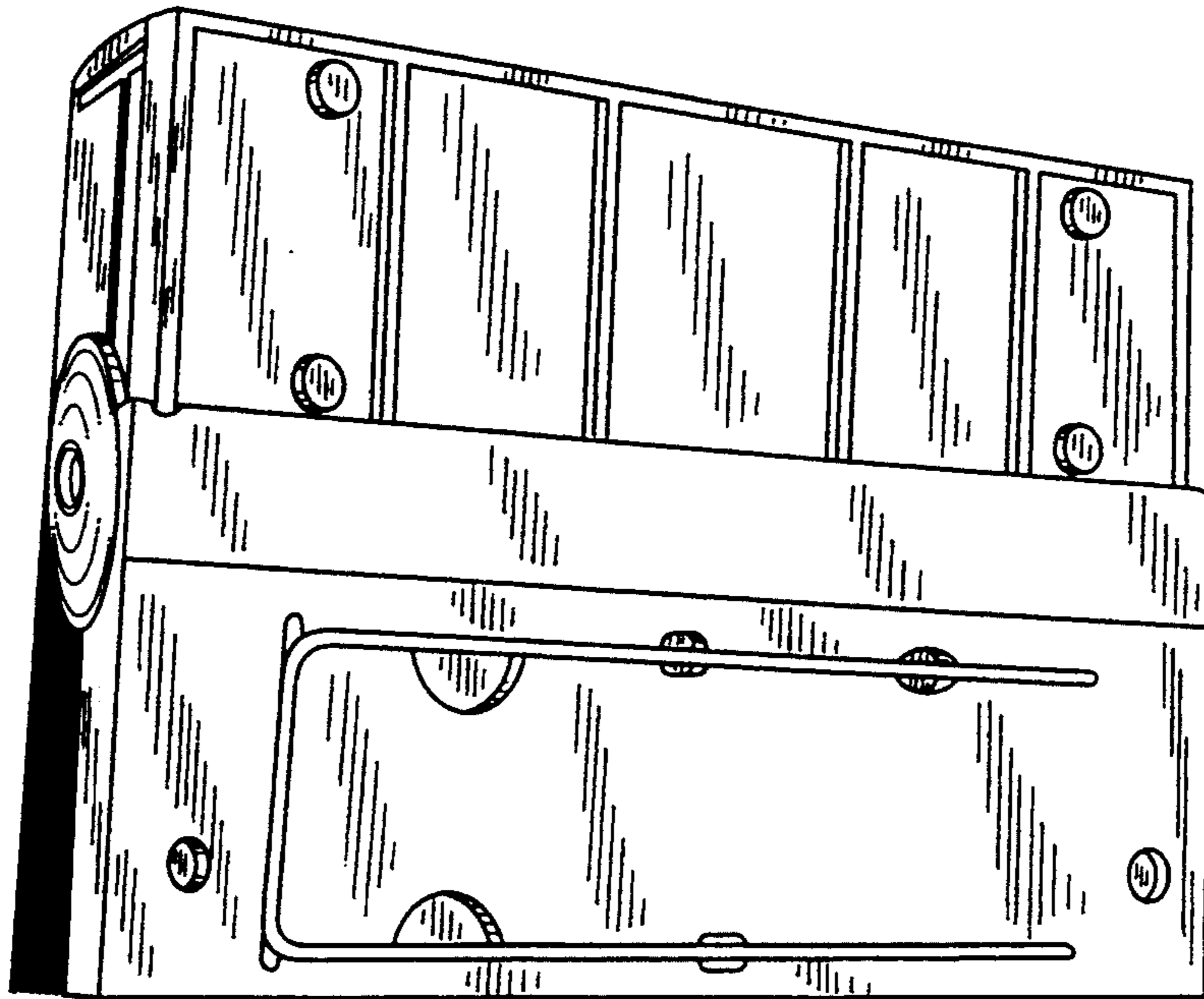

FIG. 6

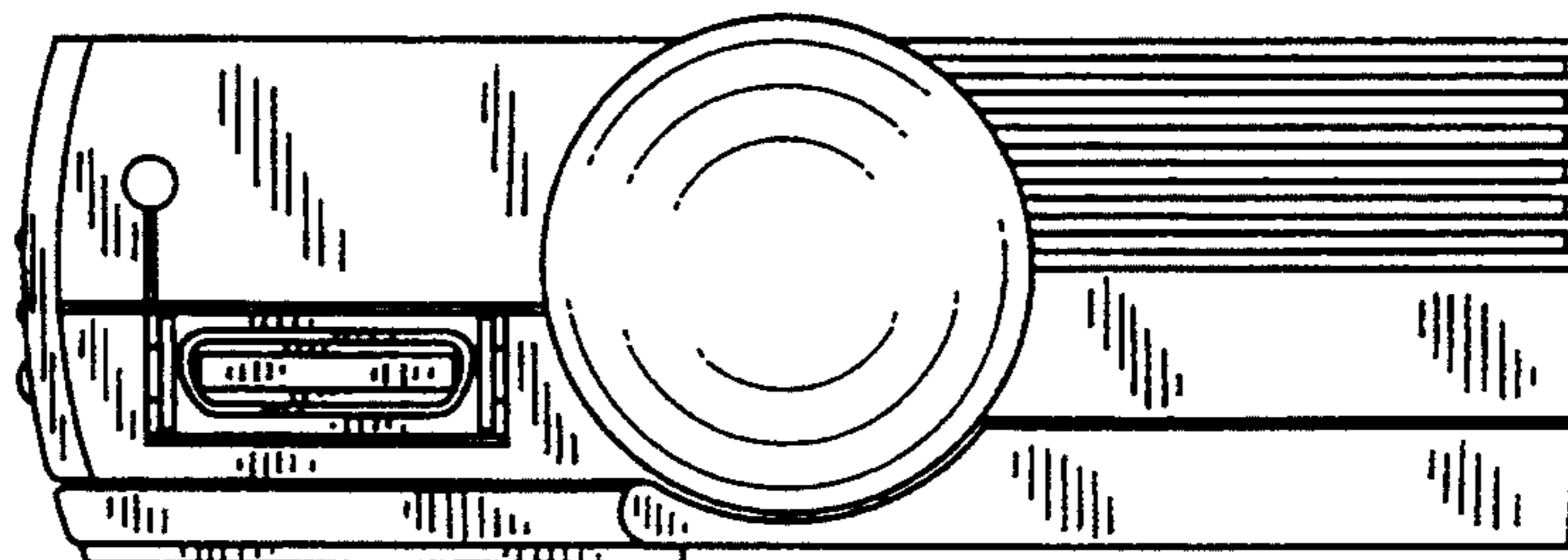

FIG. 7

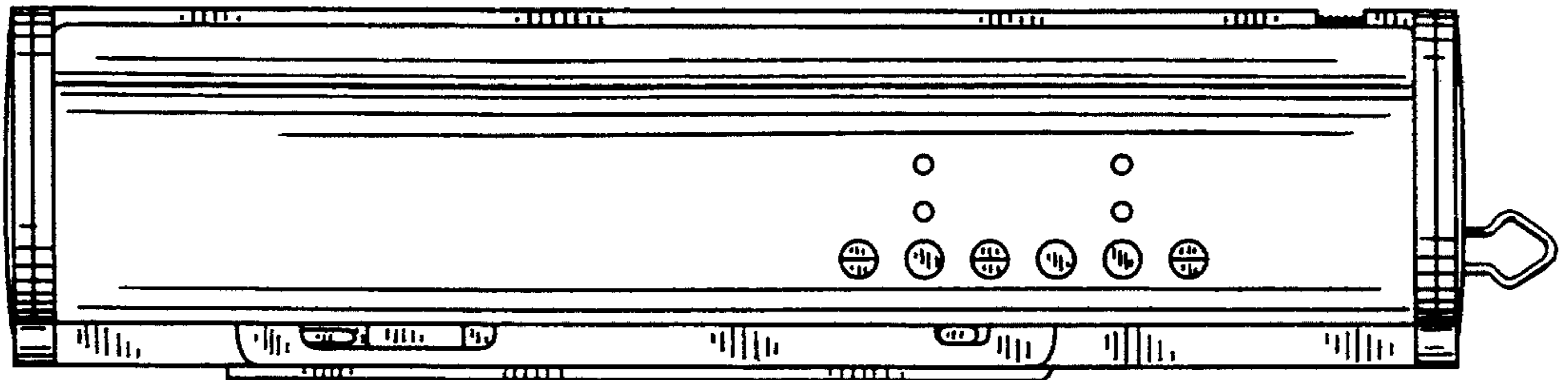

FIG. 8

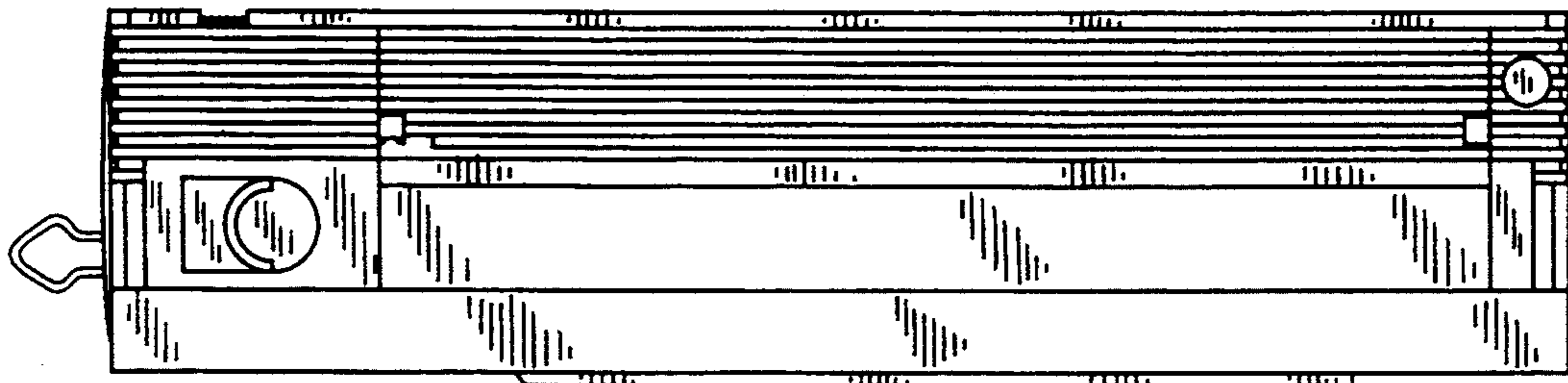

FIG. 9

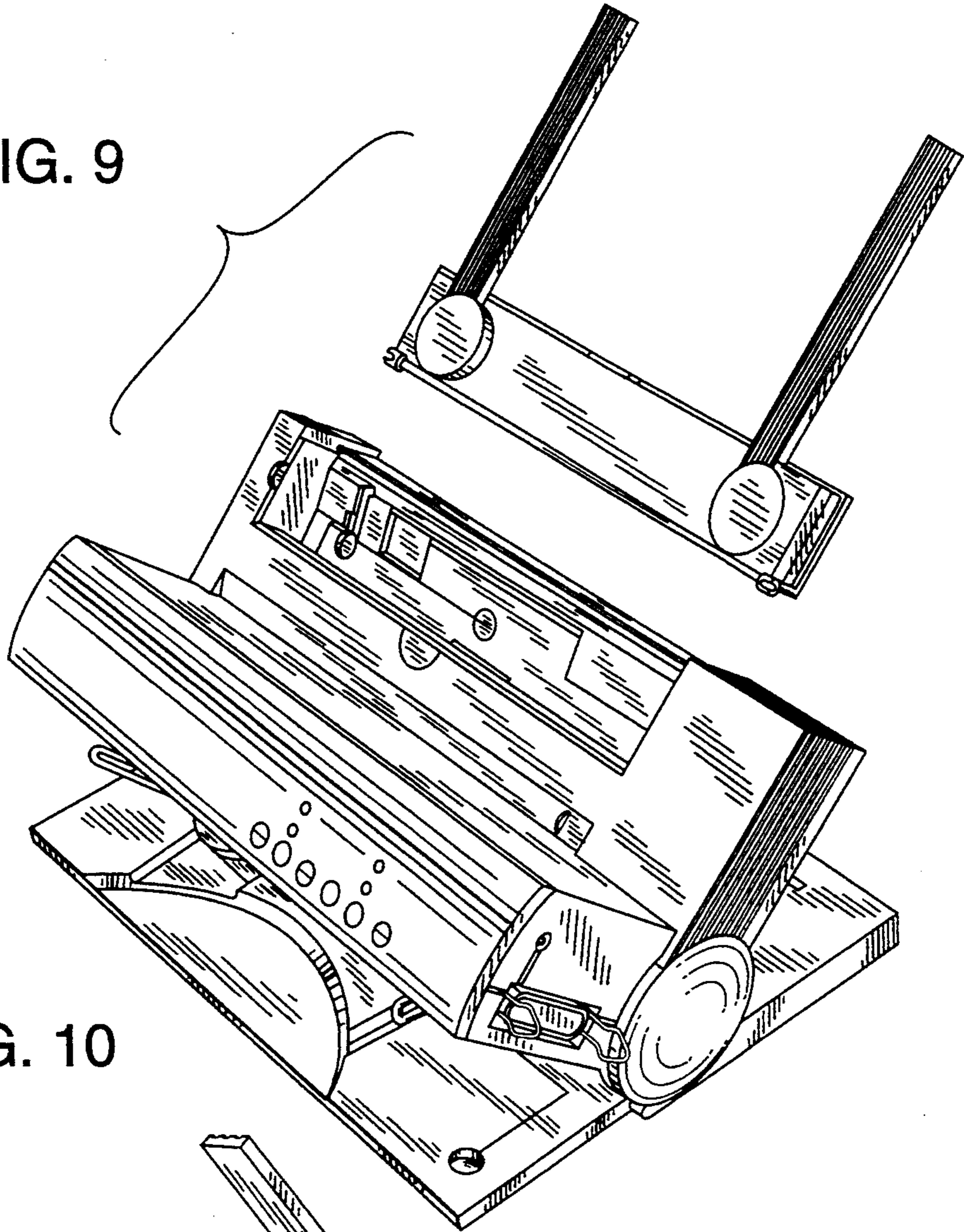

FIG. 10

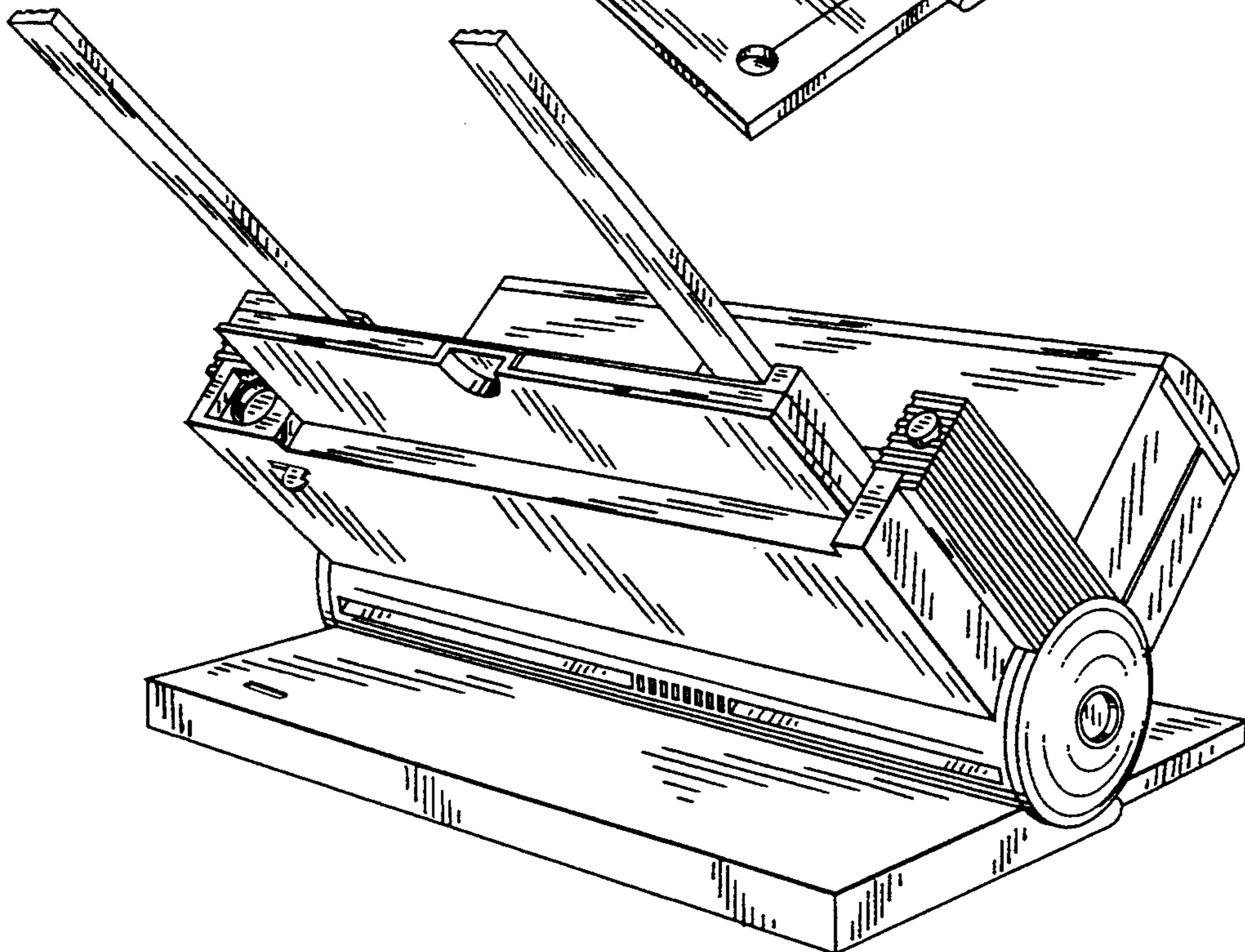

FIG. 11

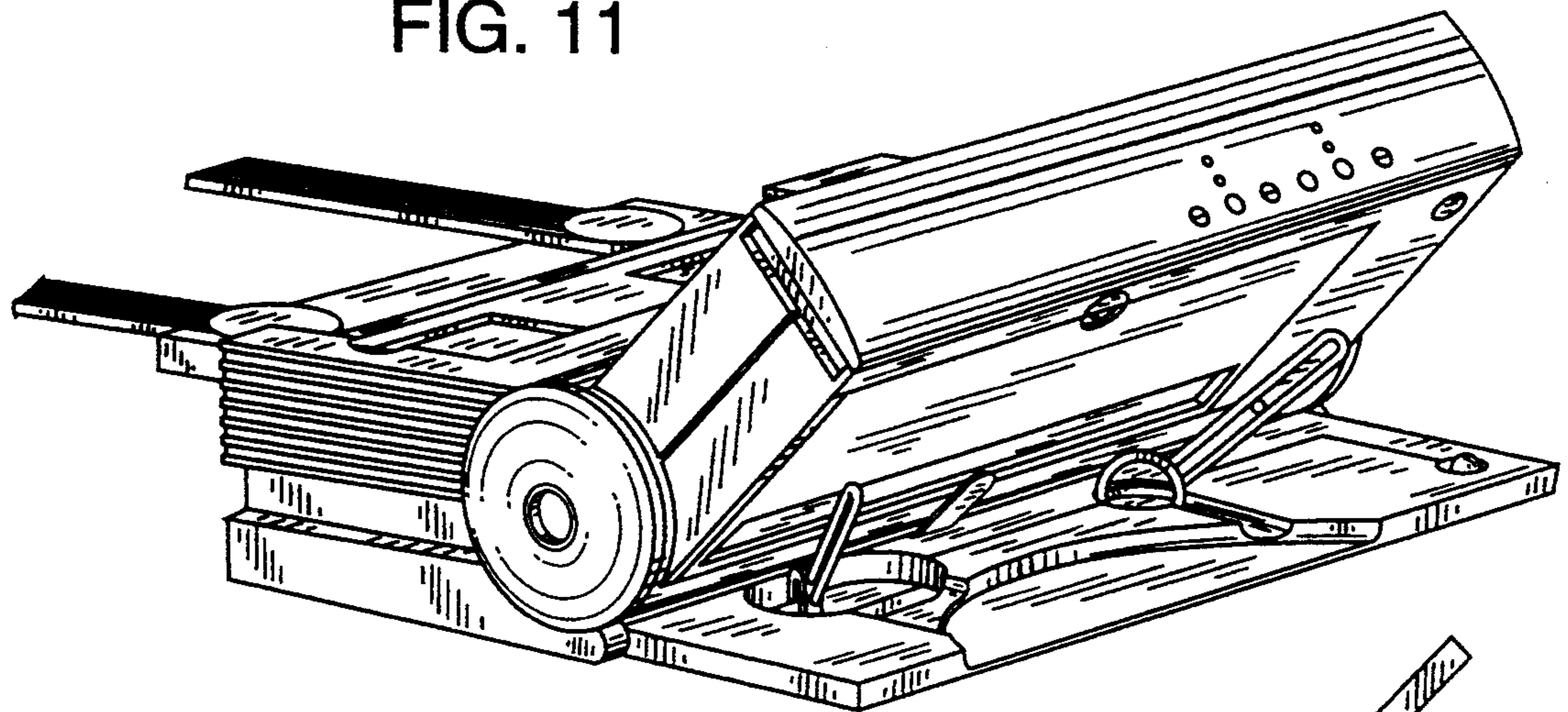
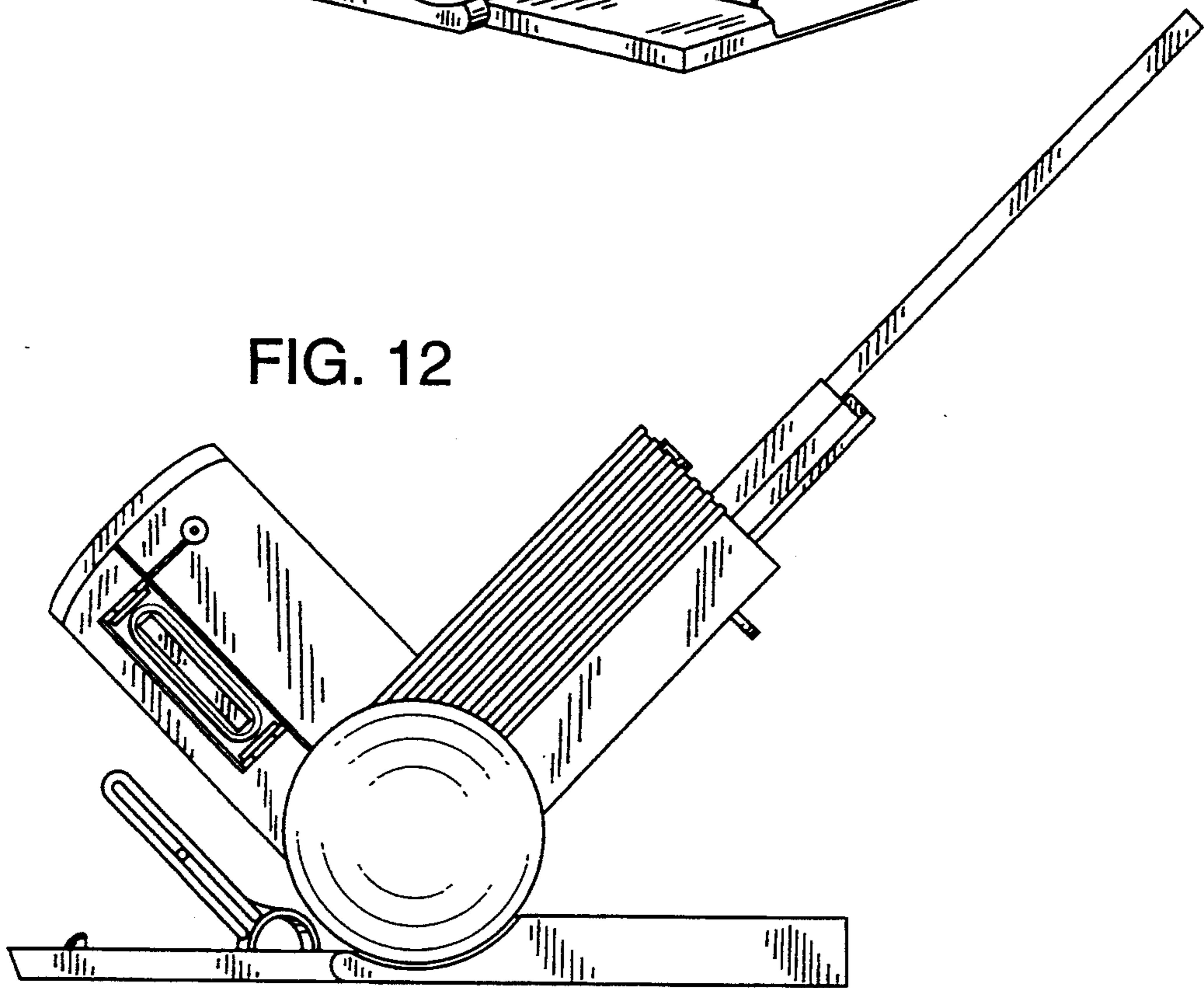

FIG. 12



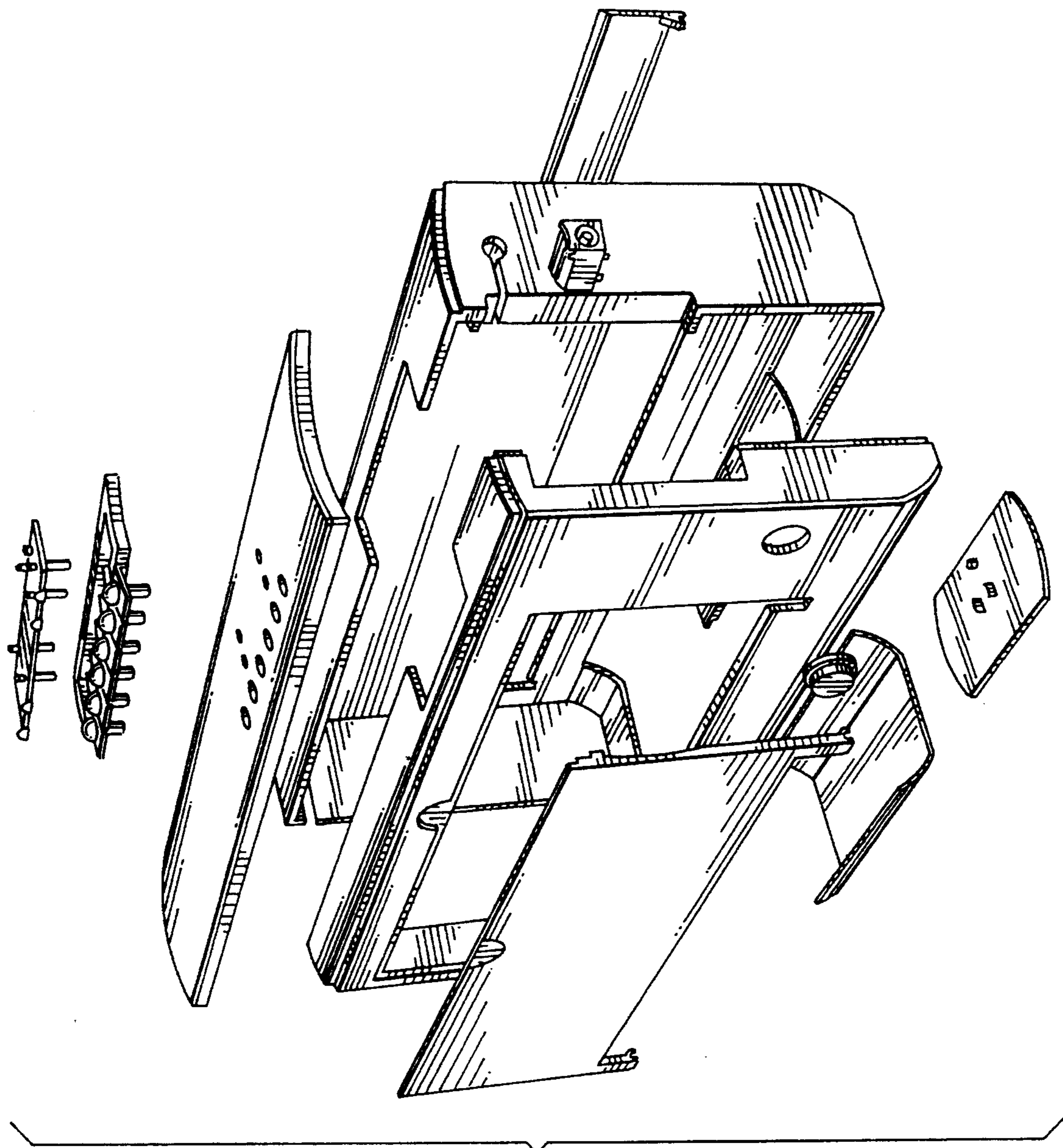

Fig. 13

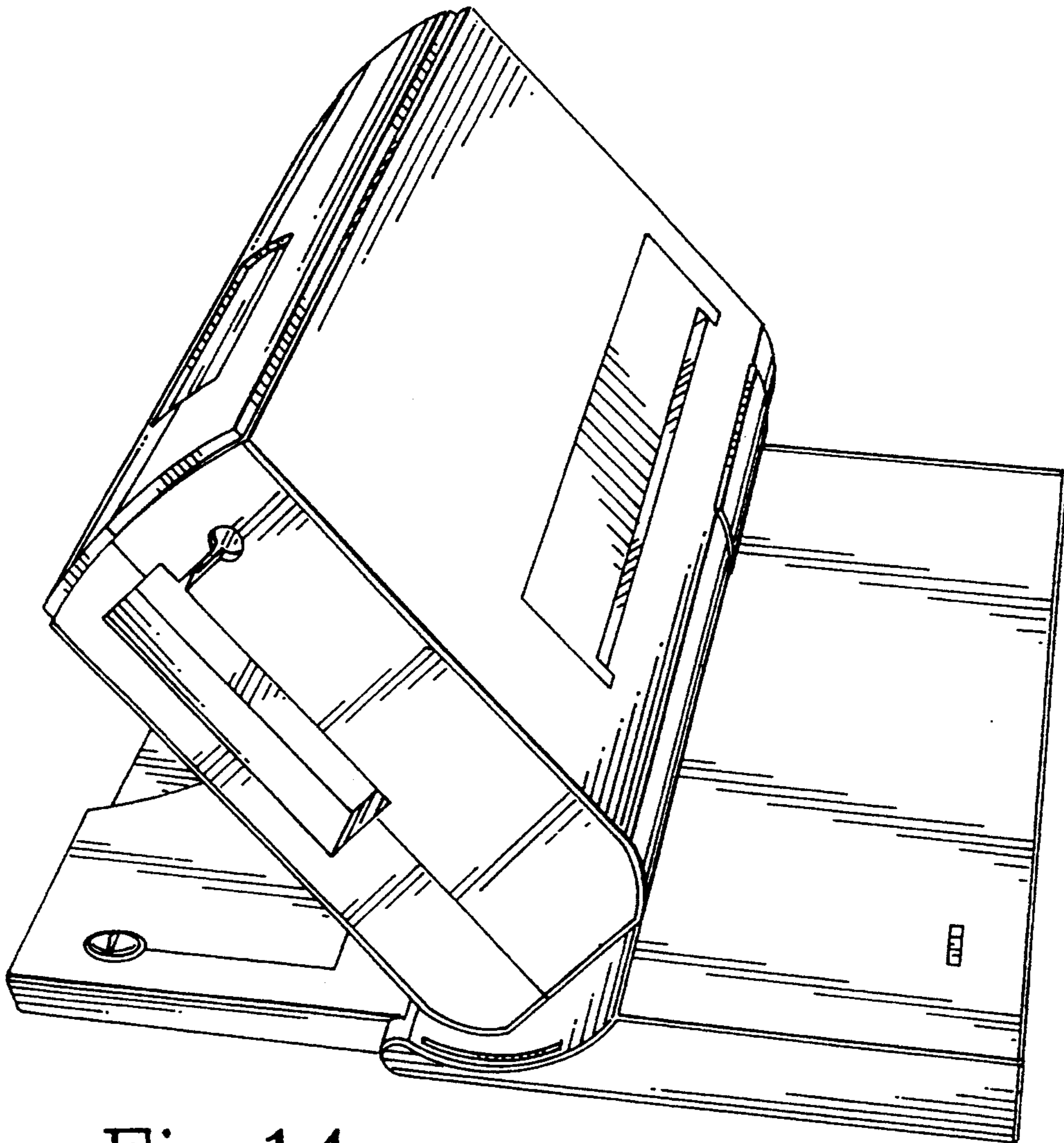

Fig. 14



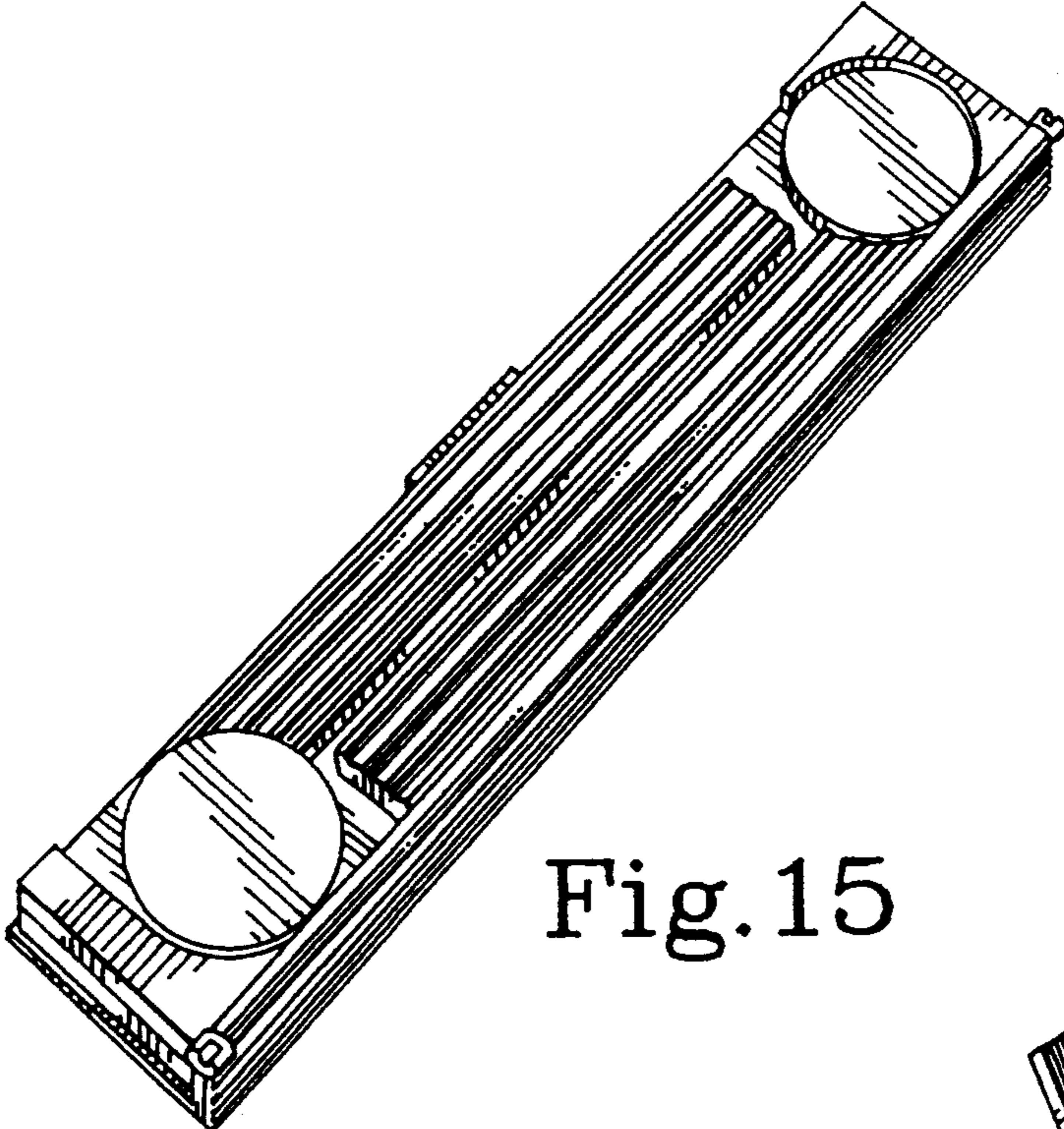

Fig. 15

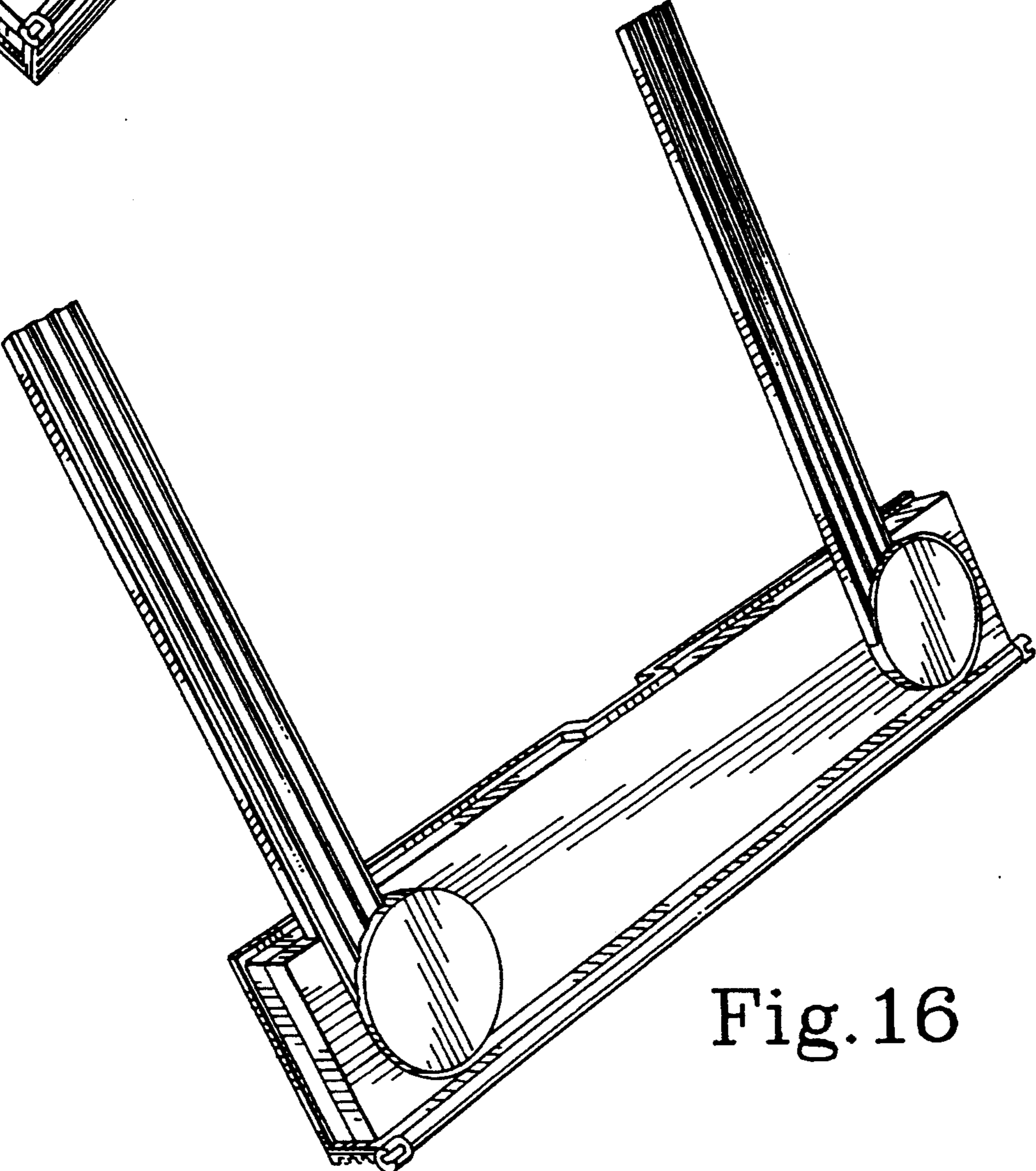

Fig. 16

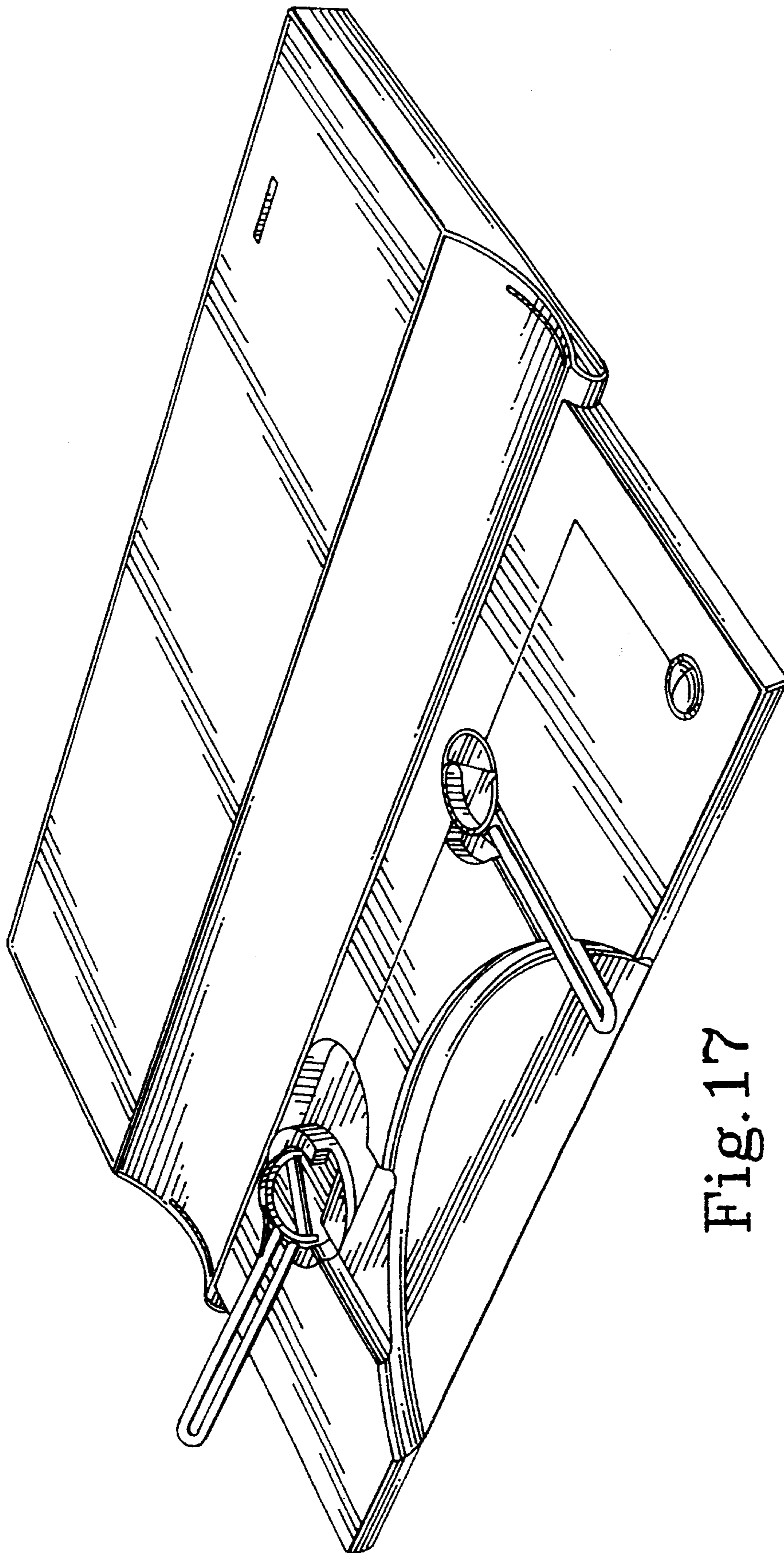

Fig. 17