



US00D351822S

United States Patent [19]

[11] Patent Number: **Des. 351,822**

Simonov et al.

[45] Date of Patent: **** Oct. 25, 1994**

[54] TWO-SEATED SPORTS PLANE

[76] Inventors: **Mikhail P. Simonov**, 125565 Moskva, Konokovsky proezd, 8-2-280, U.S.S.R.; **Boris V. Rakitin**, 113648 Moskva, Severnoe Chertanovo, 6-607-379, U.S.S.R.; **Leonid G. Chernov**, 129075 Moskva, ul., Argunovskaya 16-199, U.S.S.R.

[**] Term: **14 Years**

[21] Appl. No.: **943,452**

[22] Filed: **Sep. 10, 1992**

[30] Foreign Application Priority Data

Apr. 30, 1992 [SU] U.S.S.R. 63120
[52] U.S. Cl. **D12/344; D12/319**
[58] Field of Search 244/45 R, 45 A, 29;
D12/319, 344, 337, 335, 338

[56] References Cited

U.S. PATENT DOCUMENTS

D. 337,095 7/1993 Stmonov et al. D12/337

Primary Examiner—Kay H. Chin
Attorney, Agent, or Firm—Ladas & Parry

[57] CLAIM

The ornamental design for two-seated sports plane, as shown and described.

DESCRIPTION

FIG. 1 is a front top right side perspective view of the two-seated sports plane showing our new design; FIG. 2 is a right side elevational view thereof; FIG. 3 is a left side elevational view thereof; FIG. 4 is a front view thereof; FIG. 5 is a top view thereof; FIG. 6 is a rear view thereof; and, FIG. 7 is a bottom view thereof.

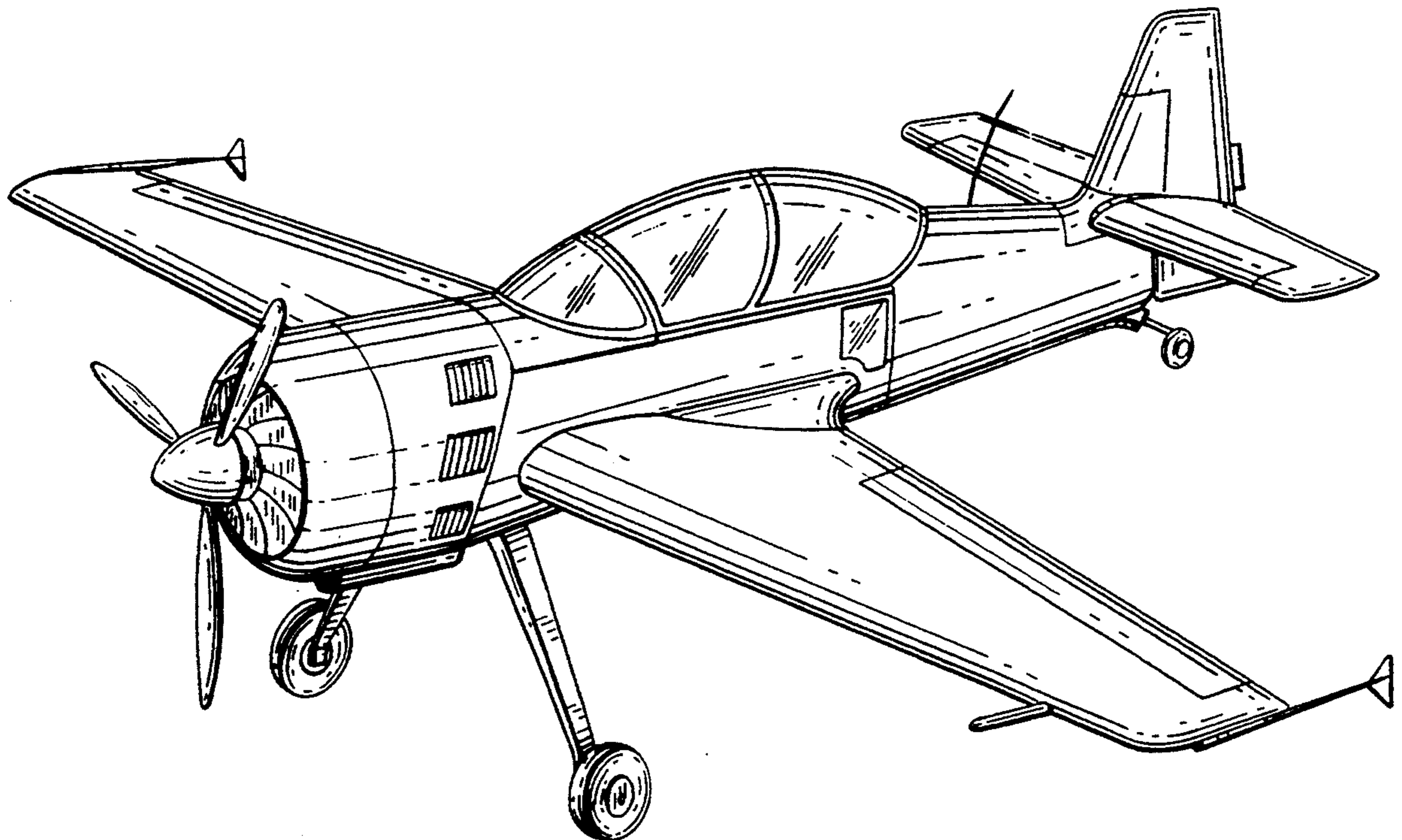

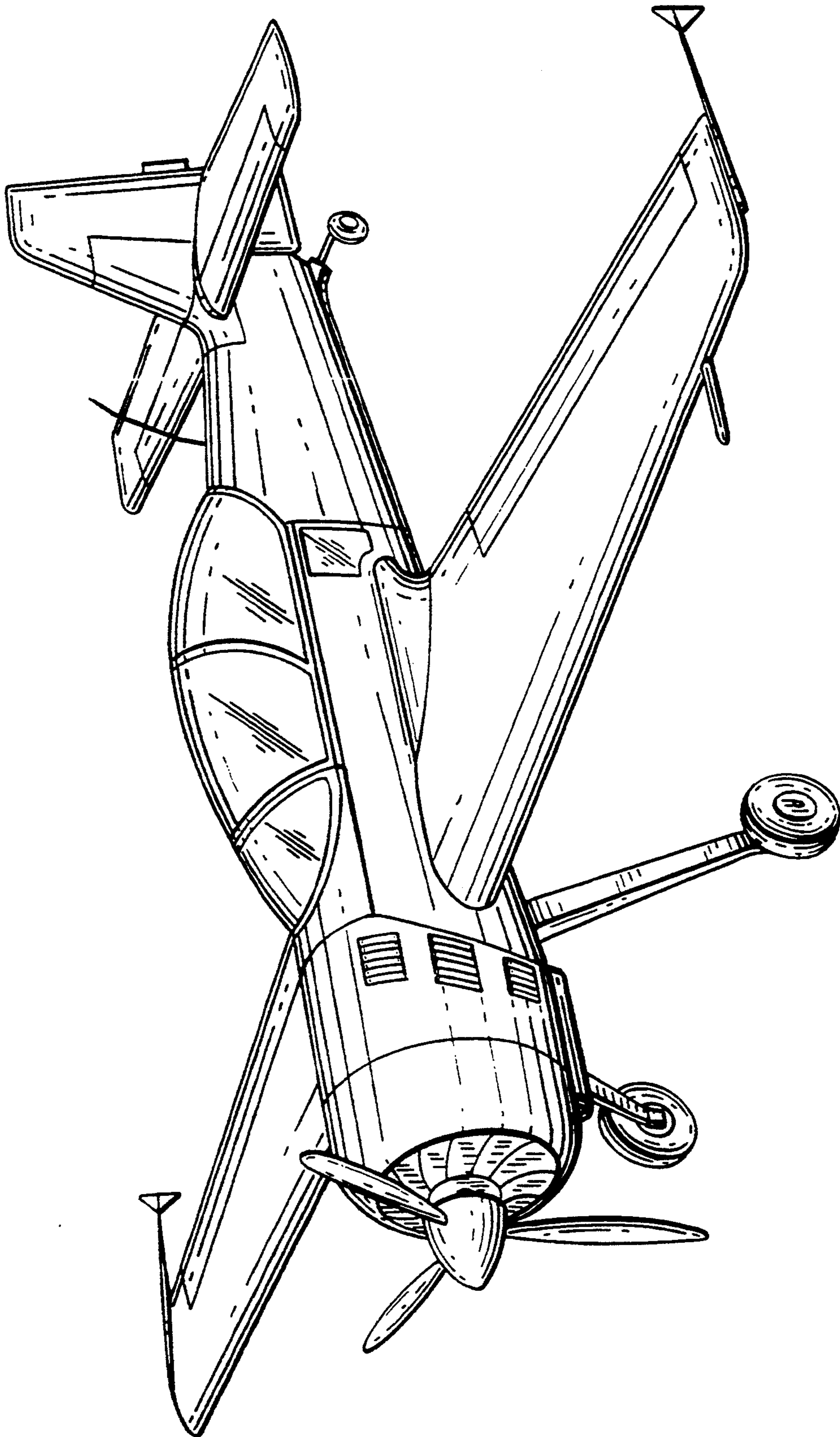

FIG. 1

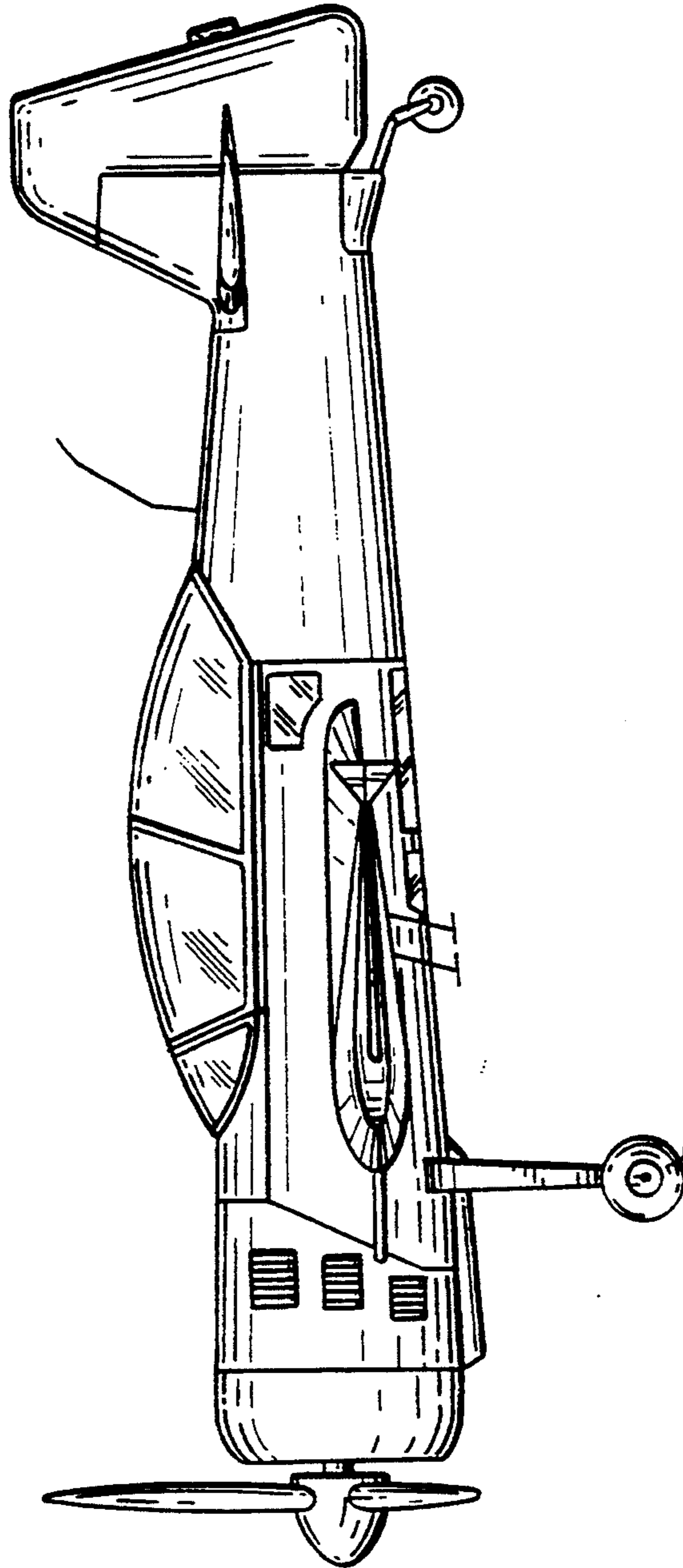

FIG. 2

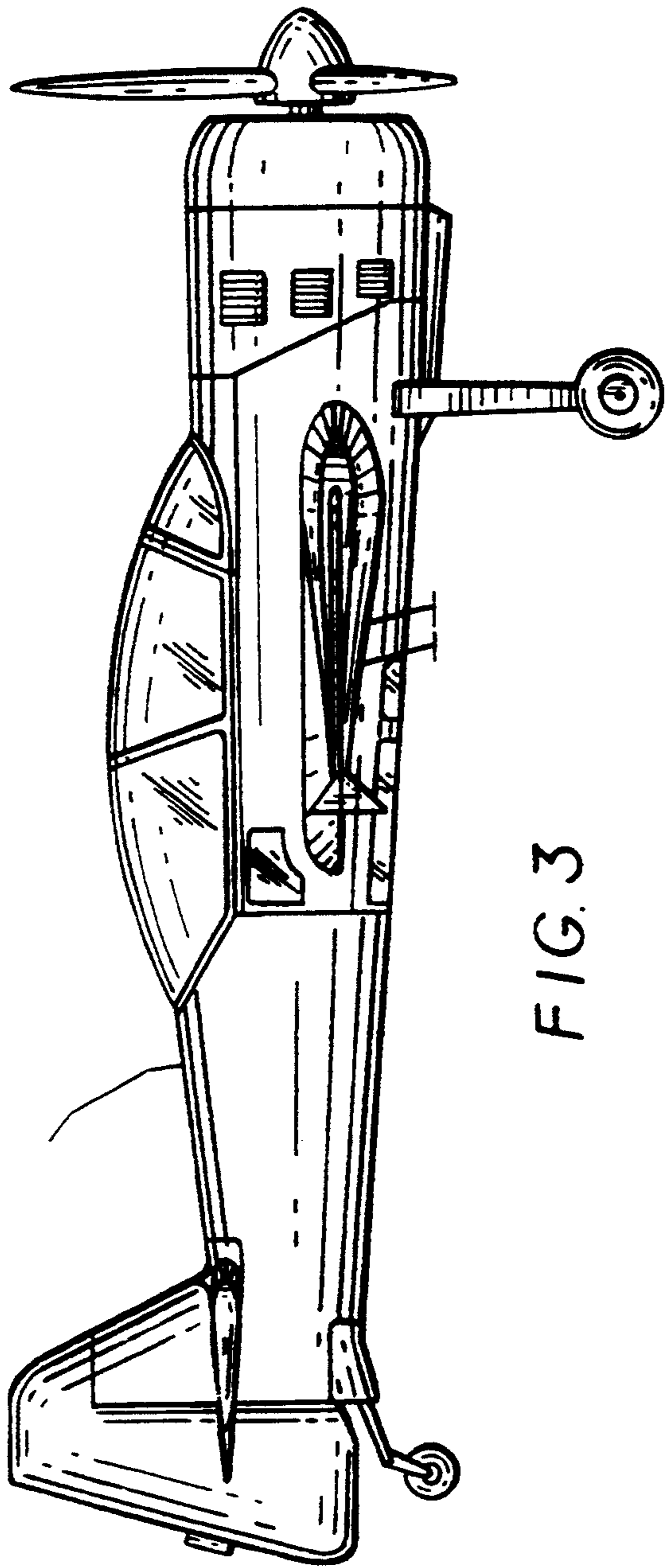

FIG. 3

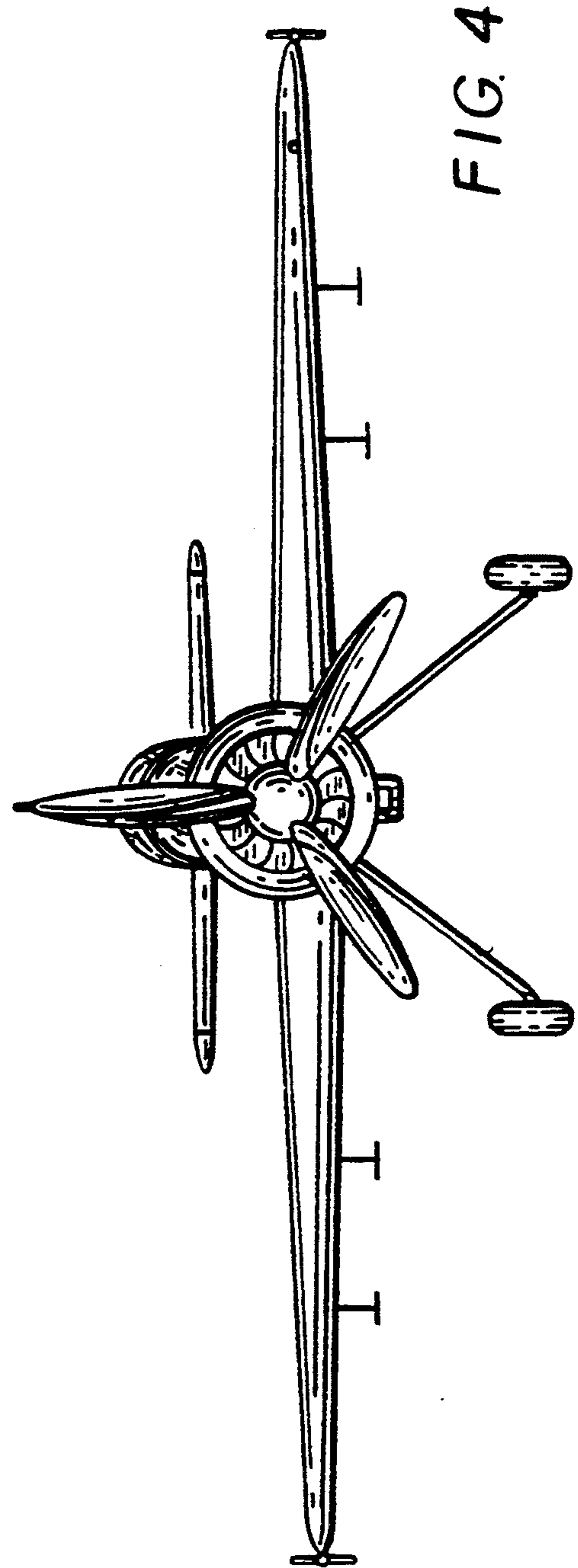

FIG. 4

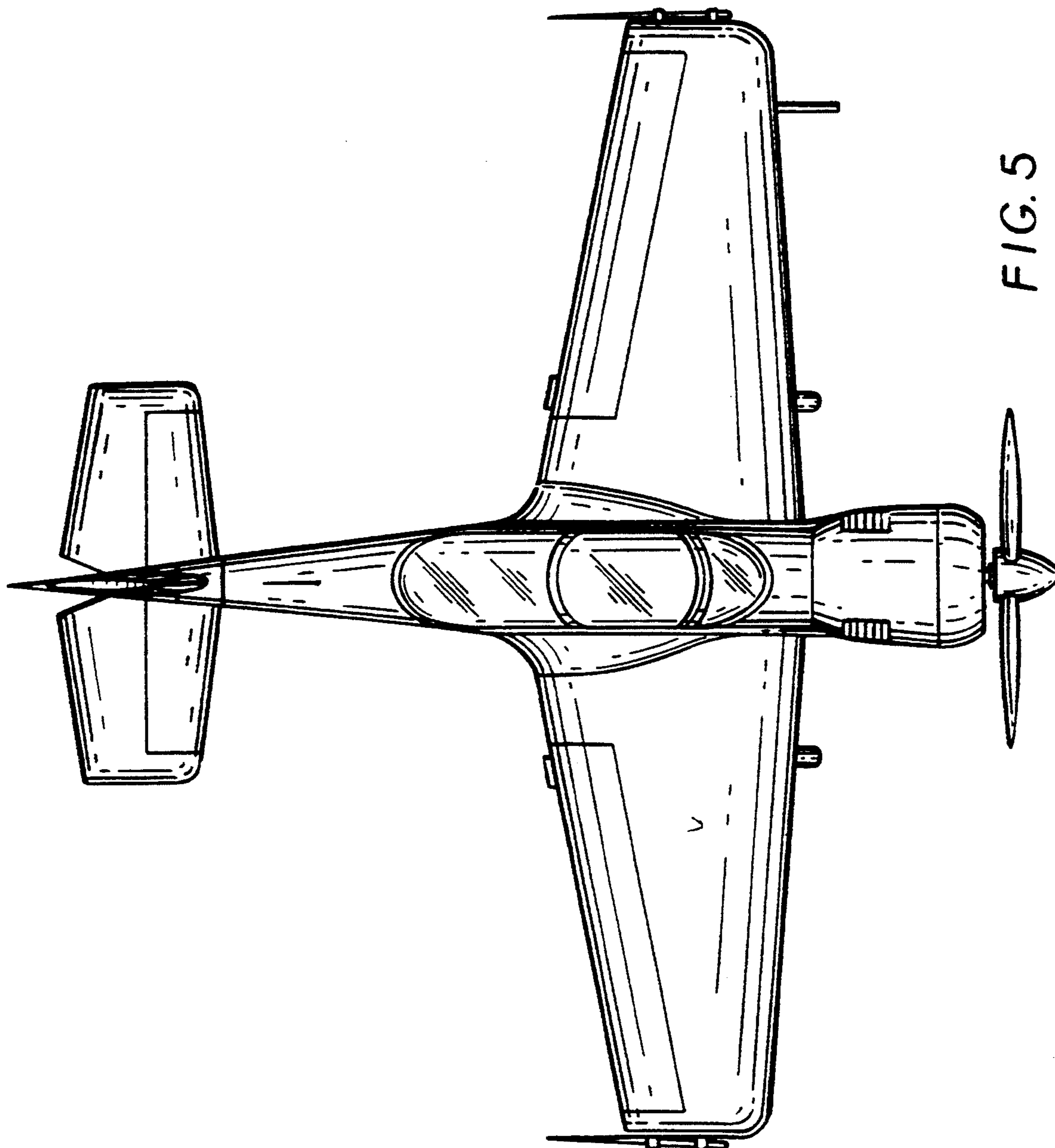

FIG. 5

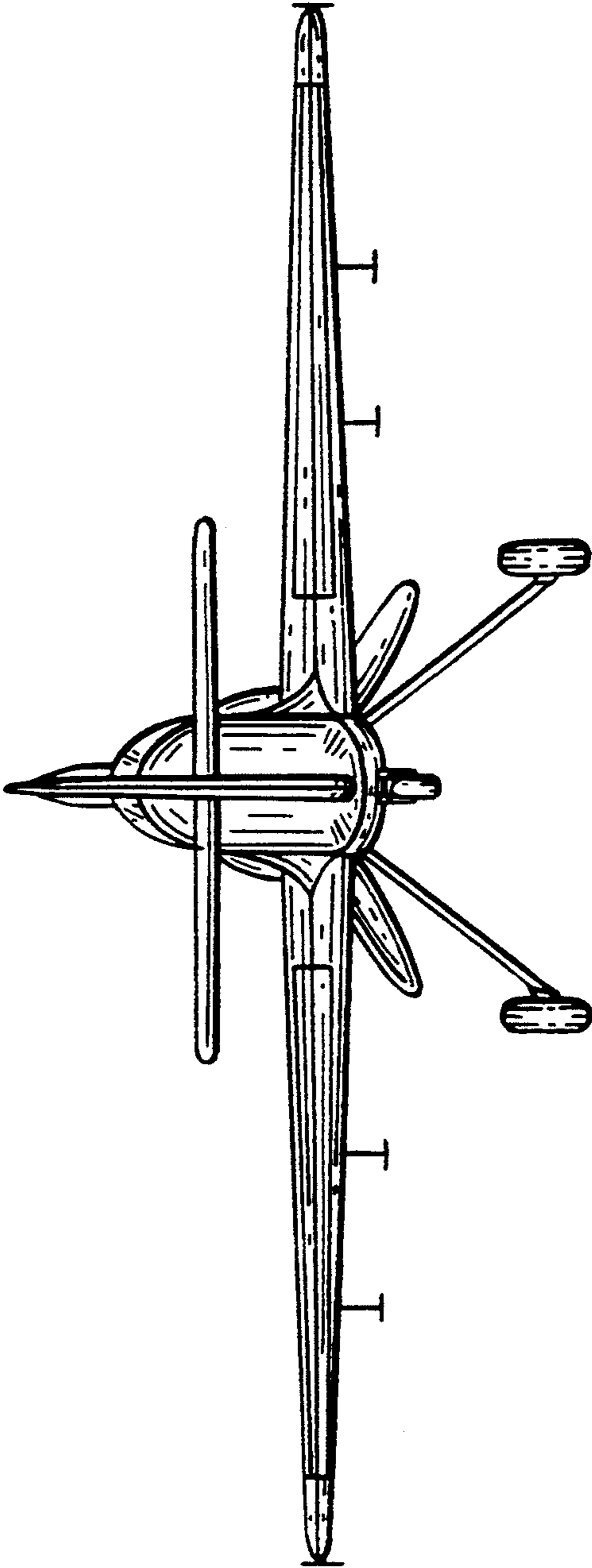

FIG. 6

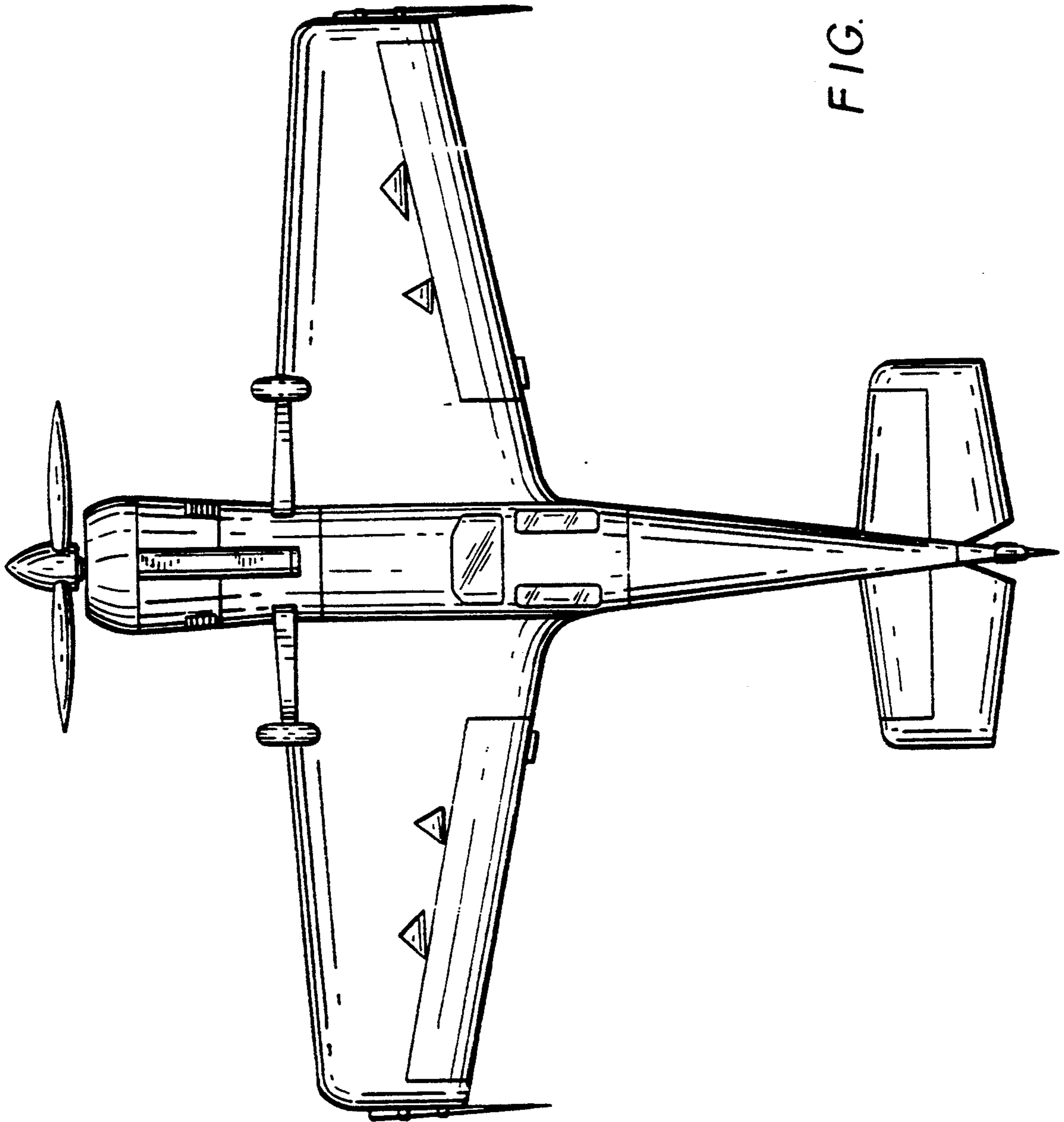

FIG. 7