



US00D351816S

# United States Patent [19]

[11] Patent Number: **Des. 351,816**

Lewellen et al.

[45] Date of Patent: **\*\* Oct. 25, 1994**

[54] **TRUCK BODY REAR END UNIT**

4,126,349 11/1978 Nelson et al. .... 296/37.6  
4,685,695 8/1987 LeVee ..... 296/24.1

[75] Inventors: **Richard Lewellen; George Kalis, Jr.; Robert M. Lapsley**, all of Wooster, Ohio

*Primary Examiner*—James M. Gandy  
*Attorney, Agent, or Firm*—Watts, Hoffmann, Fisher & Heinke

[73] Assignee: **Stahl/Scott Fetzer Company**, Wooster, Ohio

[57] **CLAIM**

[\*\*] Term: **14 Years**

The ornamental design for a truck body rear end unit, as shown and described.

[21] Appl. No.: **3,189**

**DESCRIPTION**

[22] Filed: **Jan. 4, 1993**

[52] U.S. Cl. .... **D12/98**

[58] Field of Search ..... 296/183, 50, 55, 57, 296/24.1, 37.6; D12/98, 14, 196, 169

FIG. 1 is a perspective view of a truck body rear end unit showing our new design;

FIG. 2 is a left-side elevational view thereof, the right-side elevational view being a mirror image thereof;

FIG. 3 is a rear elevational view thereof;

FIG. 4 is a front elevational view thereof;

FIG. 5 is an enlarged top plan view thereof; and,

FIG. 6 is an enlarged bottom plan view thereof.

The broken line showing of a pickup truck in FIGS. 1, 2, 3, 5 and 6 of the drawings is for illustrative purposes only and forms no part of the claimed design.

[56] **References Cited**

**U.S. PATENT DOCUMENTS**

- D. 157,321 2/1950 Barden ..... D12/169
- D. 345,123 3/1994 Lewellen et al. .... D12/98
- D. 345,124 3/1994 Lewellen et al. .... D12/98
- 3,245,713 4/1966 Ogilvie ..... 296/24.1

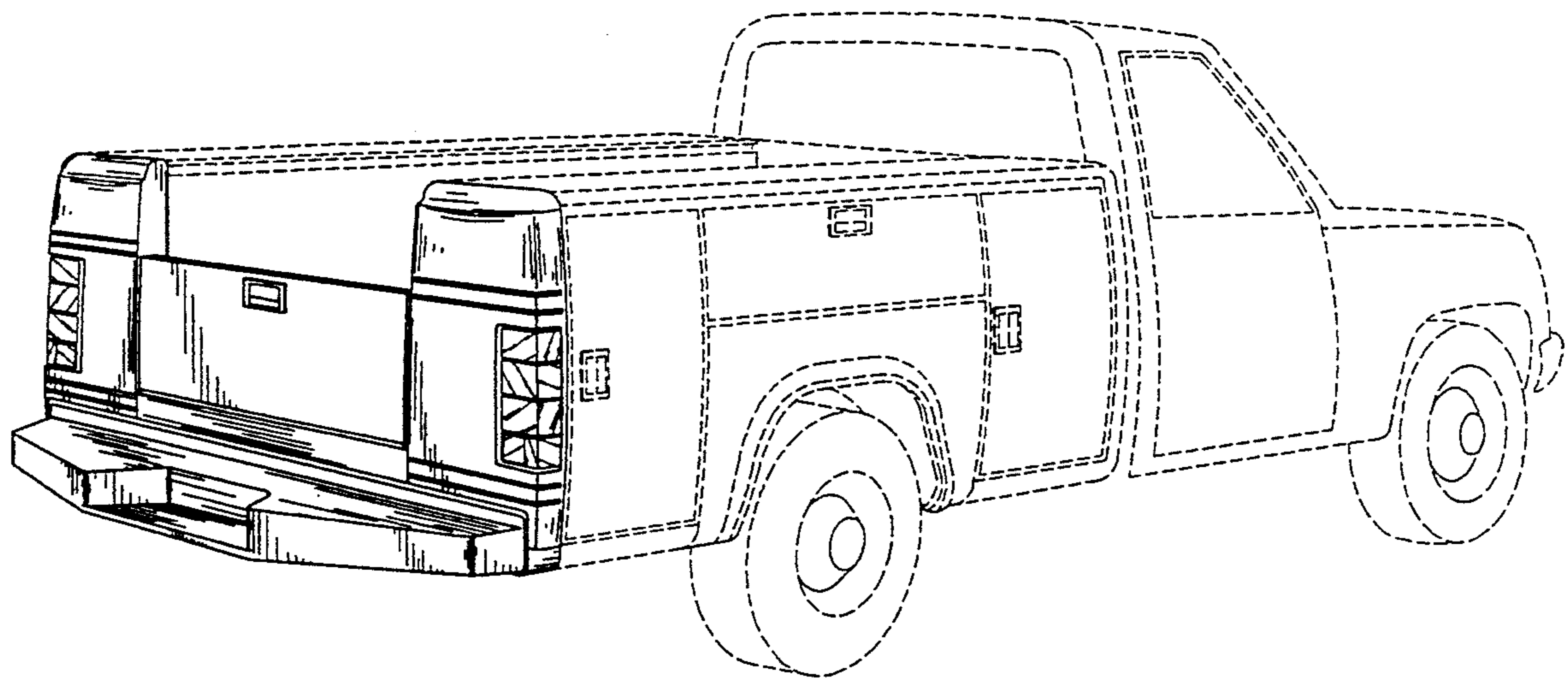

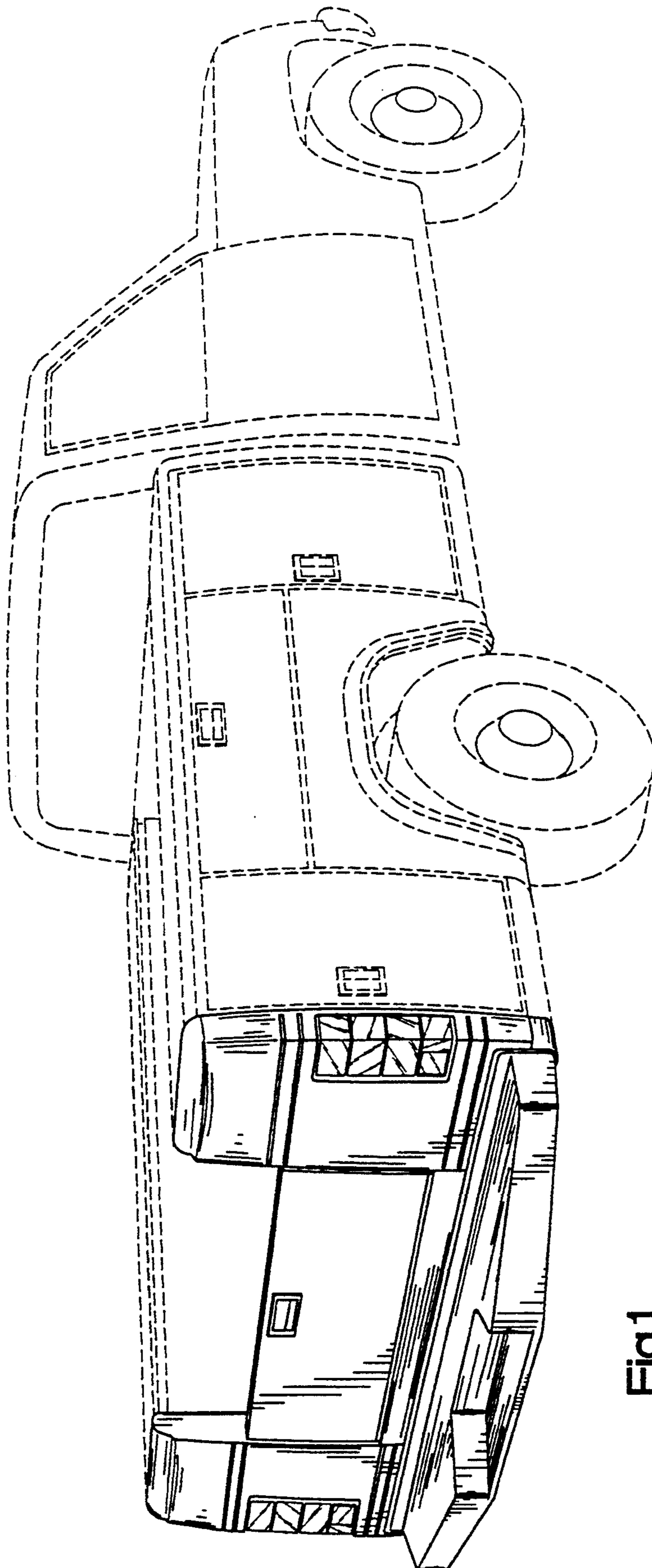

Fig.1

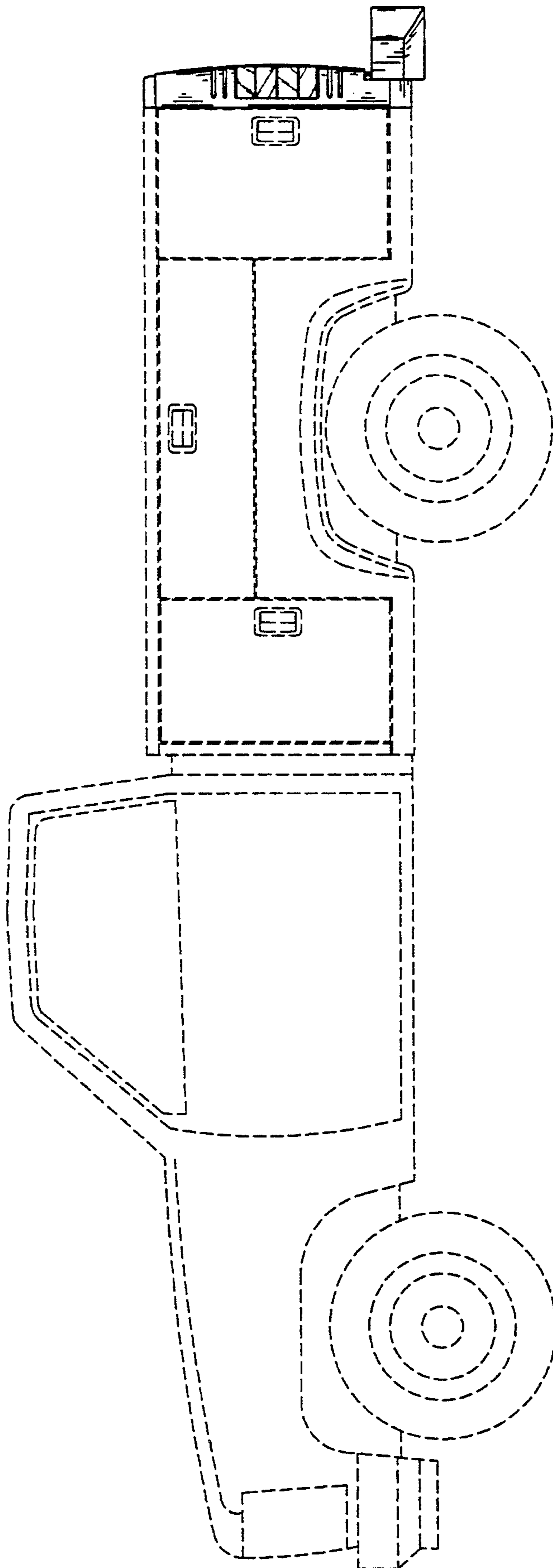

Fig.2

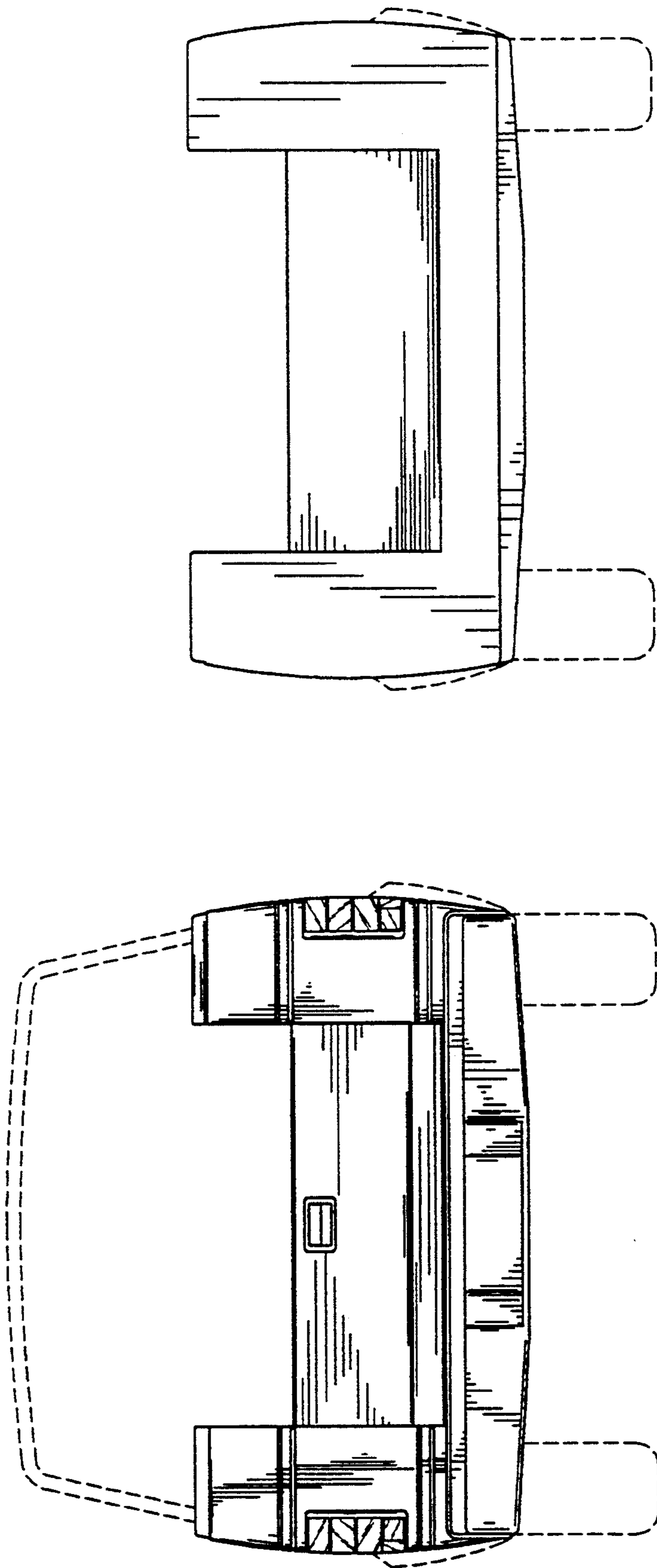

Fig.4

Fig.3

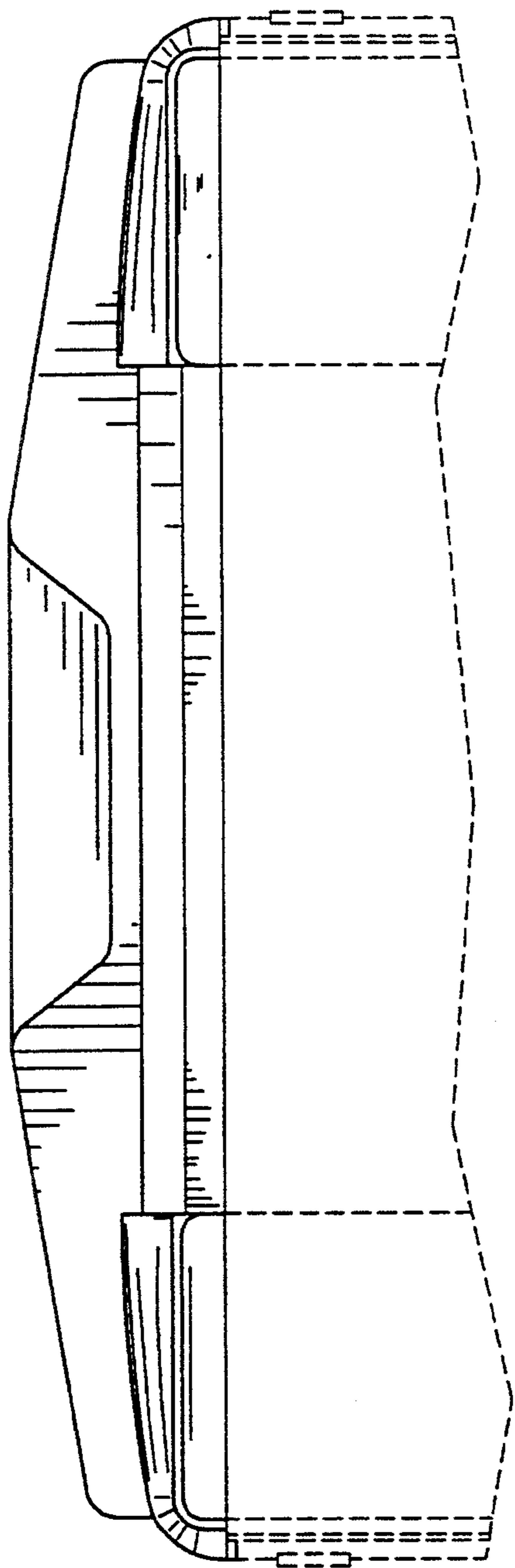

Fig.5

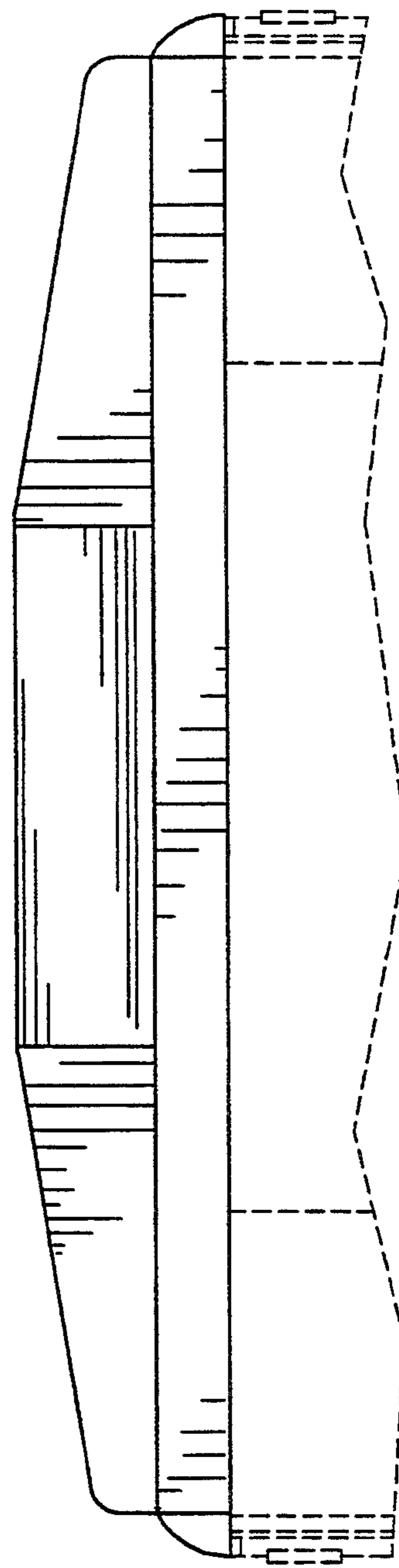

Fig.6