



US00D351710S

United States Patent [19]

Richardson

[11] Patent Number: **Des. 351,710**

[45] Date of Patent: **** Oct. 18, 1994**

[54] **VEHICLE RAMP**

[75] Inventor: **Robert K. Richardson**, Minerva, Ohio

[73] Assignee: **Ganeaux Industries, Inc.**, Salem, Ohio

[**] Term: **14 Years**

[21] Appl. No.: **10,795**

[22] Filed: **Jul. 19, 1993**

[52] U.S. Cl. **D34/32**

[58] Field of Search 14/69.5, 71.1, 71.3, 14/71.5; 105/433, 436; 414/522, 537, 538, 541, 549, 558, 779, 921; 254/88; D34/28, 29, 32

[56] **References Cited**

U.S. PATENT DOCUMENTS

D. 228,301	9/1973	Lundman	D41/1 C
D. 232,020	7/1974	Borsuk	D12/53
D. 237,162	10/1975	Miller	D12/53
D. 239,610	4/1976	Miller	D12/53
D. 313,102	12/1990	Cano	D34/32
3,730,361	5/1976	Haynes	474/537

3,847,376 11/1974 Binding 254/88

FOREIGN PATENT DOCUMENTS

162885 5/1955 Australia 254/88

Primary Examiner—Wallace R. Burke
Assistant Examiner—Robin V. Taylor
Attorney, Agent, or Firm—Michael Sand Co.

[57] **CLAIM**

The ornamental design for a vehicle ramp, as shown and described.

DESCRIPTION

FIG. 1 is a side elevational of a vehicle ramp showing my new design, the opposite side view being a mirror image of that shown;
FIG. 2 is a top plan view thereof;
FIG. 3 is a bottom plan view thereof;
FIG. 4 is a rear elevational view thereof;
FIG. 5 is a front elevational view thereof;
FIG. 6 is a fragmentary top plan view thereof taken along the line 6—6 of FIG. 1; and,
FIG. 7 is a top perspective view thereof.

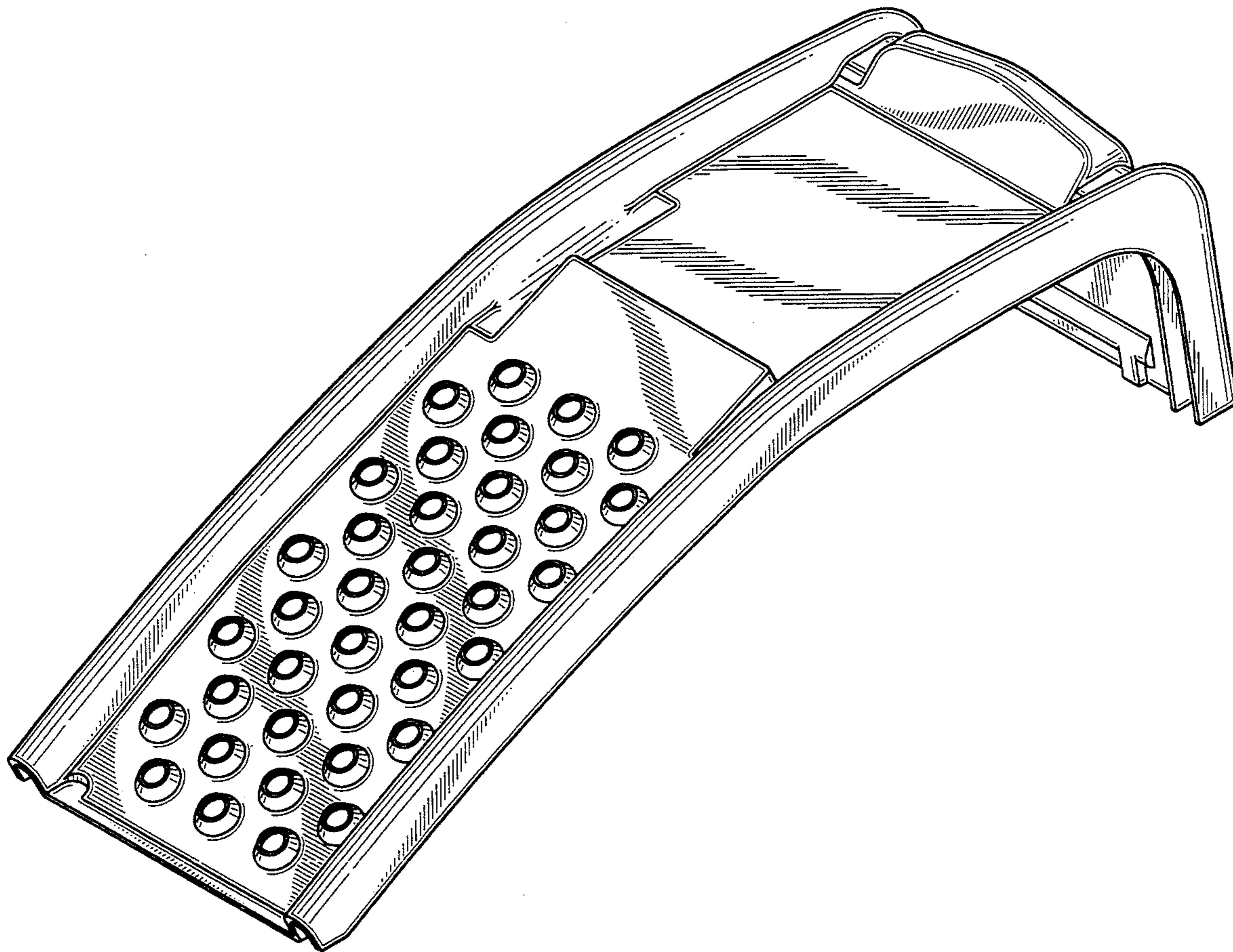

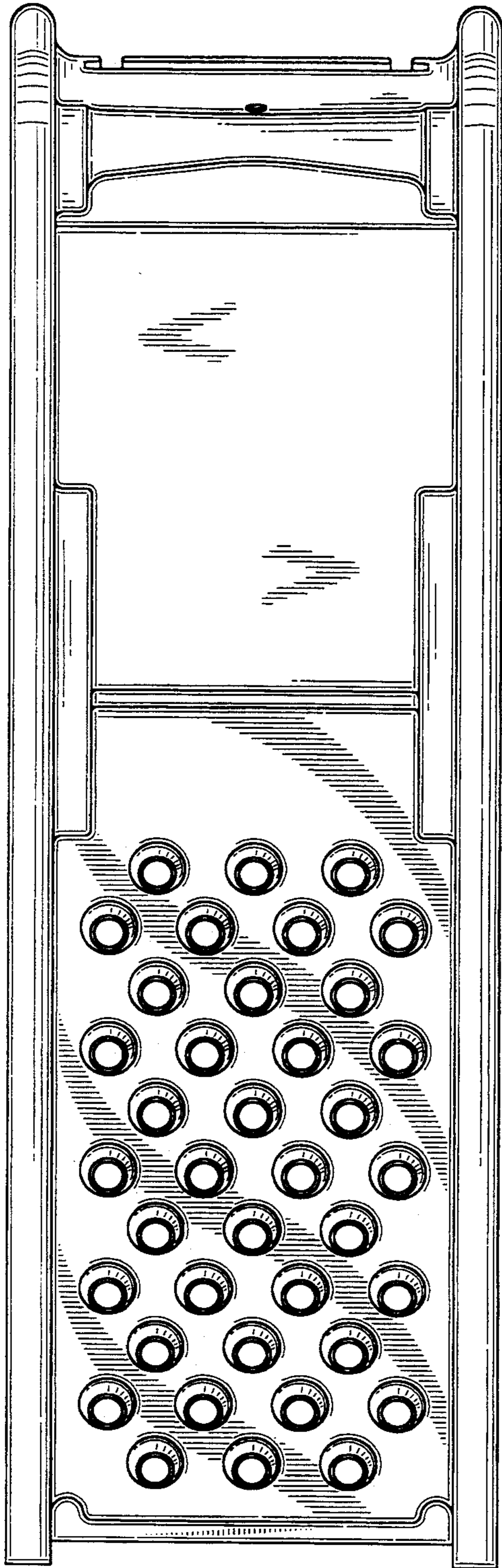

FIG-2

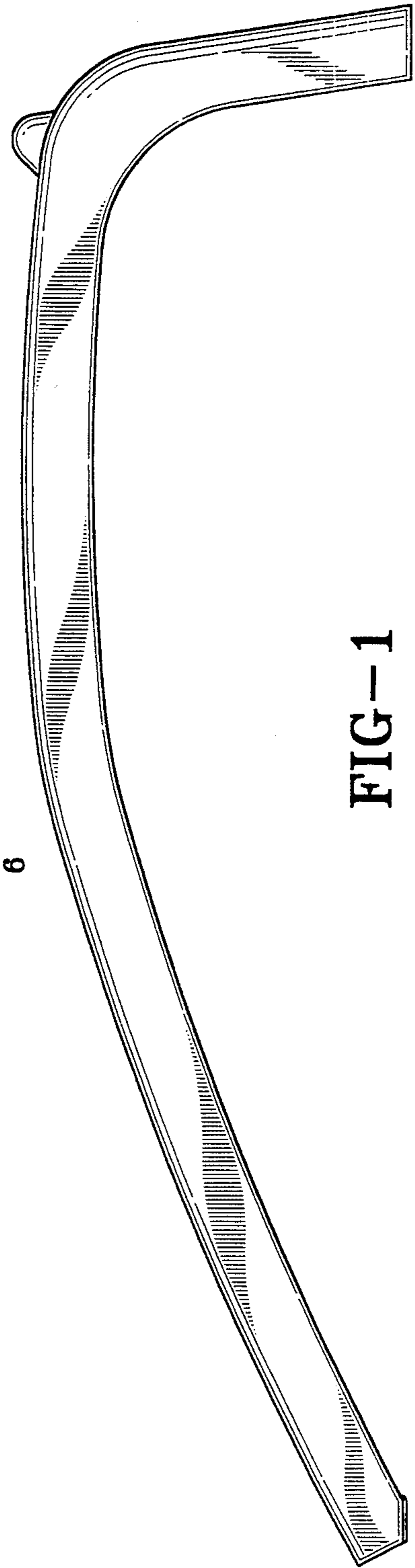

FIG-1



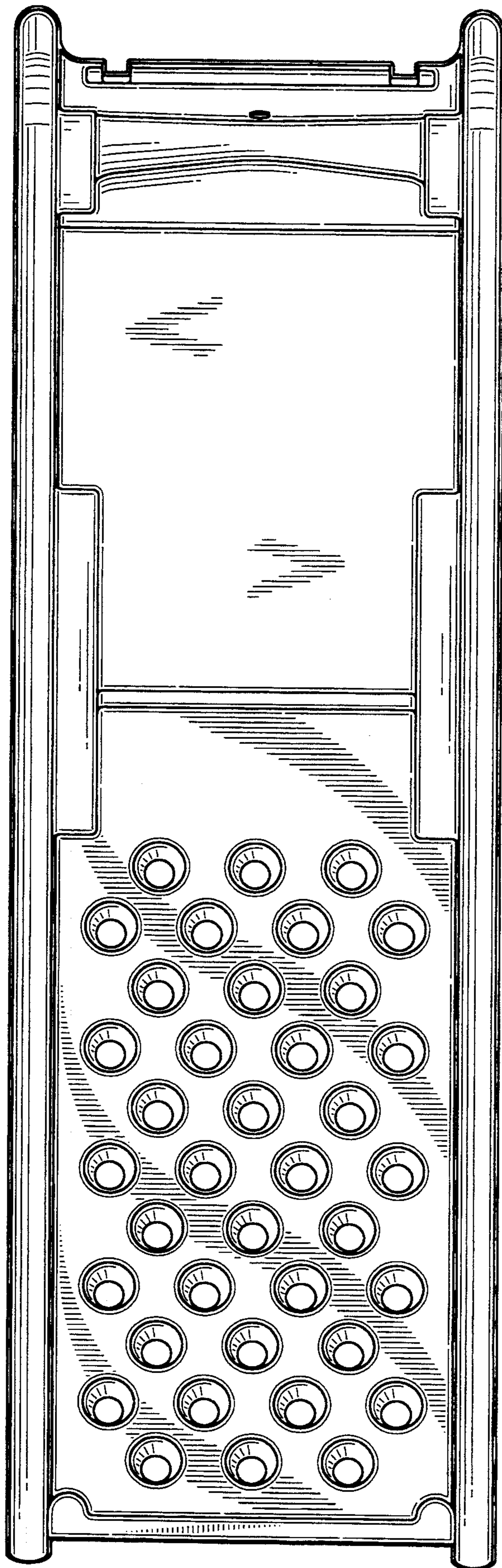

FIG-3

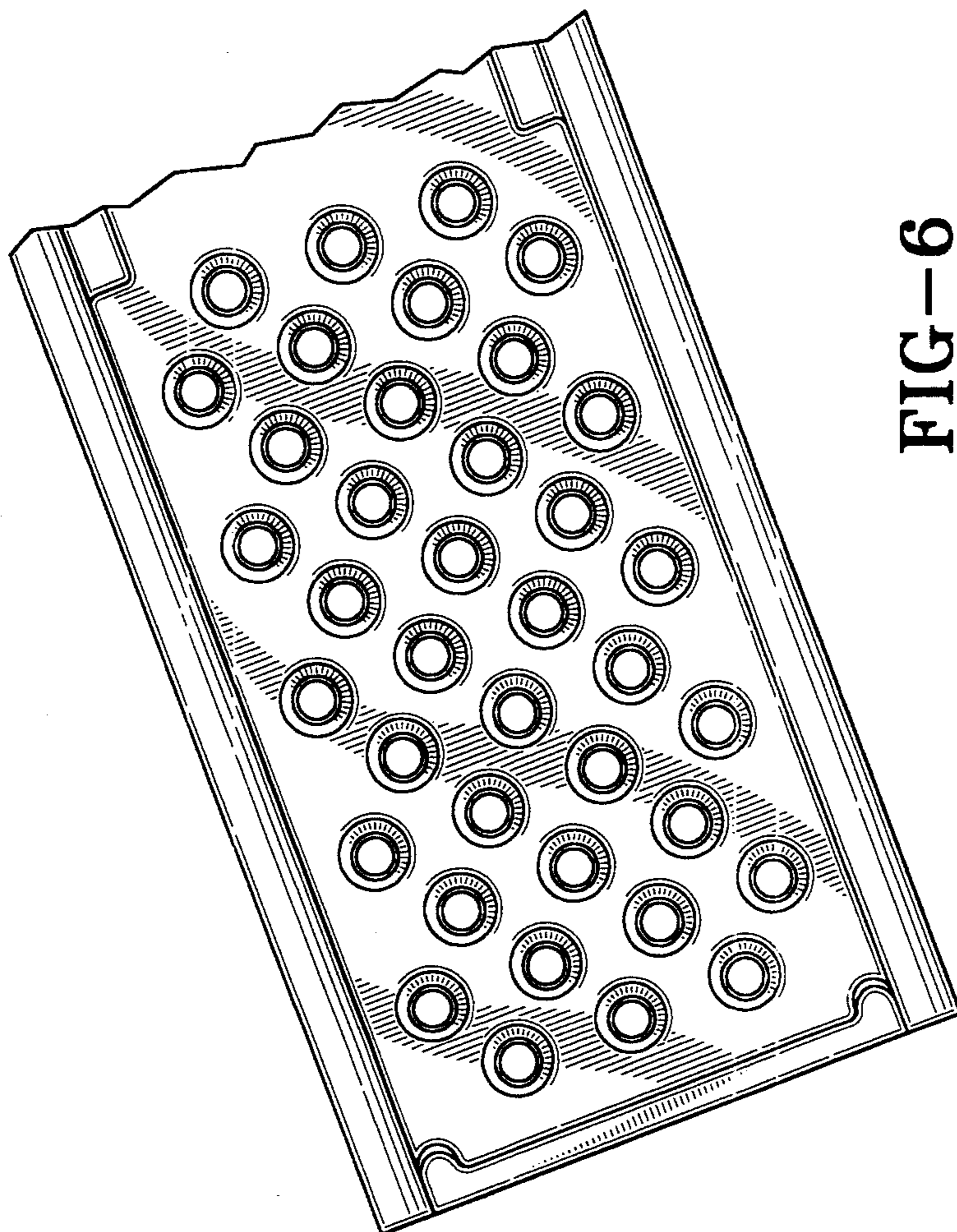

FIG-6

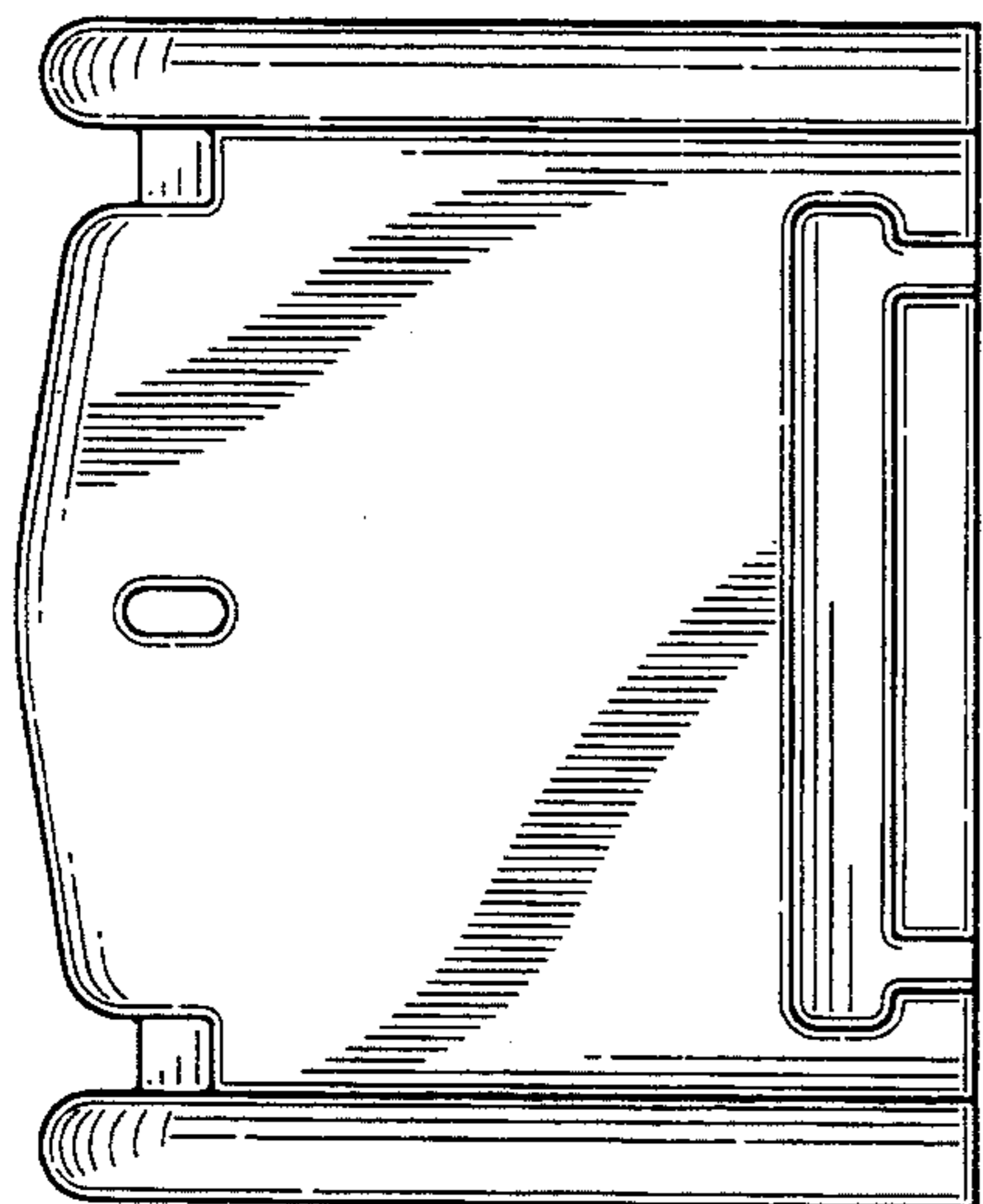

FIG-4

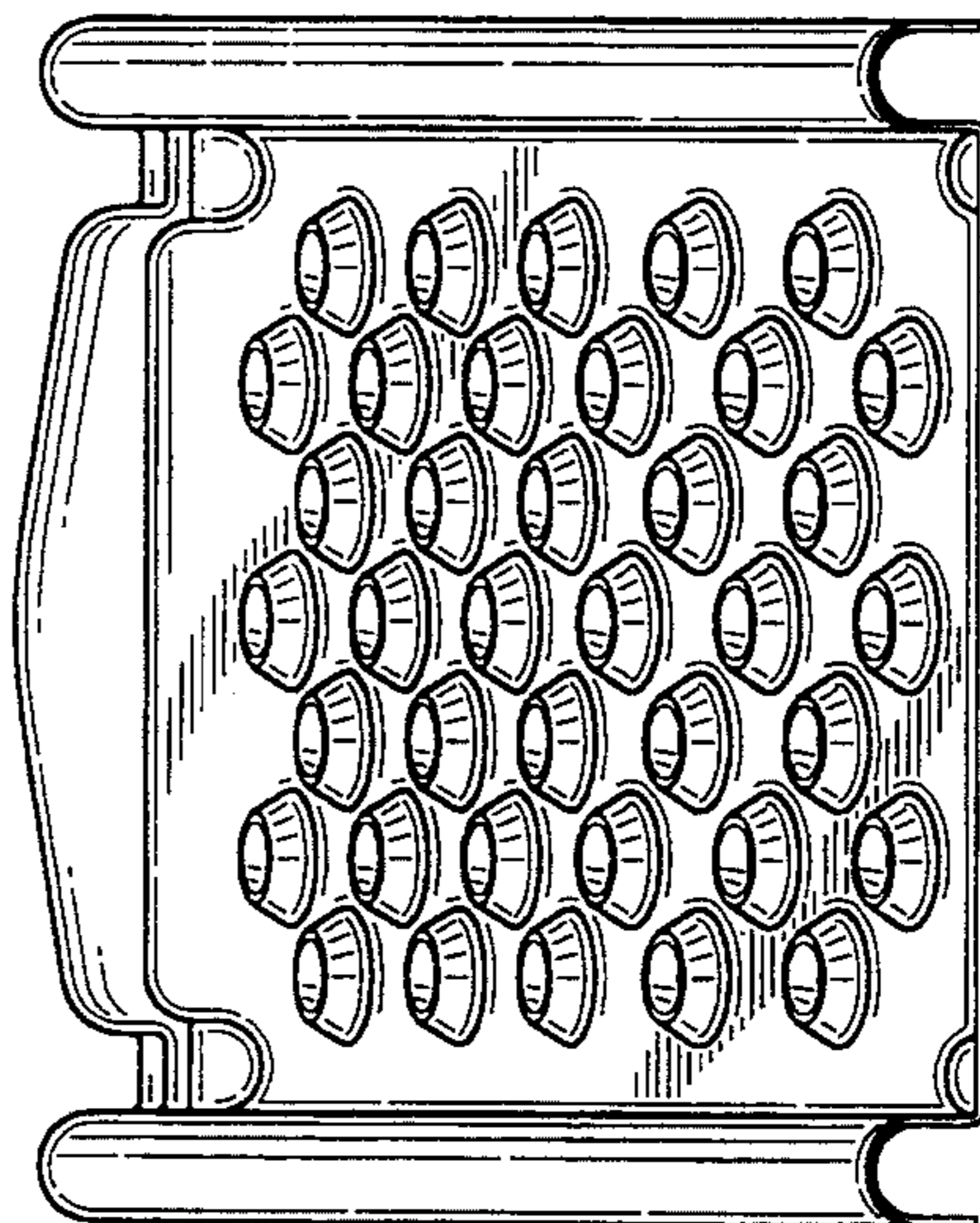

FIG-5

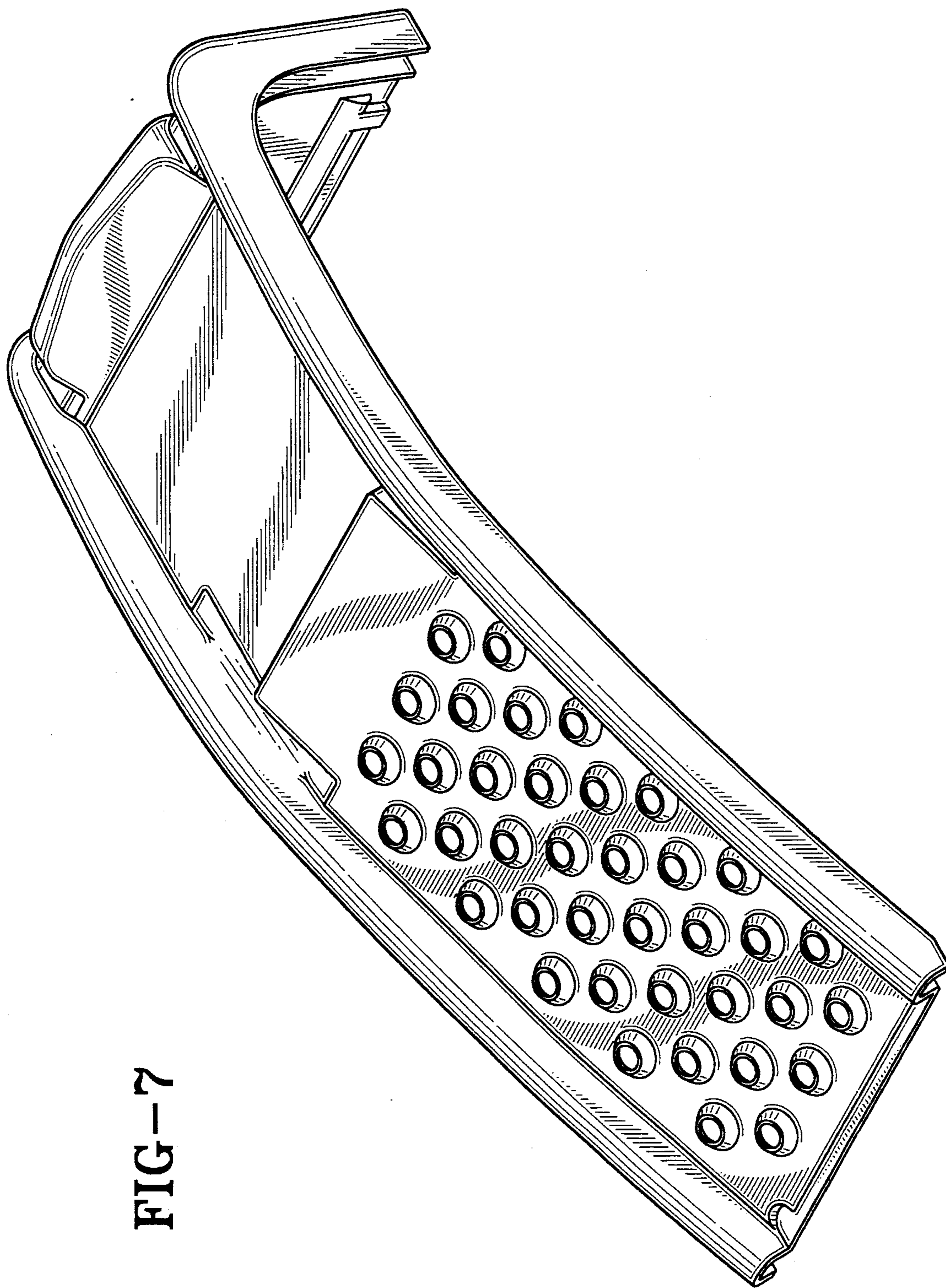

FIG-7