



US00D351667S

United States Patent [19]

[11] Patent Number: **Des. 351,667**

Bancroft

[45] Date of Patent: **** Oct. 18, 1994**

[54] RAIL ELEMENT

[76] Inventor: **Joseph C. Bancroft**, 102 Sweetwater Club Blvd., Longwood, Fla. 32750

[**] Term: **14 Years**

[21] Appl. No.: **11,378**

[22] Filed: **Aug. 2, 1993**

[52] U.S. Cl. **D25/124**

[58] Field of Search 49/504, 505, DIG. 2; 52/204.1, 204.5; D25/124, 52

[56] **References Cited**

U.S. PATENT DOCUMENTS

- D. 334,628 4/1993 Cole D25/124
- D. 335,931 5/1993 Cole D25/124
- 4,740,405 4/1988 Tanaka et al. 49/504

Primary Examiner—A. Hugo Word

Assistant Examiner—Doris Clark
Attorney, Agent, or Firm—Macdonald J. Wiggins

[57] **CLAIM**

The ornamental design for a rail element, as shown and described.

DESCRIPTION

FIG. 1 is a fragmentary top perspective view of the rail element showing my design;
 FIG. 2 is a top plan view thereof broken away to indicate indeterminate length;
 FIG. 3 is a bottom plan view thereof broken away to indicate indeterminate length;
 FIG. 4 is a front elevation view thereof in which the rear elevational view is a mirror image of the front view;
 FIG. 5 is a right elevational view thereof broken away to indicate indeterminate length; and,
 FIG. 6 is a left elevational view thereof broken away to indicate indeterminate length.

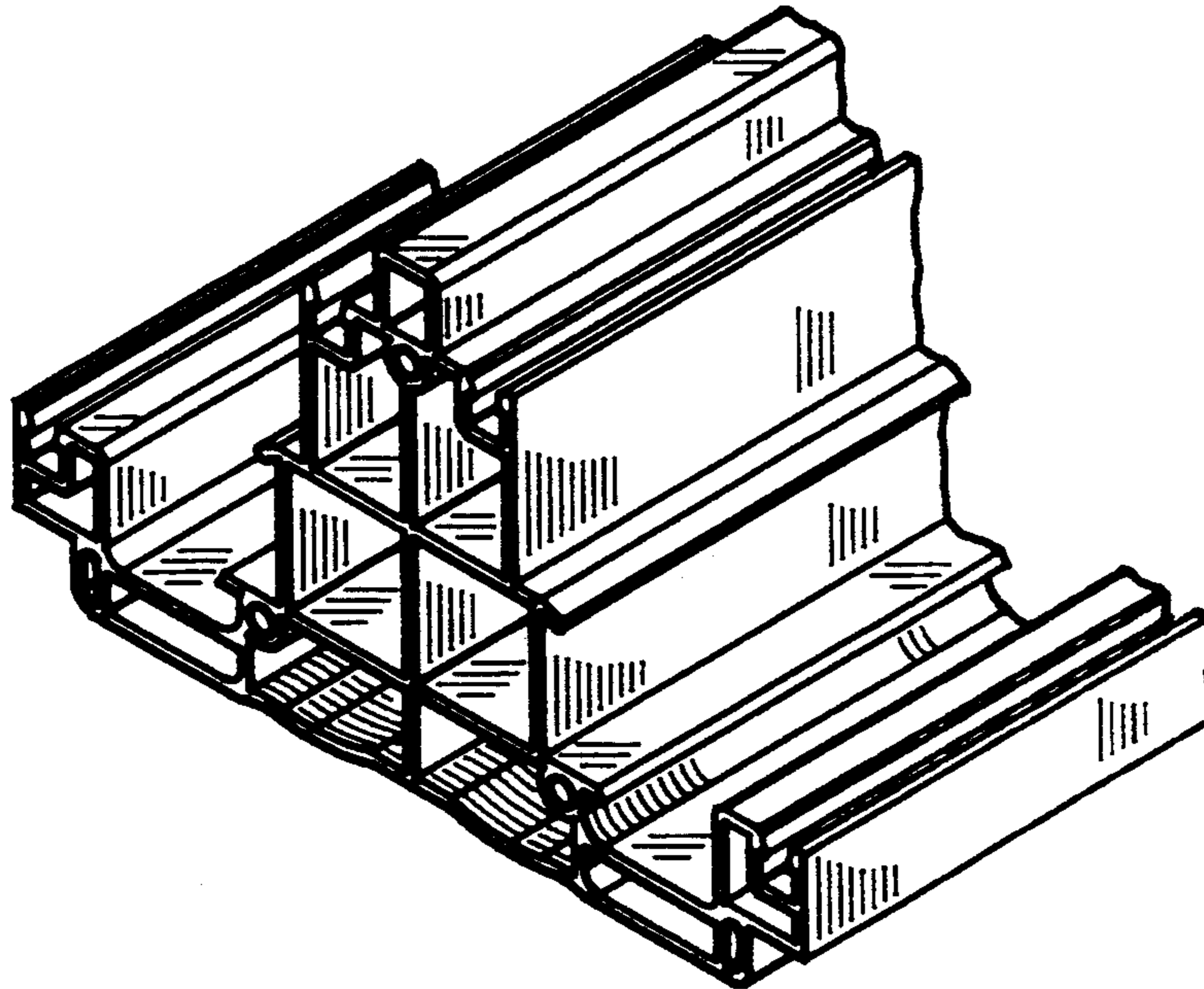

FIG. 1

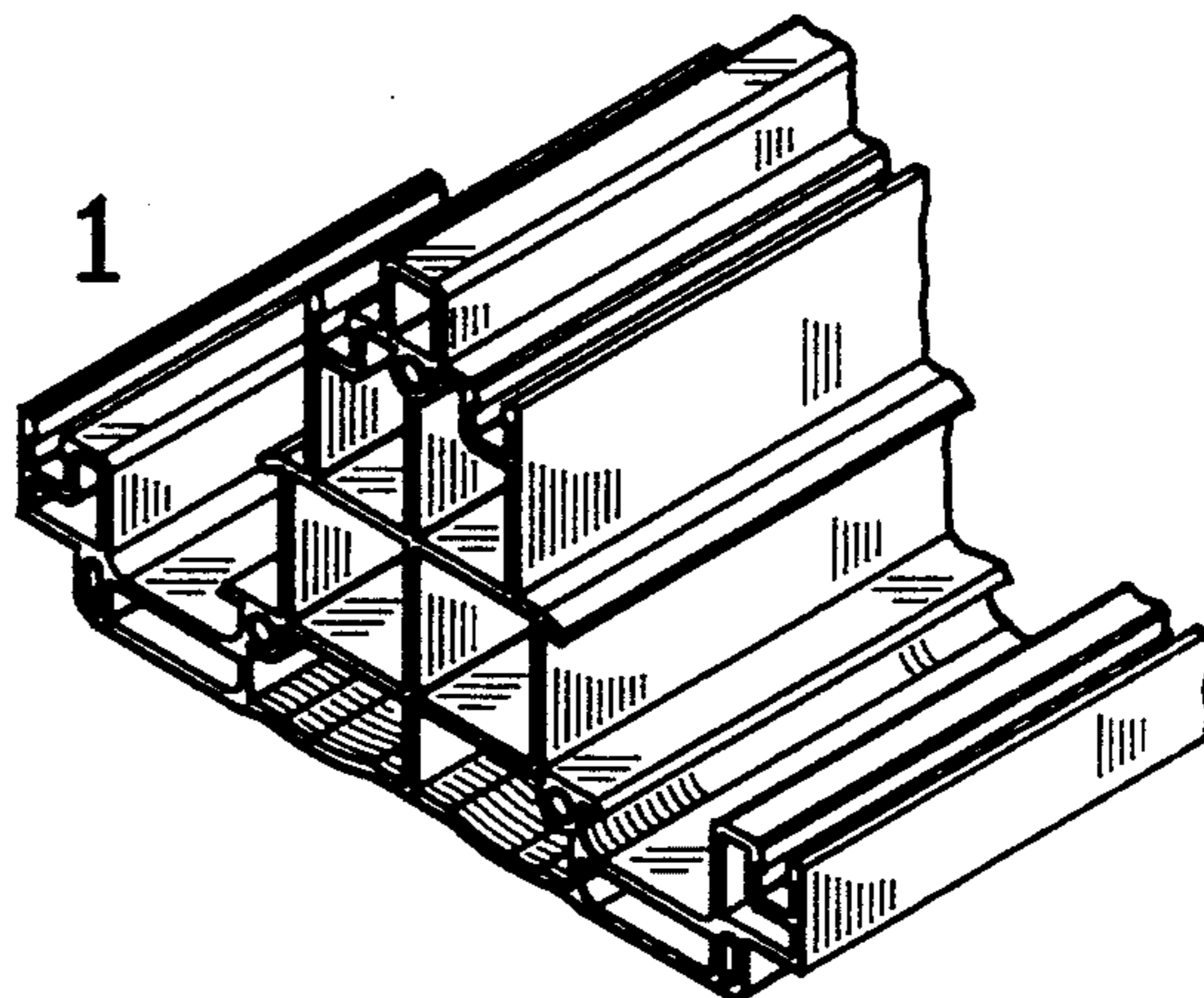

FIG. 2

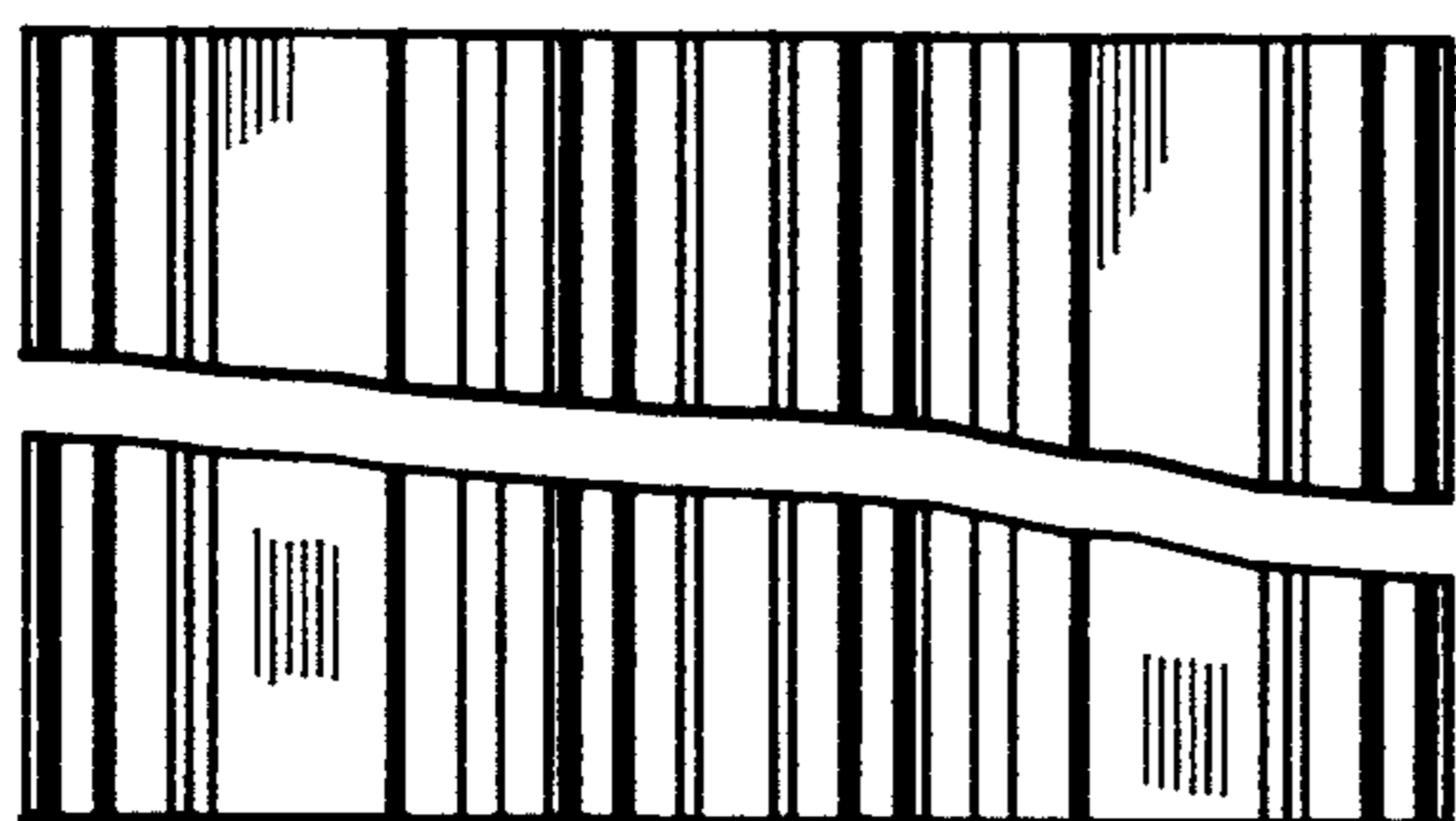

FIG. 3

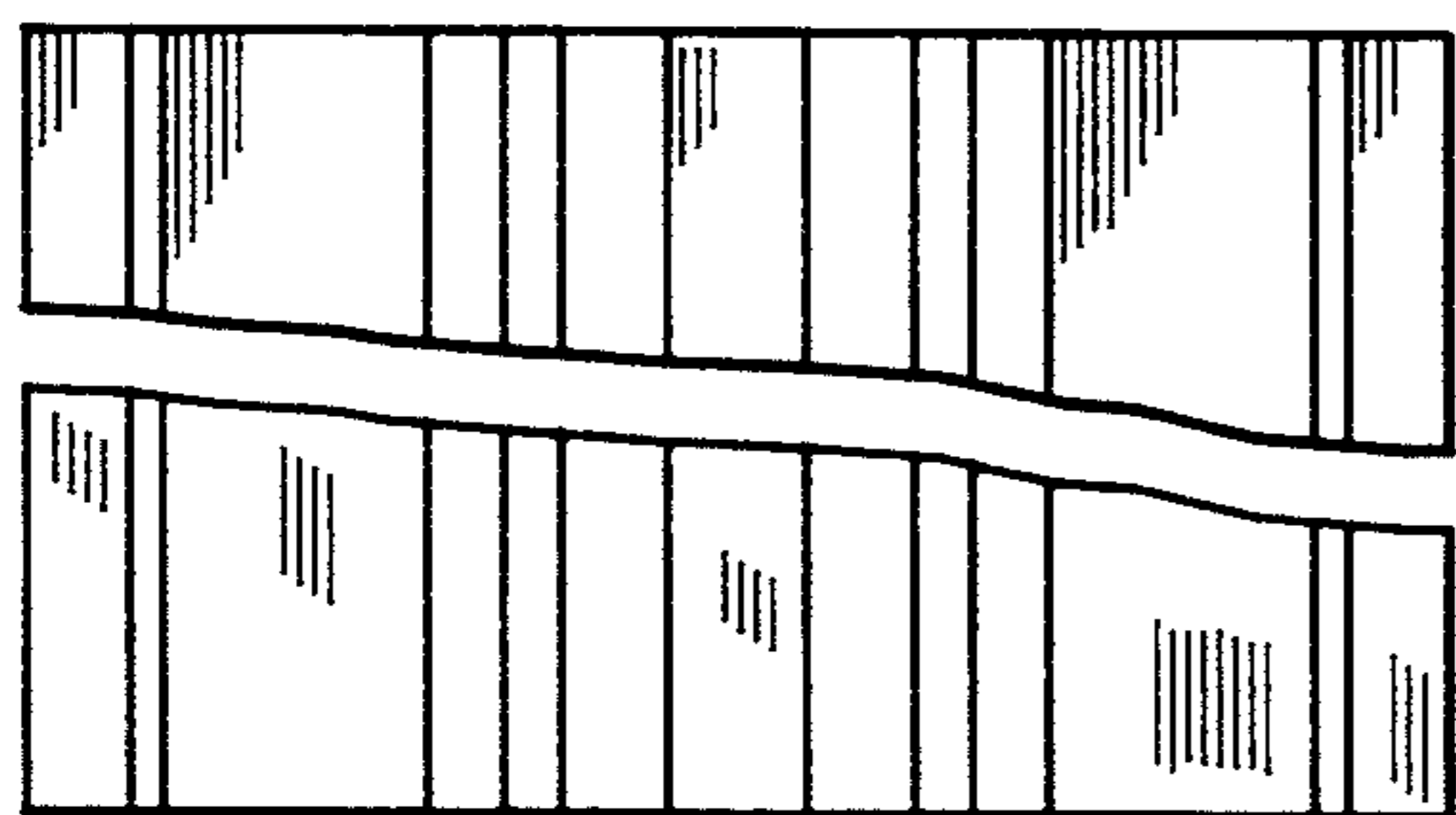

FIG. 4

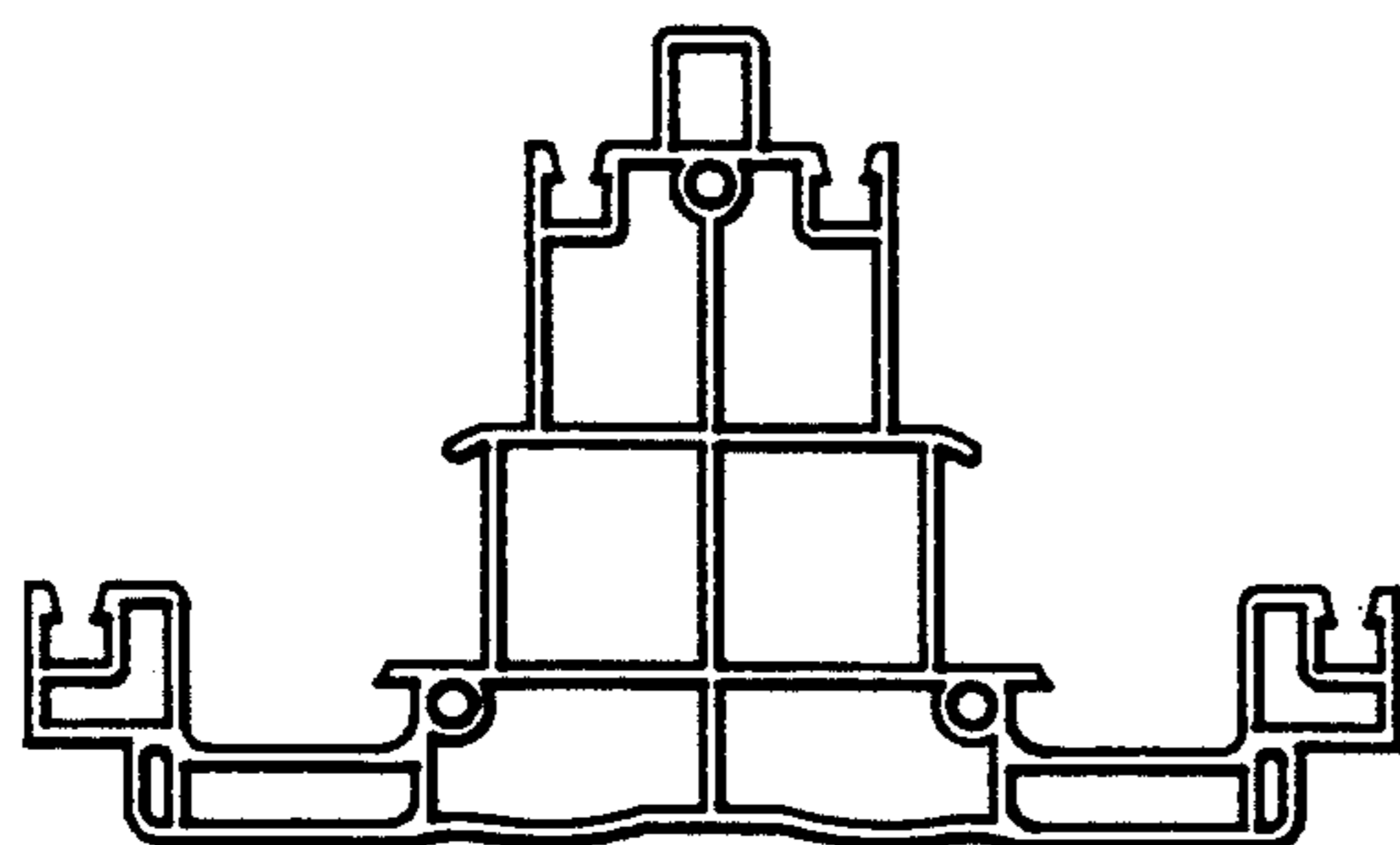

FIG. 5

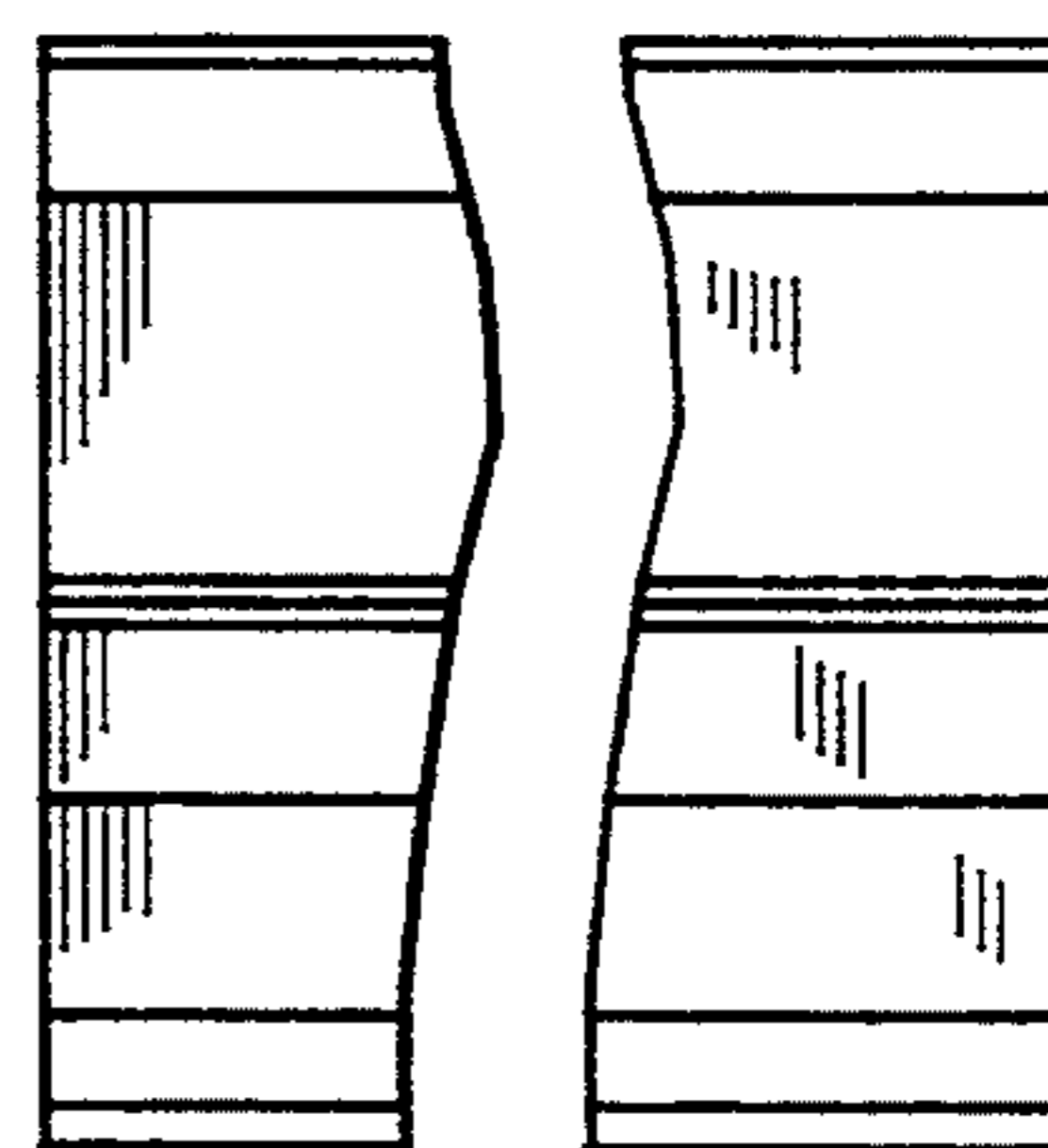

FIG. 6

