



US00D351603S

United States Patent [19]

[11] Patent Number: **Des. 351,603**

Ikeda et al.

[45] Date of Patent: **** Oct. 18, 1994**

[54] **COMPRESSOR FOR A VEHICLE AIR CONDITIONER**

D. 282,471	2/1986	Bearint et al.	D15/9
4,190,402	2/1980	Meece et al.	417/415
4,248,050	2/1981	Durenec	417/415
4,373,876	2/1983	Nemoto	417/539

[75] Inventors: **Hayato Ikeda; Muneharu Murase; Mitsuhiro Hattori; Koichi Ito**, all of Kariya, Japan

Primary Examiner—Ralf T. Seifert
Attorney, Agent, or Firm—Brooks Haidt Haffner & Delahunty

[73] Assignee: **Kabushiki Kaisha Toyota Jidoshokki Seisakusho**, Kariya, Japan

[57] CLAIM

[**] Term: **14 Years**

The ornamental design for a compressor for a vehicle air conditioner, as shown and described.

[21] Appl. No.: **787,972**

DESCRIPTION

[22] Filed: **Nov. 1, 1991**

[52] U.S. Cl. **D15/9**

[58] Field of Search 417/415, 419, 234, 233, 417/529, 539, 222, 231, 205; D15/1, 5, 7-9.1

FIG. 1 is a left side view of a compressor for a vehicle air conditioner;

FIG. 2 is a right side view thereof;

FIG. 3 is a front view thereof;

FIG. 4 is a bottom view thereof;

FIG. 5 is a rear view thereof;

FIG. 6 is a plan view thereof;

FIG. 7 is a front perspective view thereof; and,

FIG. 8 is a rear perspective view thereof.

[56] References Cited

U.S. PATENT DOCUMENTS

D. 245,779	9/1977	Nobata	D15/9
D. 273,587	4/1984	Hodgson	D15/5

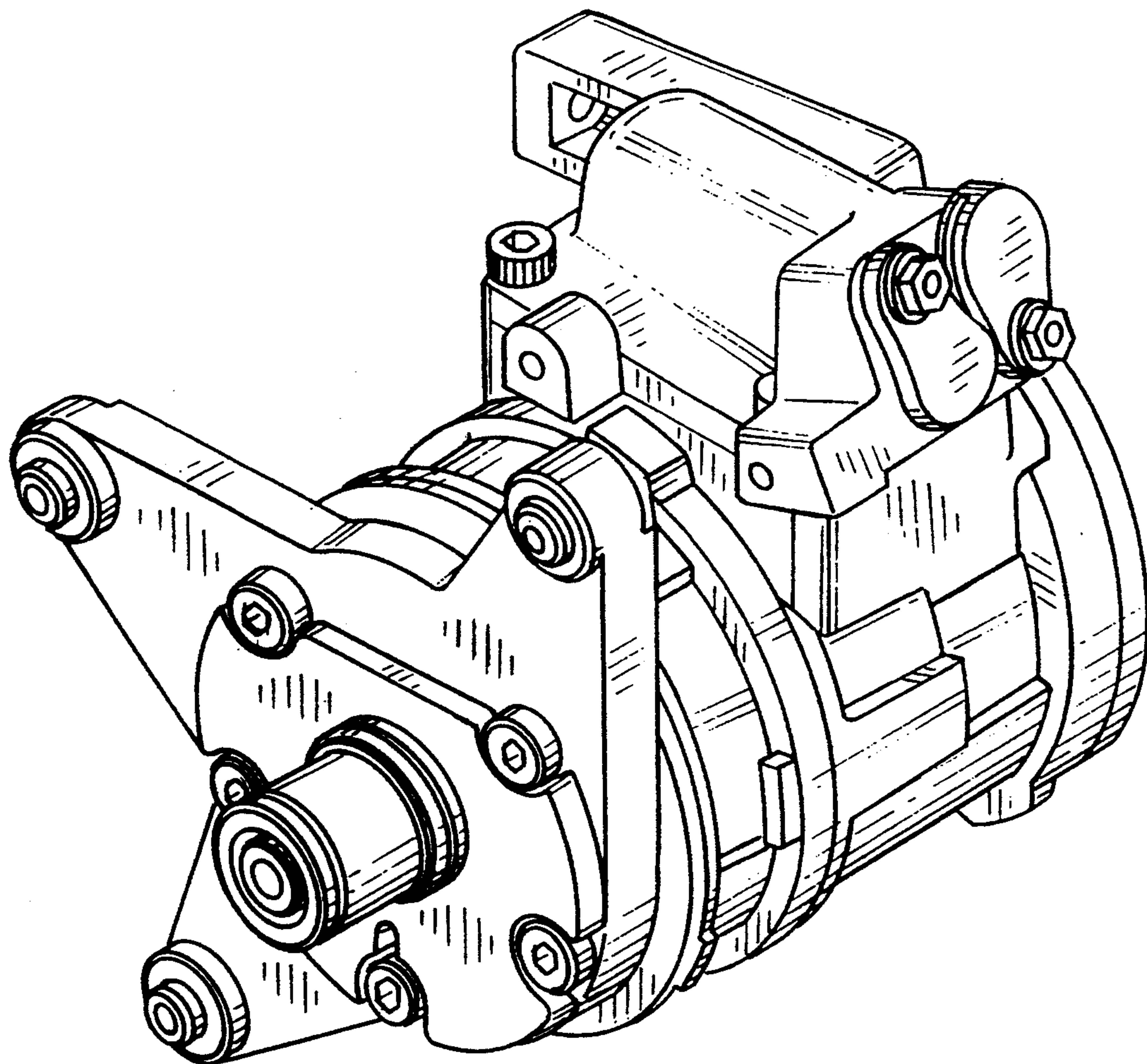

FIG. 1

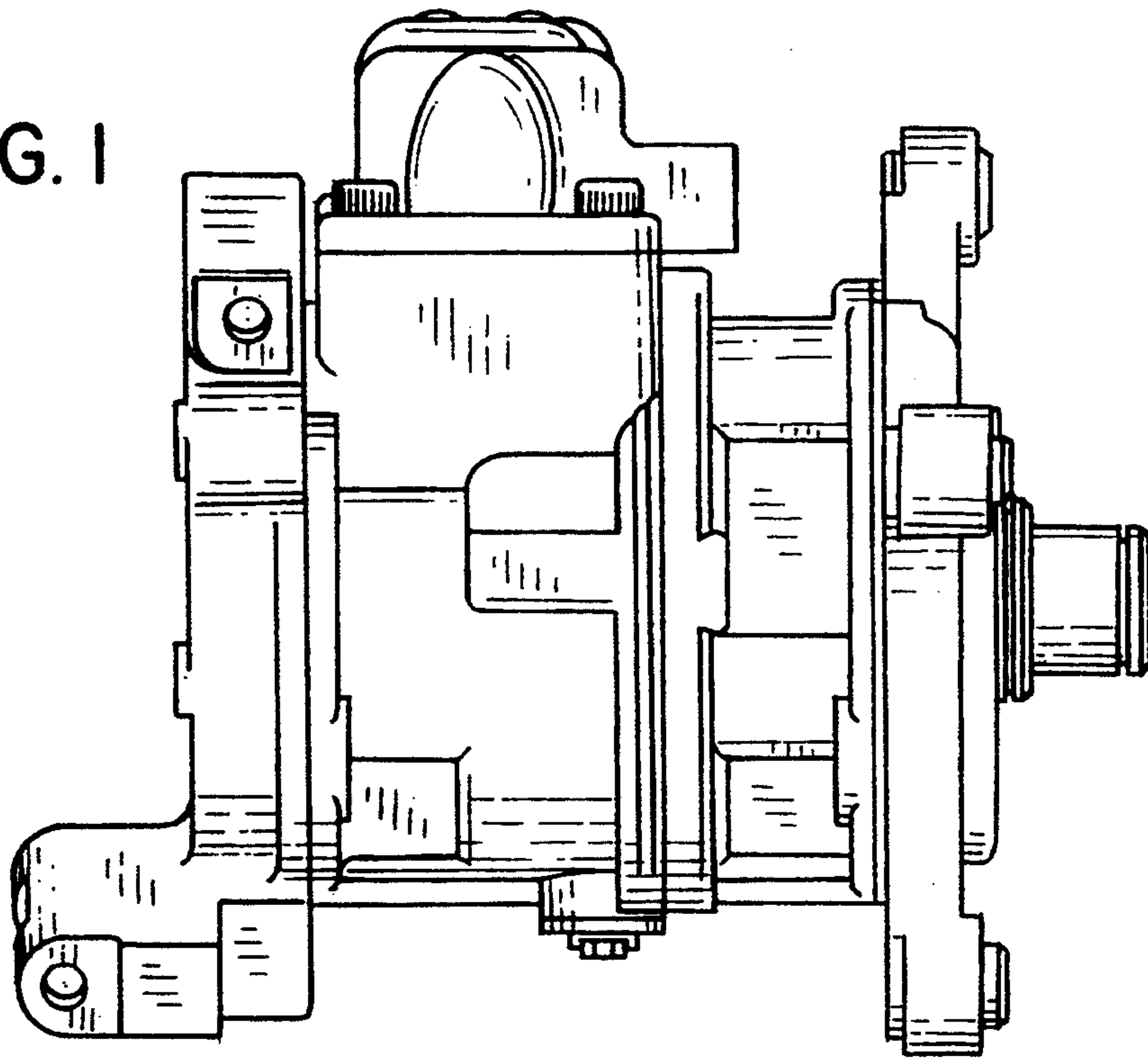

FIG. 2

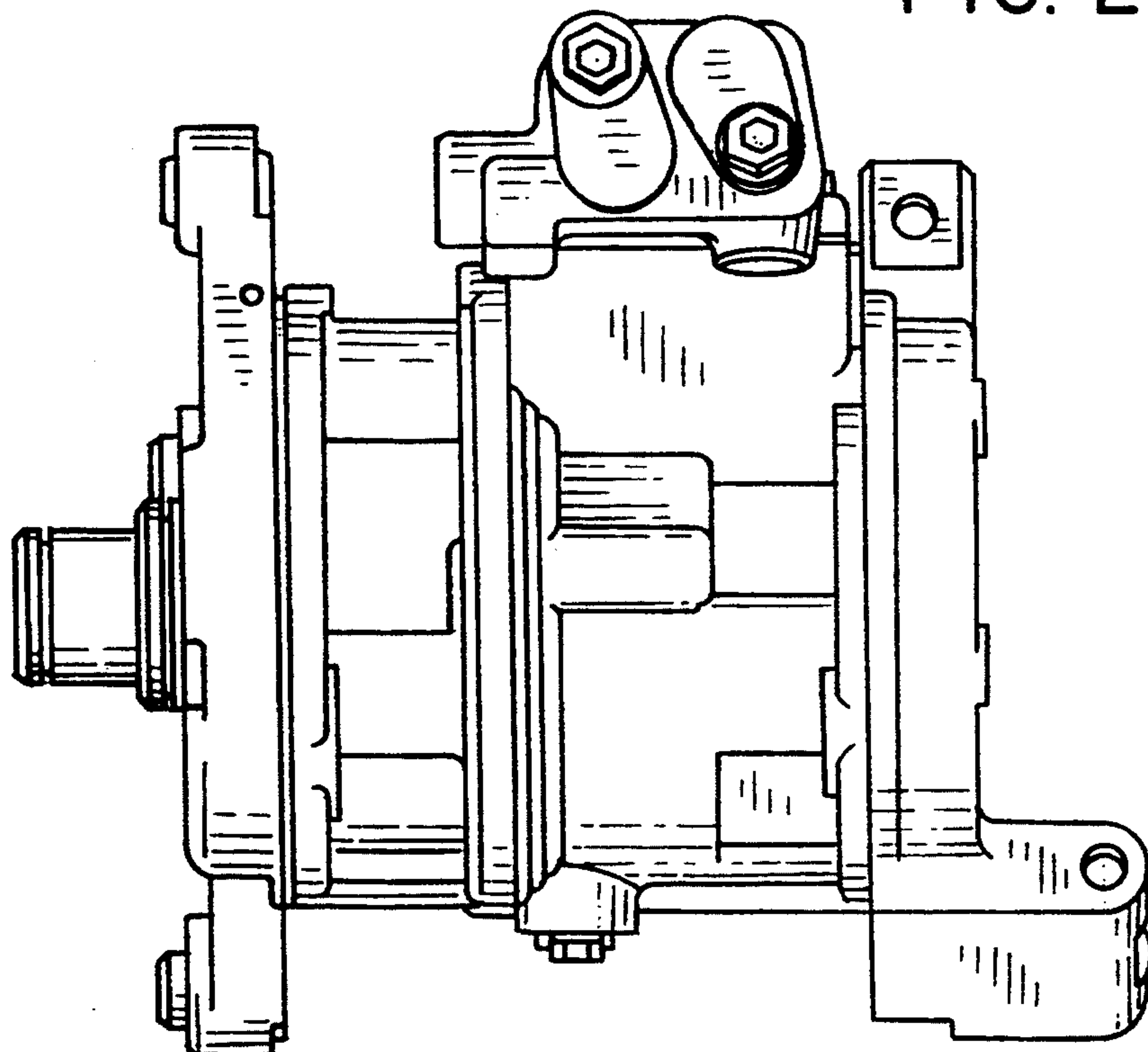

FIG. 3

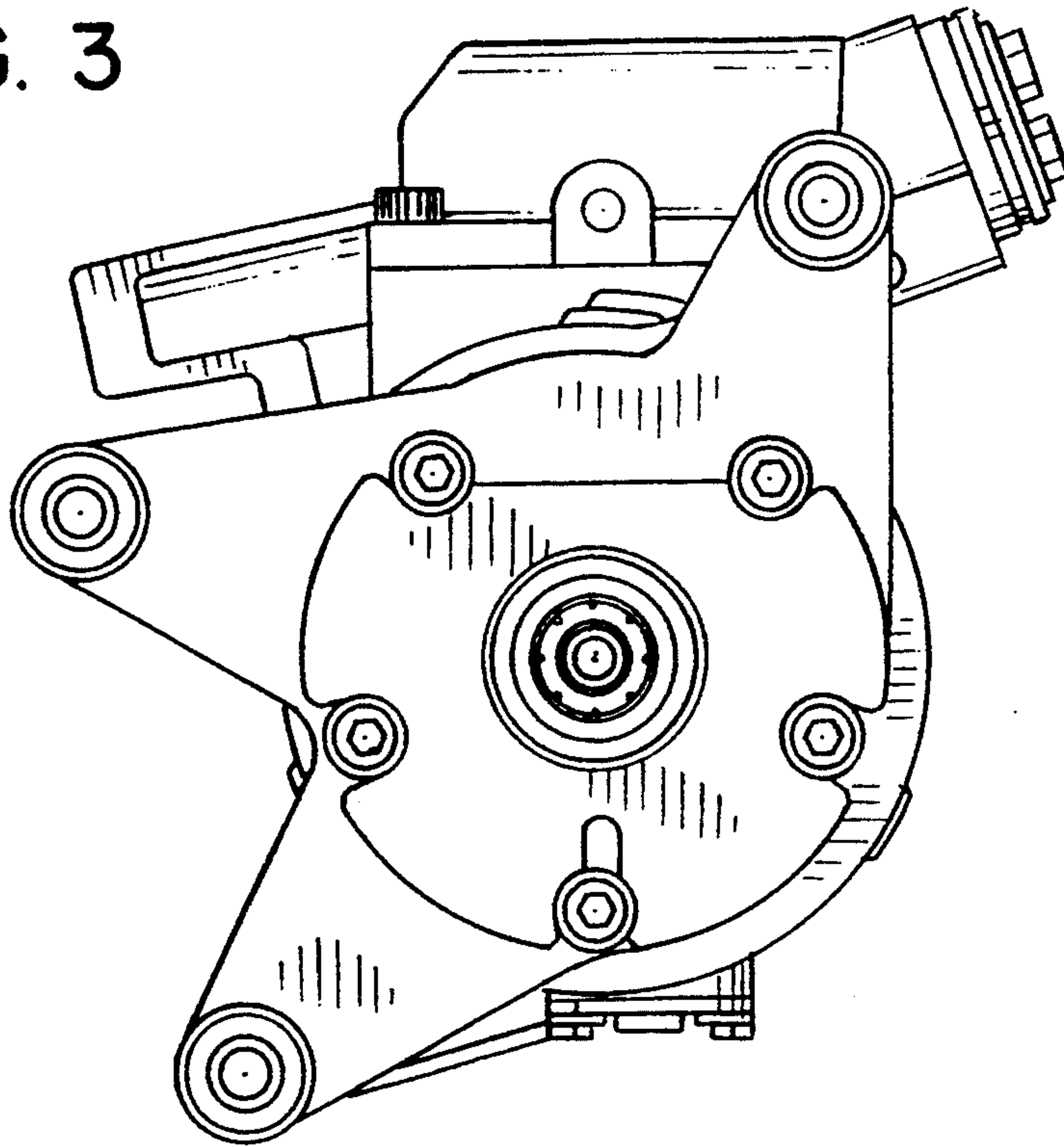
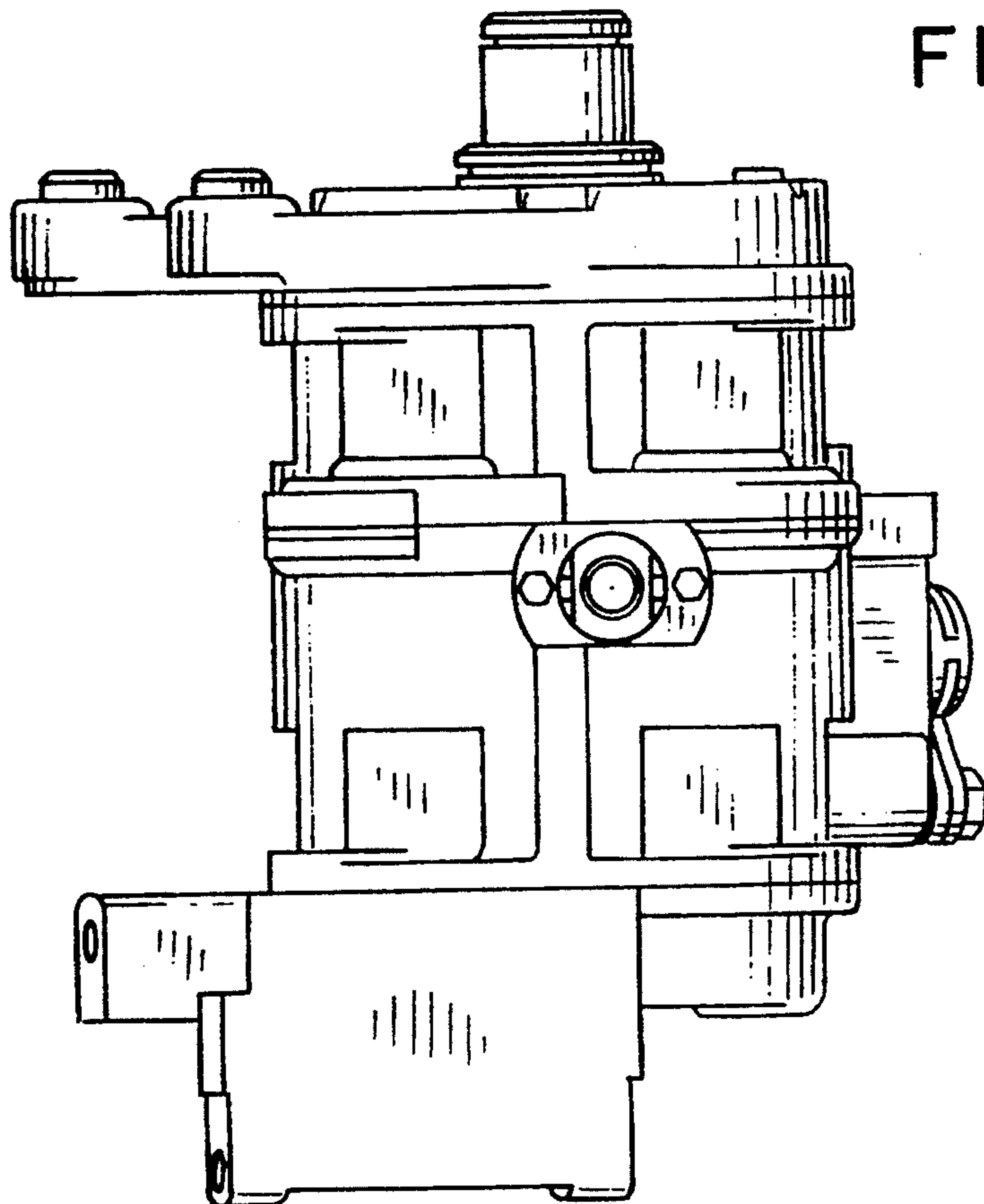

FIG. 4



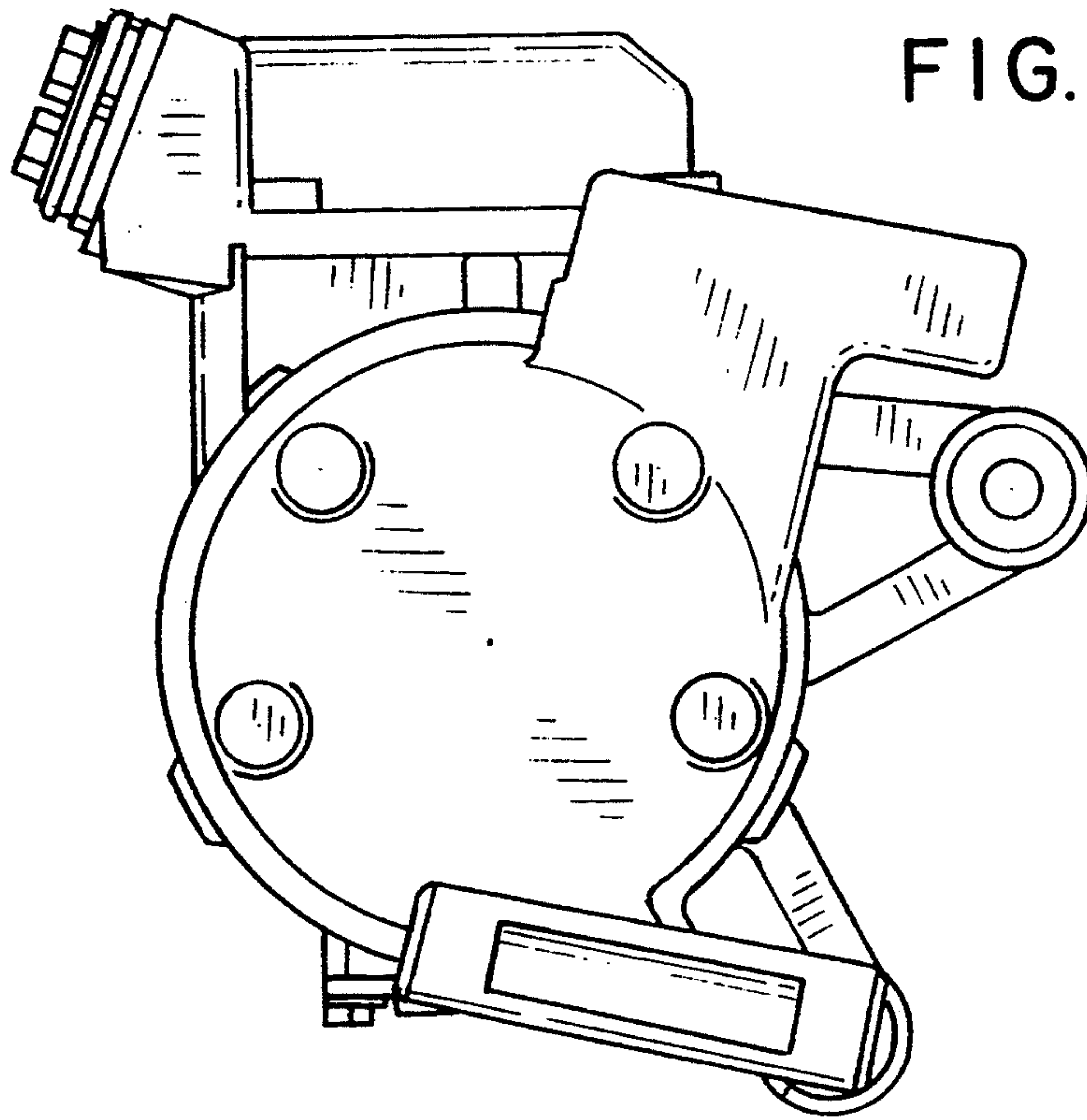

FIG. 5

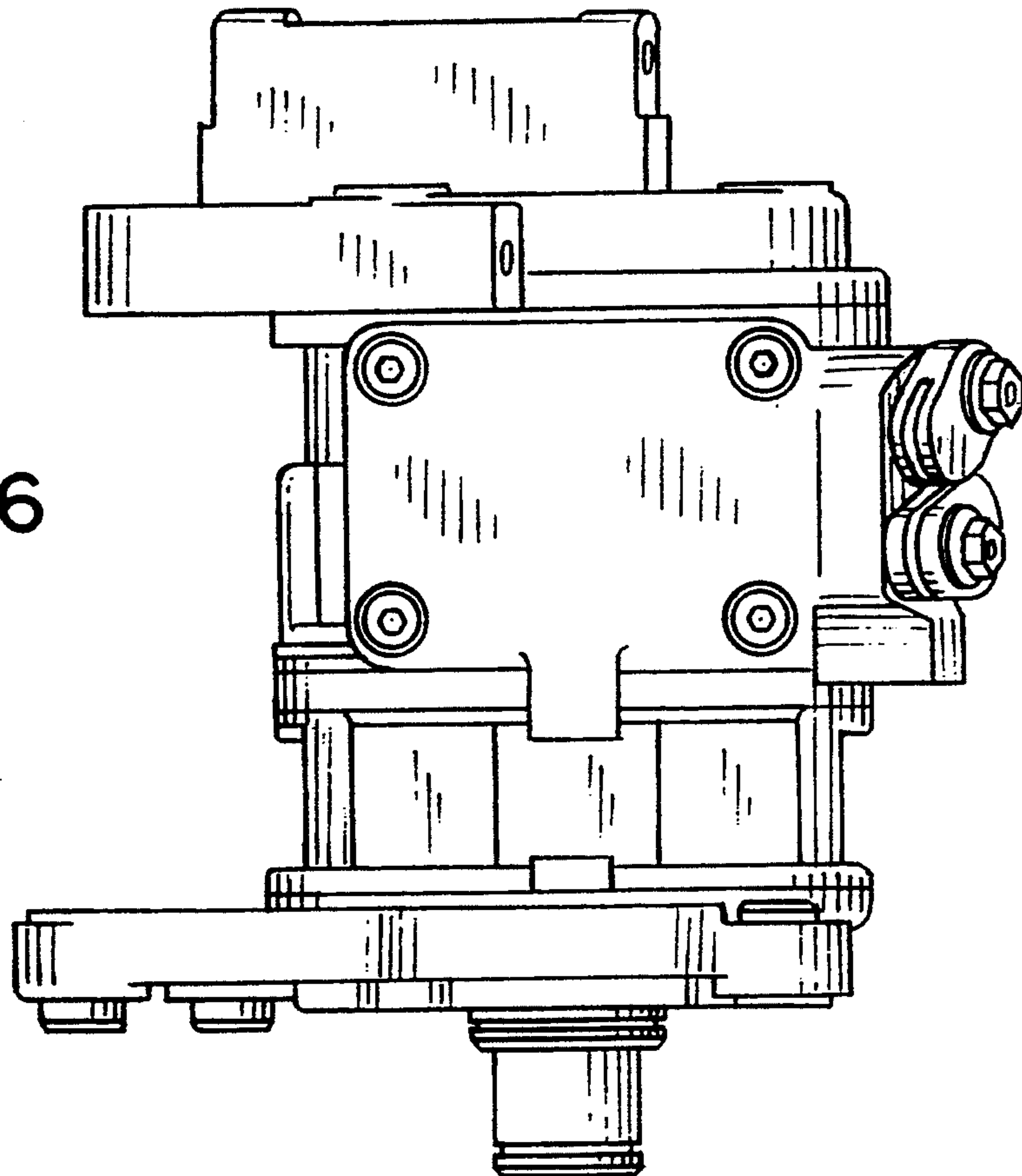

FIG. 6

FIG. 7

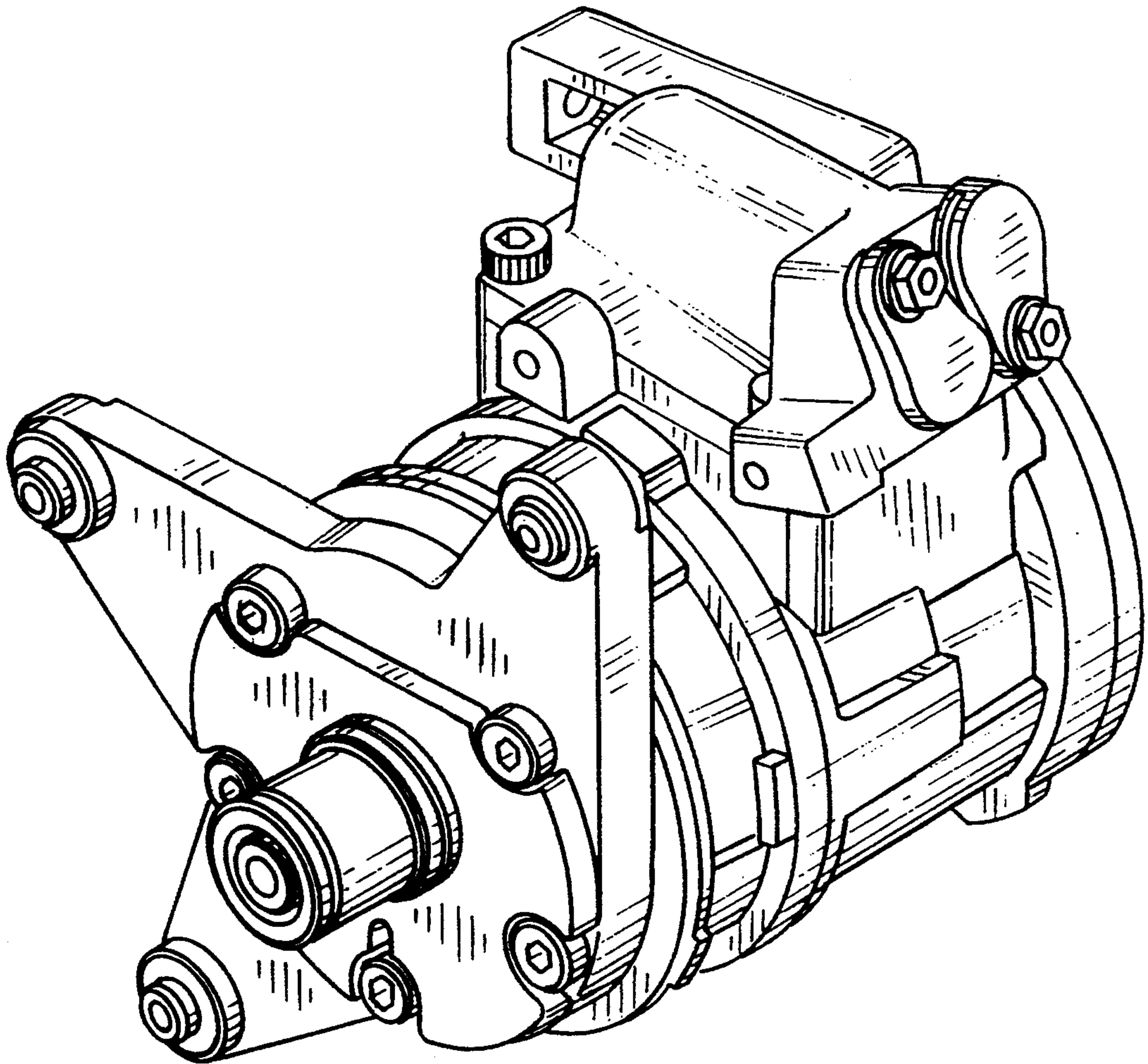

FIG. 8

