



US00D351478S

United States Patent [19]

Welton

[11] Patent Number: **Des. 351,478**

[45] Date of Patent: **** Oct. 11, 1994**

[54] **HALOGEN LANTERN**

[75] Inventor: **Gerry D. Welton, Morton, Ill.**

[73] Assignee: **Lamplighter Manufacturing, Inc., East Peoria, Ill.**

[**] Term: **14 Years**

[21] Appl. No.: **4,914**

[22] Filed: **Feb. 16, 1993**

[52] U.S. Cl. **D26/37**

[58] Field of Search 362/157, 158, 159, 160, 362/161, 168, 171, 172, 173, 178, 179, 180, 183, 184, 186, 190, 197, 198, 201, 202, 203, 204, 205, 206, 207, 208; D26/37-50

[56] **References Cited**

U.S. PATENT DOCUMENTS

| | | | |
|------------|--------|-------------------|---------|
| D. 284,106 | 6/1986 | Drane | D26/50 |
| 3,124,306 | 3/1964 | Schotz | 362/157 |
| 3,252,733 | 5/1966 | Moore et al. | D26/48 |

| | | | |
|-----------|---------|-------------------|---------|
| 3,329,810 | 7/1967 | Meagher | 362/158 |
| 3,471,849 | 10/1969 | Cheng | 362/190 |
| 4,339,788 | 7/1982 | White et al. | 362/157 |

Primary Examiner—Wallace R. Burke
Assistant Examiner—Marcus Jackson
Attorney, Agent, or Firm—Hill, Steadman & Simpson

[57] **CLAIM**

The ornamental design for a halogen lantern, as shown and described.

DESCRIPTION

FIG. 1 is a front, right side perspective view of a halogen lantern showing my new design; FIG. 2 is a front elevational view thereof; FIG. 3 is a rear elevational view thereof; FIG. 4 is a left side elevational view thereof; FIG. 5 is a top plan view thereof; FIG. 6 is a bottom plan view thereof; and, FIG. 7 is a right side elevational view thereof showing the halogen lantern angularly supported on an extendable leg member.

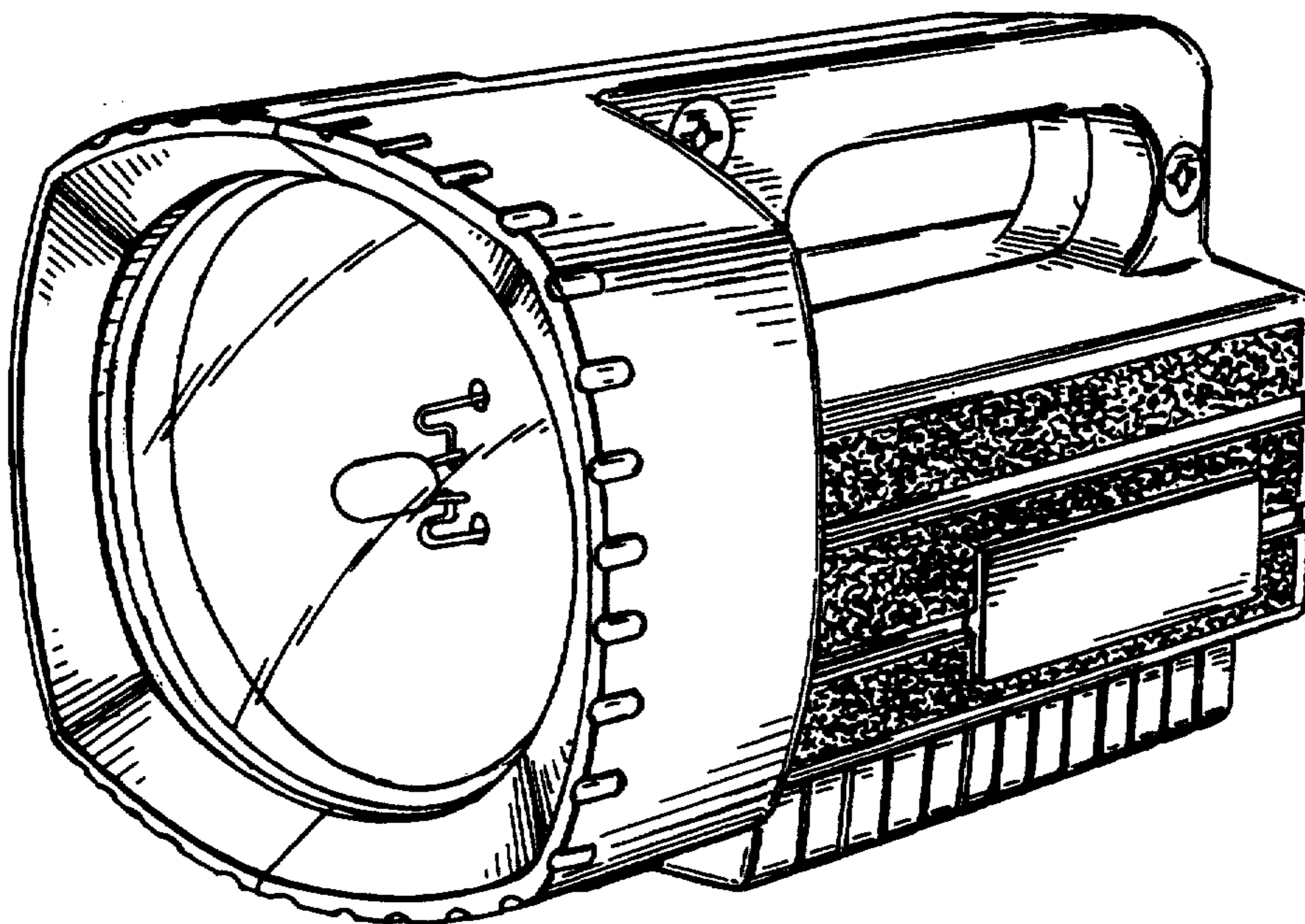

FIG. 1

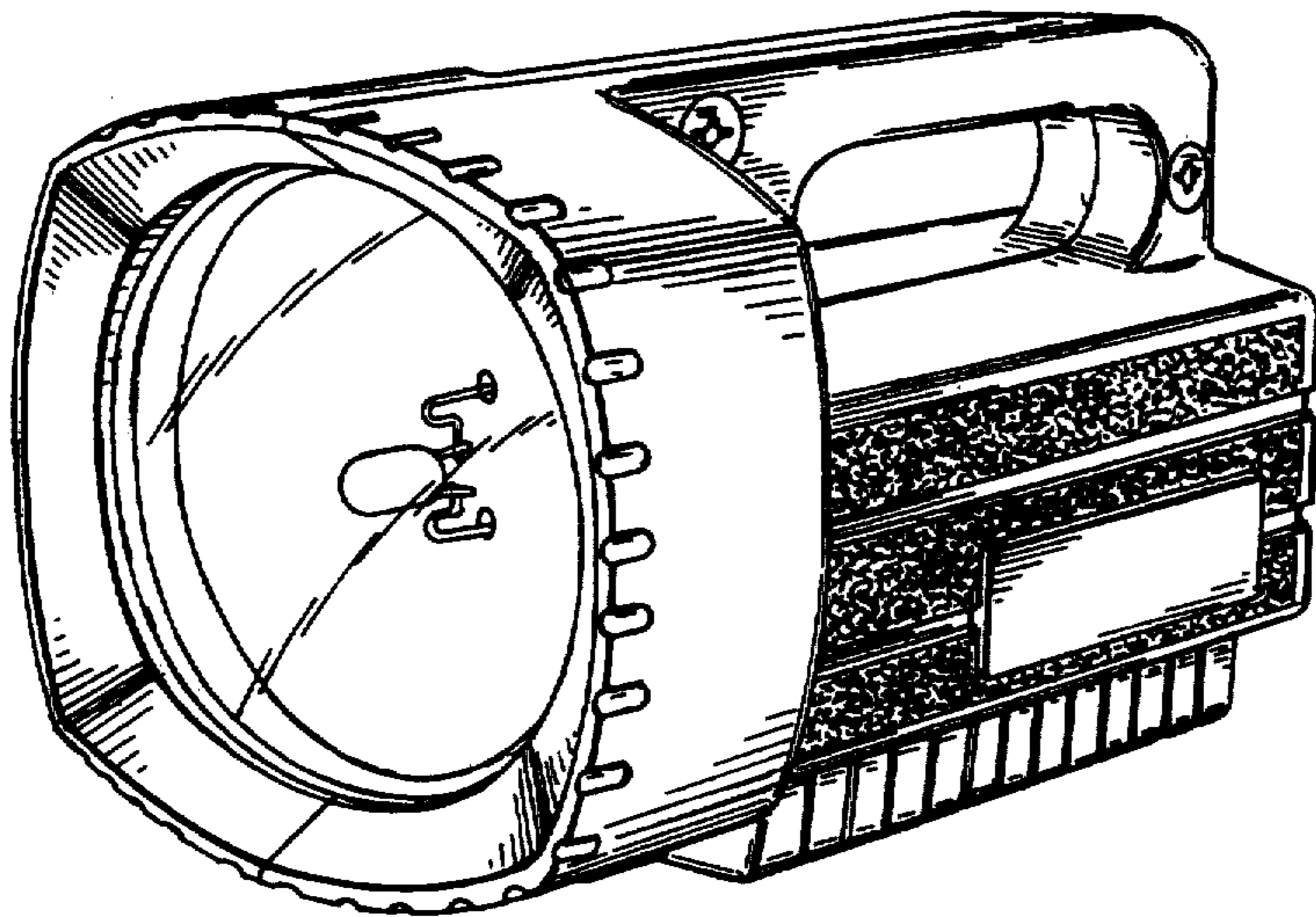

FIG. 2

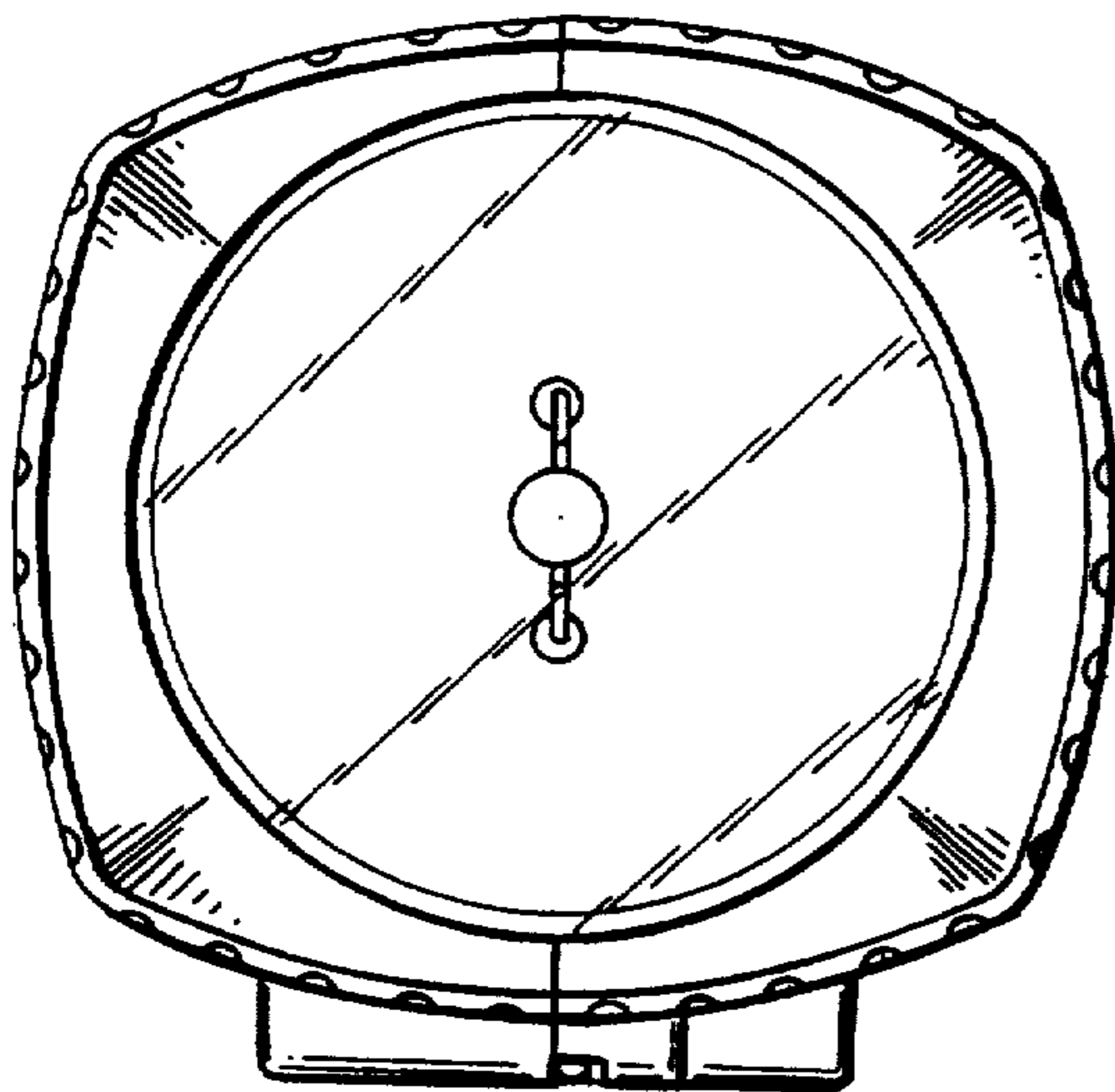

FIG. 3

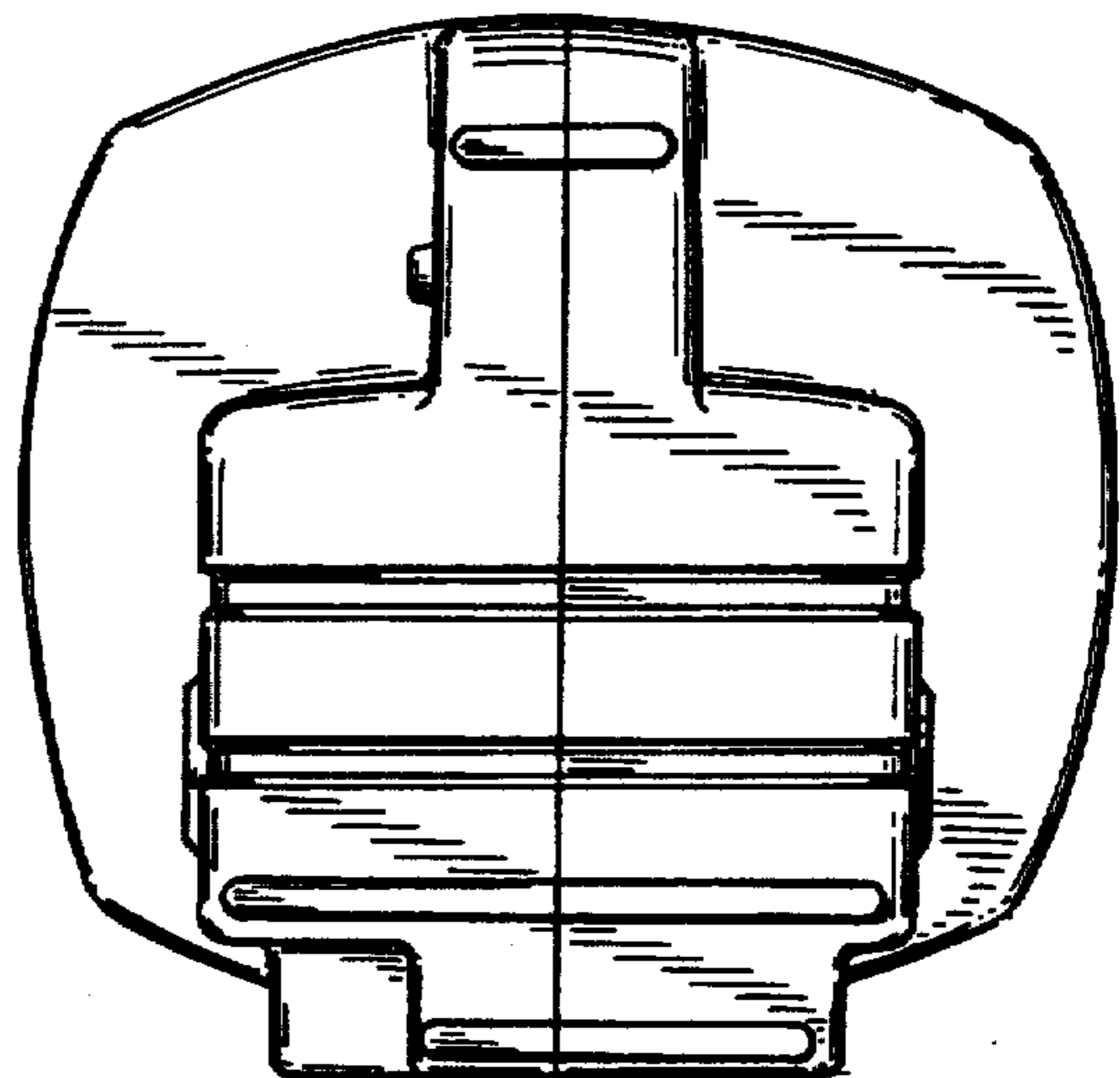

FIG. 4

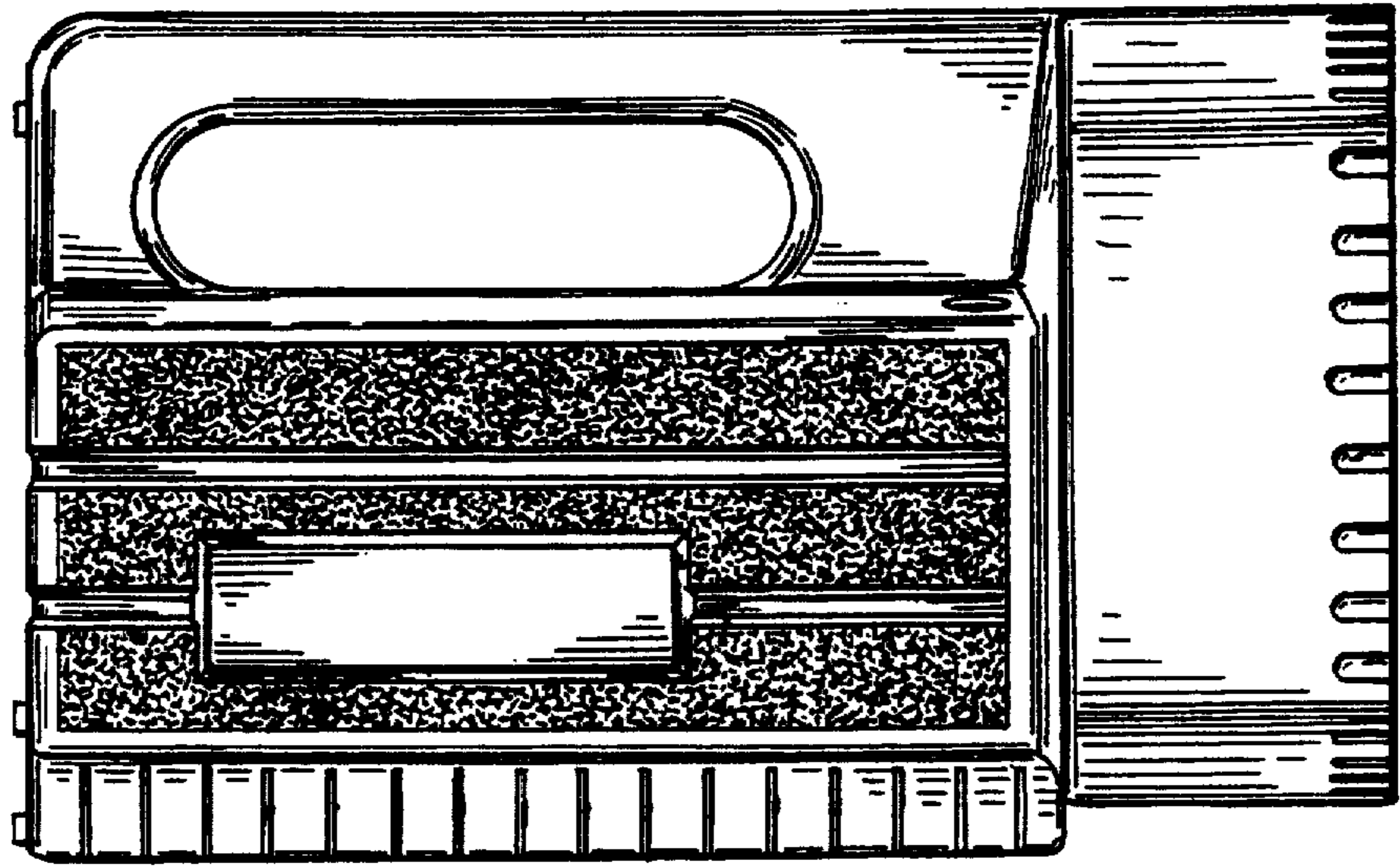

FIG. 5

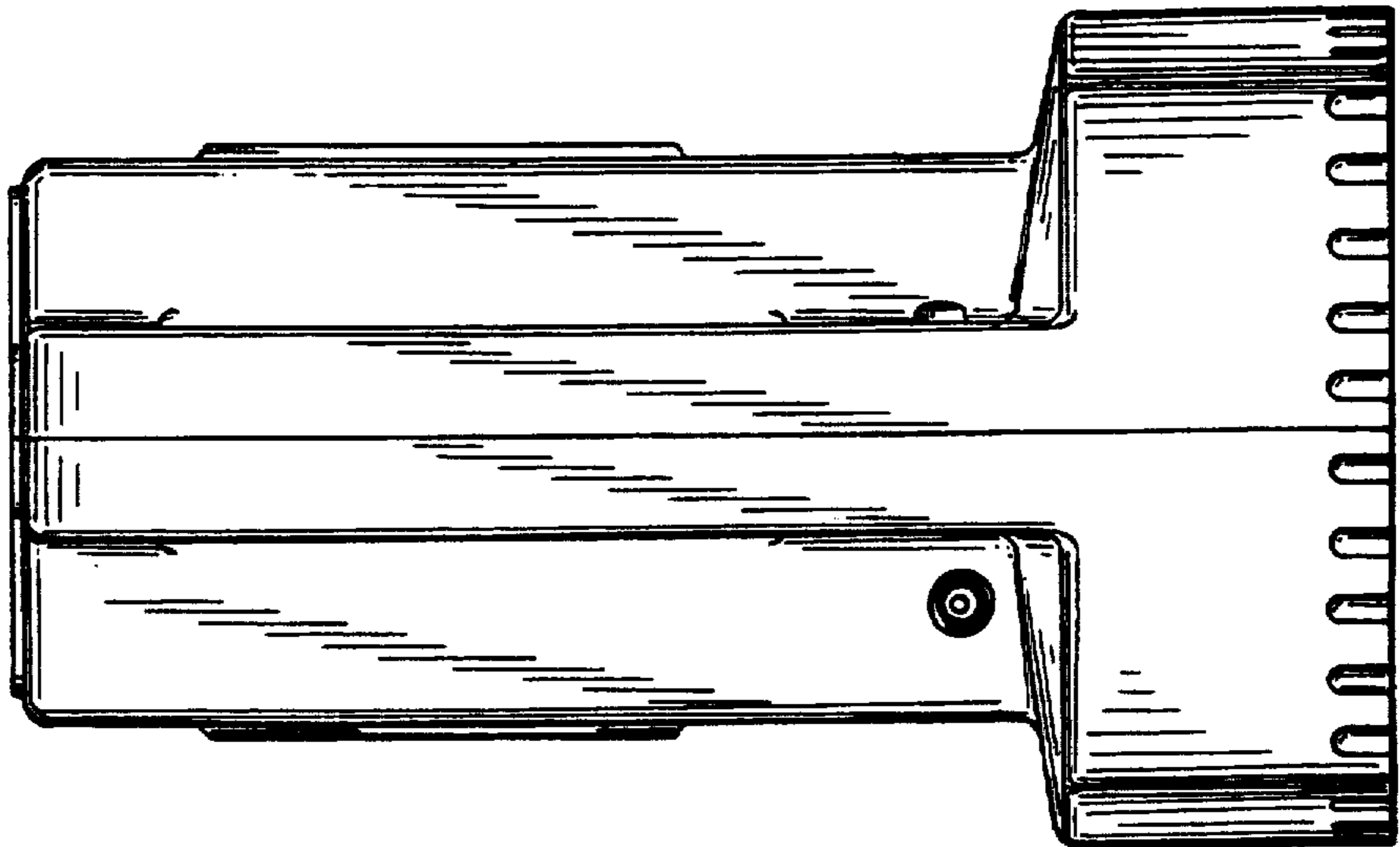

FIG. 6

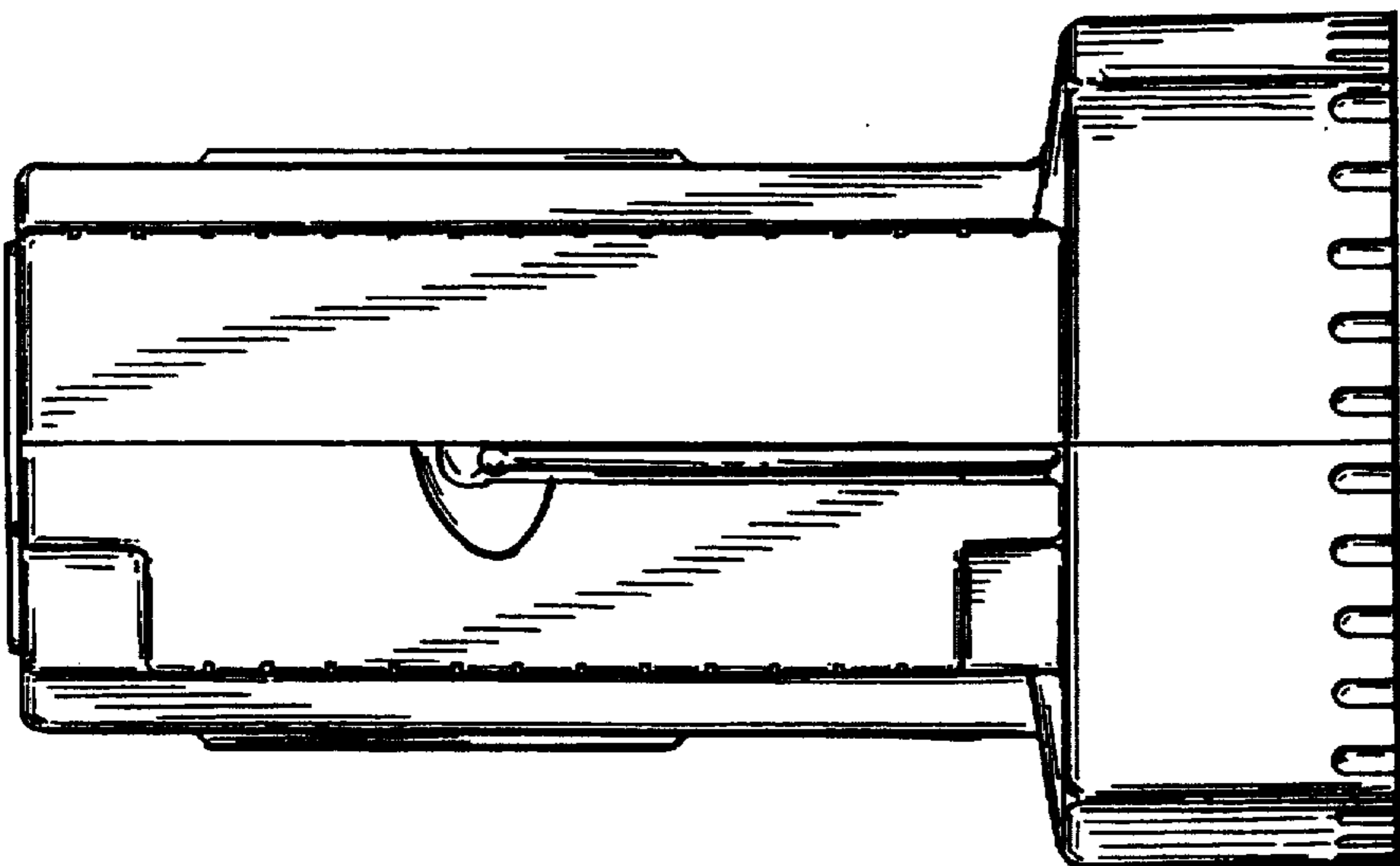

FIG. 7

