



US00D351301S

United States Patent [19]
Adamson

[11] **Patent Number: Des. 351,301**

[45] **Date of Patent: ** Oct. 11, 1994**

[54] **RIB FOR A SEATING UNIT**

[76] **Inventor: Gerald J. Adamson, 267 Glen Manor Drive, East, Toronto, Canada, M4E 2Y3**

[**] **Term: 14 Years**

[21] **Appl. No.: 212**

[22] **Filed: Oct. 8, 1992**

[52] **U.S. Cl. D6/501; D6/502**

[58] **Field of Search D6/334, 370, 371, 373, D6/374, 375, 376, 379, 381, 500, 501, 502; 297/232, 411.44, DIG. 2**

[56] **References Cited**

U.S. PATENT DOCUMENTS

D. 165,952	2/1952	Weatherly	D6/375
D. 225,946	1/1973	Morrison et al.	D6/373
D. 233,964	12/1974	Morrison et al.	D6/373
D. 233,965	12/1974	Morrison et al.	D6/373
D. 233,966	12/1974	Morrison et al.	D6/373
D. 233,967	12/1974	Morrison et al.	D6/373
D. 294,782	3/1988	Balderi	D6/373
3,719,389	3/1973	Burton et al.	D6/375
4,119,286	10/1978	Barril	D6/375

OTHER PUBLICATIONS

Industrial Design, Mar./Apr. 1976, p. 27, Chair at top right.

Industrial Design, Nov./Dec. 1977, p. 47, chair at top left.

Interiors, Dec. 1990, p. 107, Bench at bottom right.

Primary Examiner—Alan P. Douglas

Assistant Examiner—Gary D. Watson

Attorney, Agent, or Firm—Bereskin & Parr

[57] **CLAIM**

The ornamental design for a rib for a seating unit, as shown and described.

DESCRIPTION

FIG. 1 is a perspective view of a rib for a seating unit showing my new design;

FIG. 2 is a right side elevational view, the left side being a mirror image thereof;

FIG. 3 is a front elevational view;

FIG. 4 is a rear elevational view;

FIG. 5 is a top plan view;

FIG. 6 is a bottom plan view;

FIG. 7 is a perspective view of a rib for a seating unit showing a second embodiment of my new design;

FIG. 8 is a right side elevational view of FIG. 7, the left side being a mirror image thereof;

FIG. 9 is a front elevational view of FIG. 7; and,

FIG. 10 is a top plan view of FIG. 7.

The rear elevational view and the bottom plan view of FIG. 7 are identical to FIGS. 4 and 6 respectively.

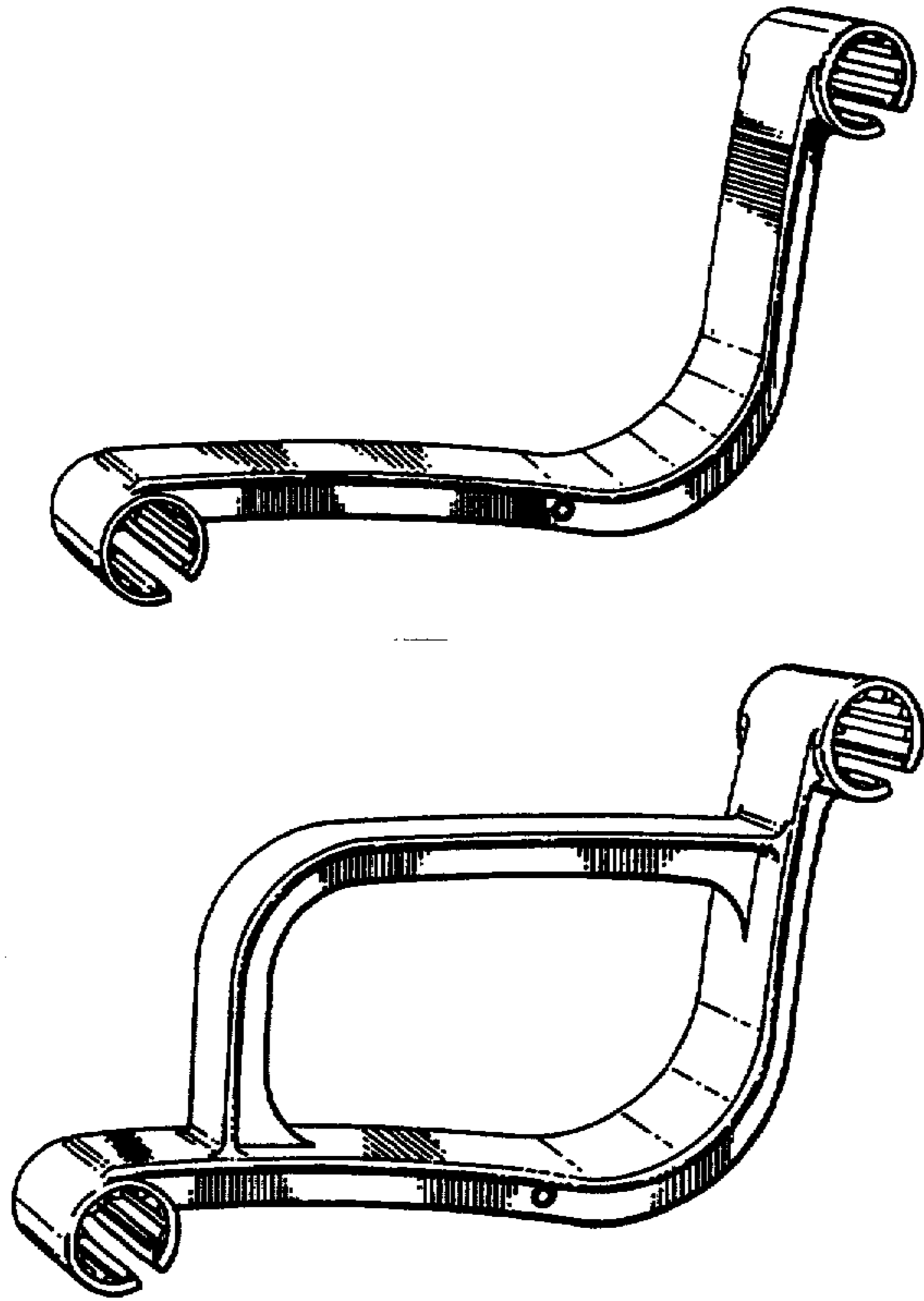

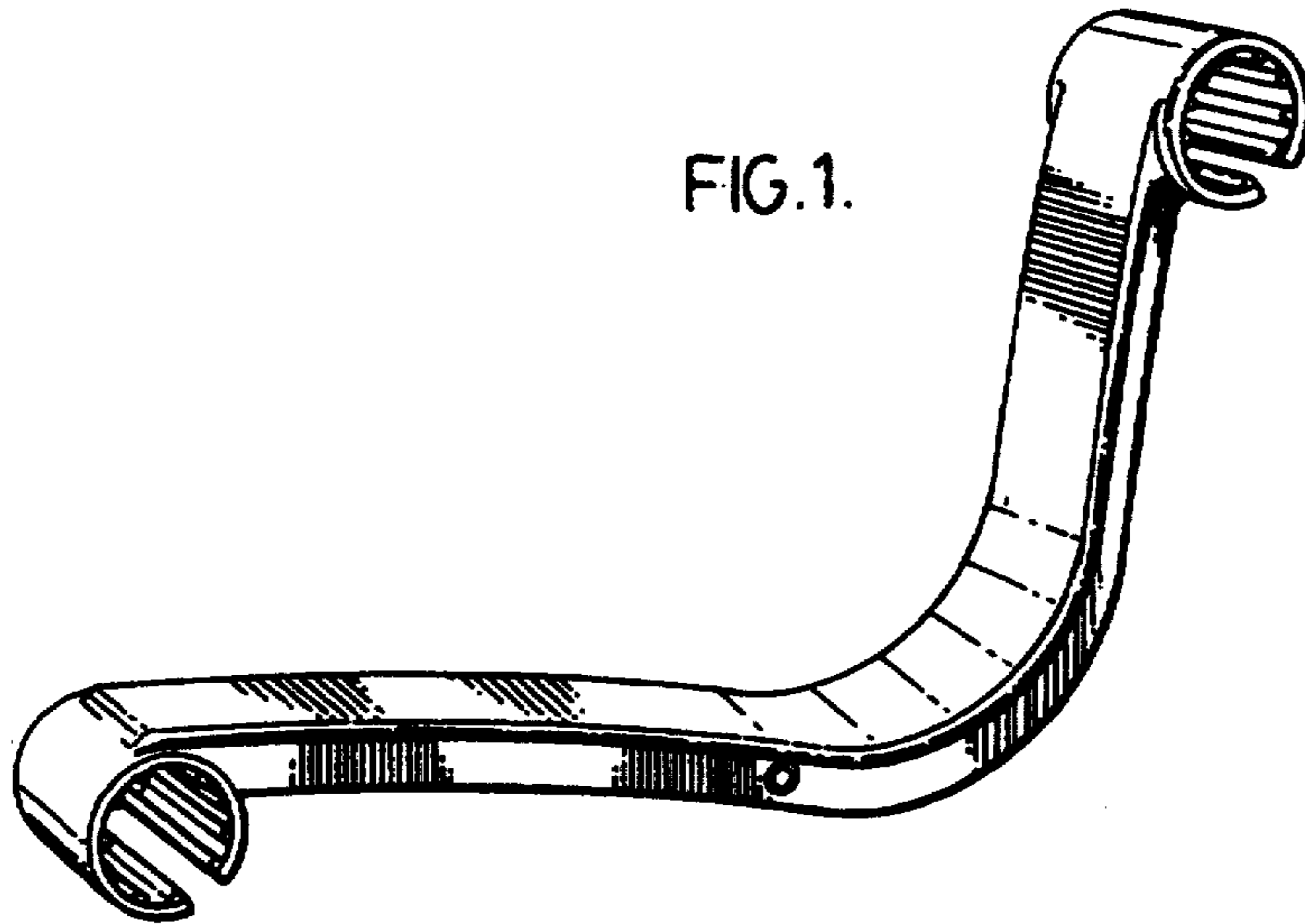

FIG. 3.

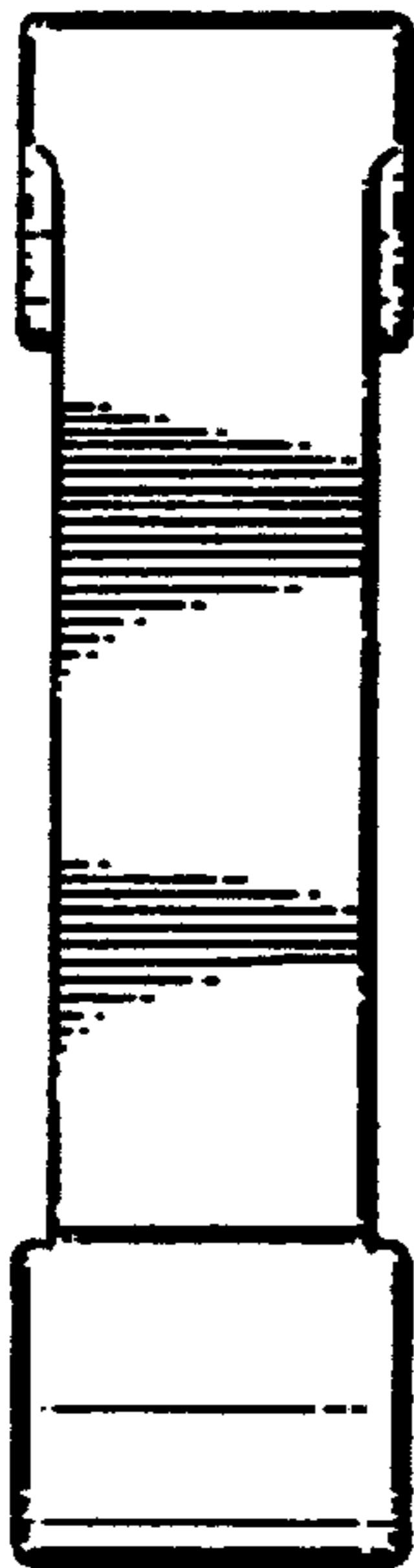

FIG. 4.

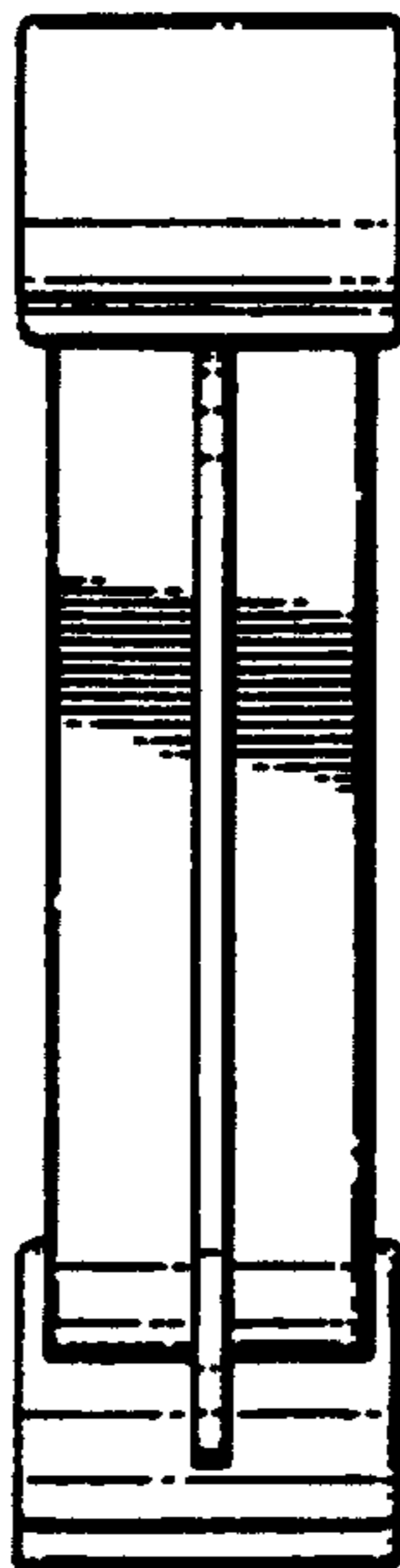

FIG. 2.

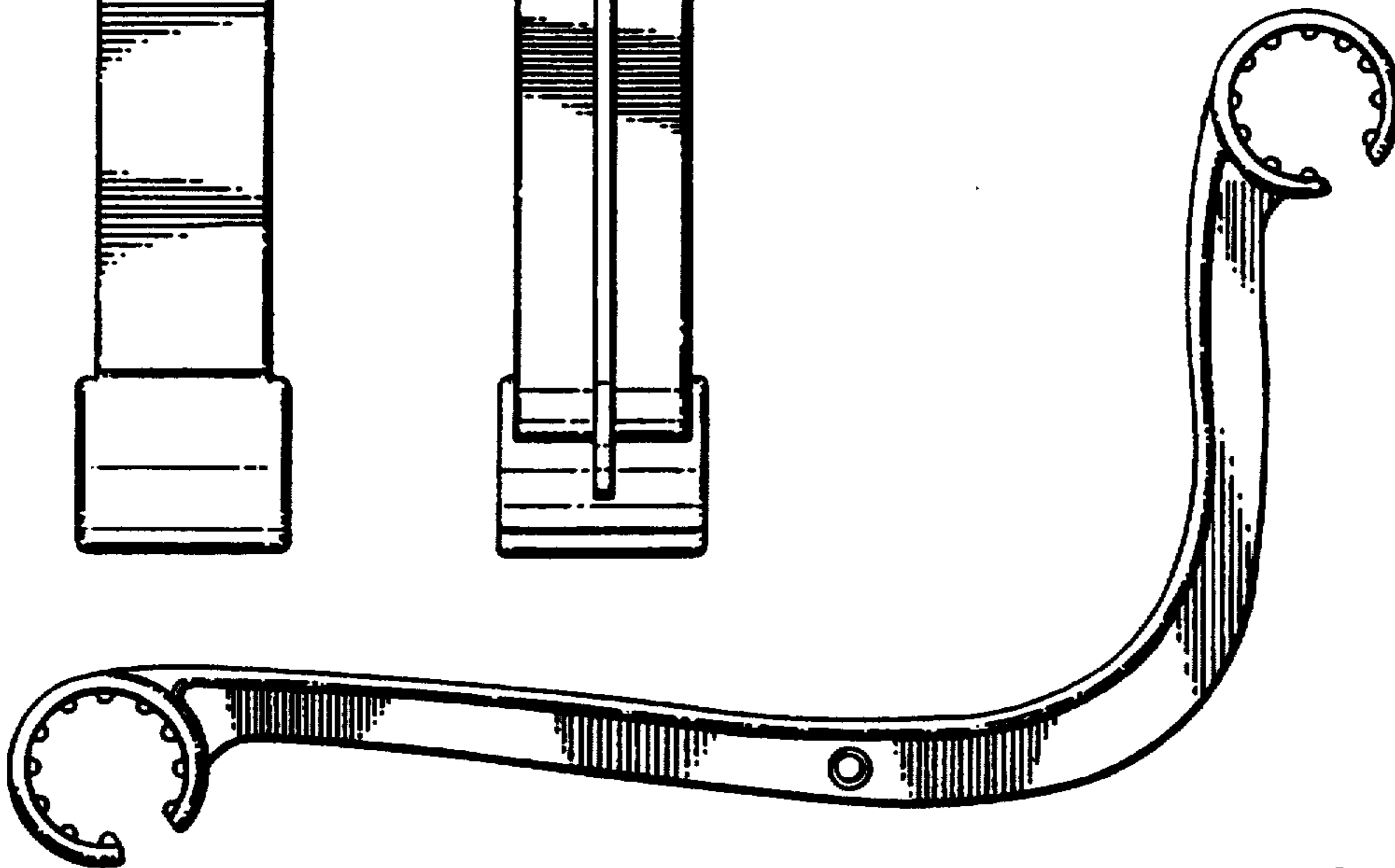

FIG. 5.

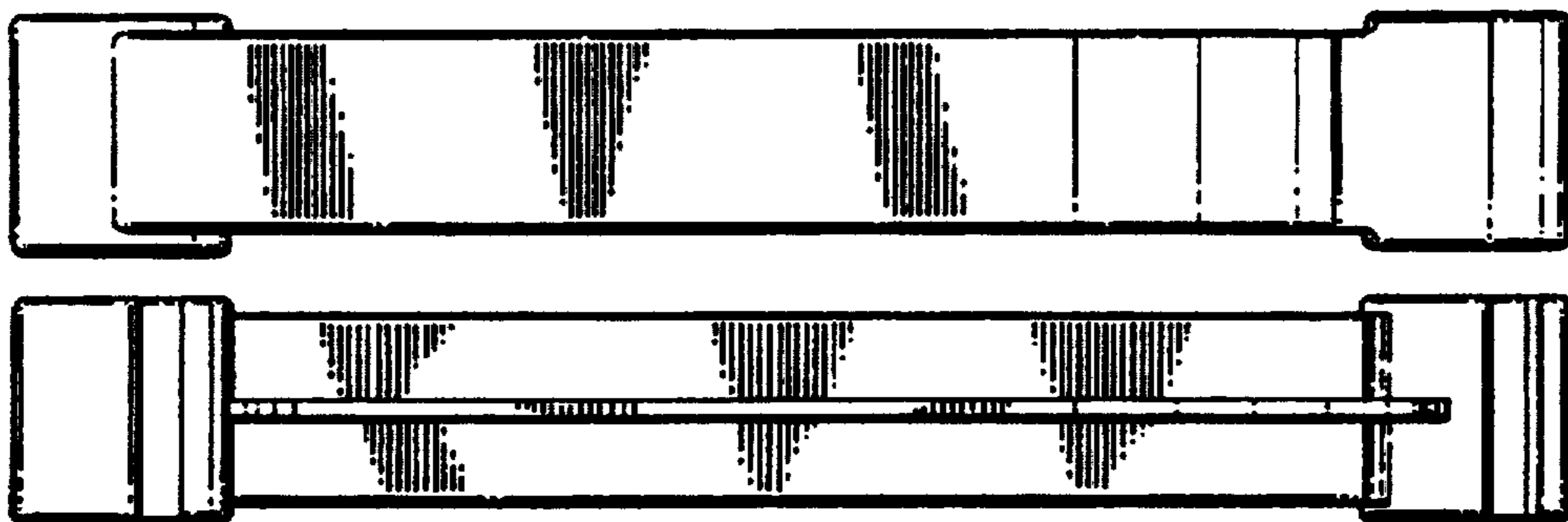

FIG. 6.

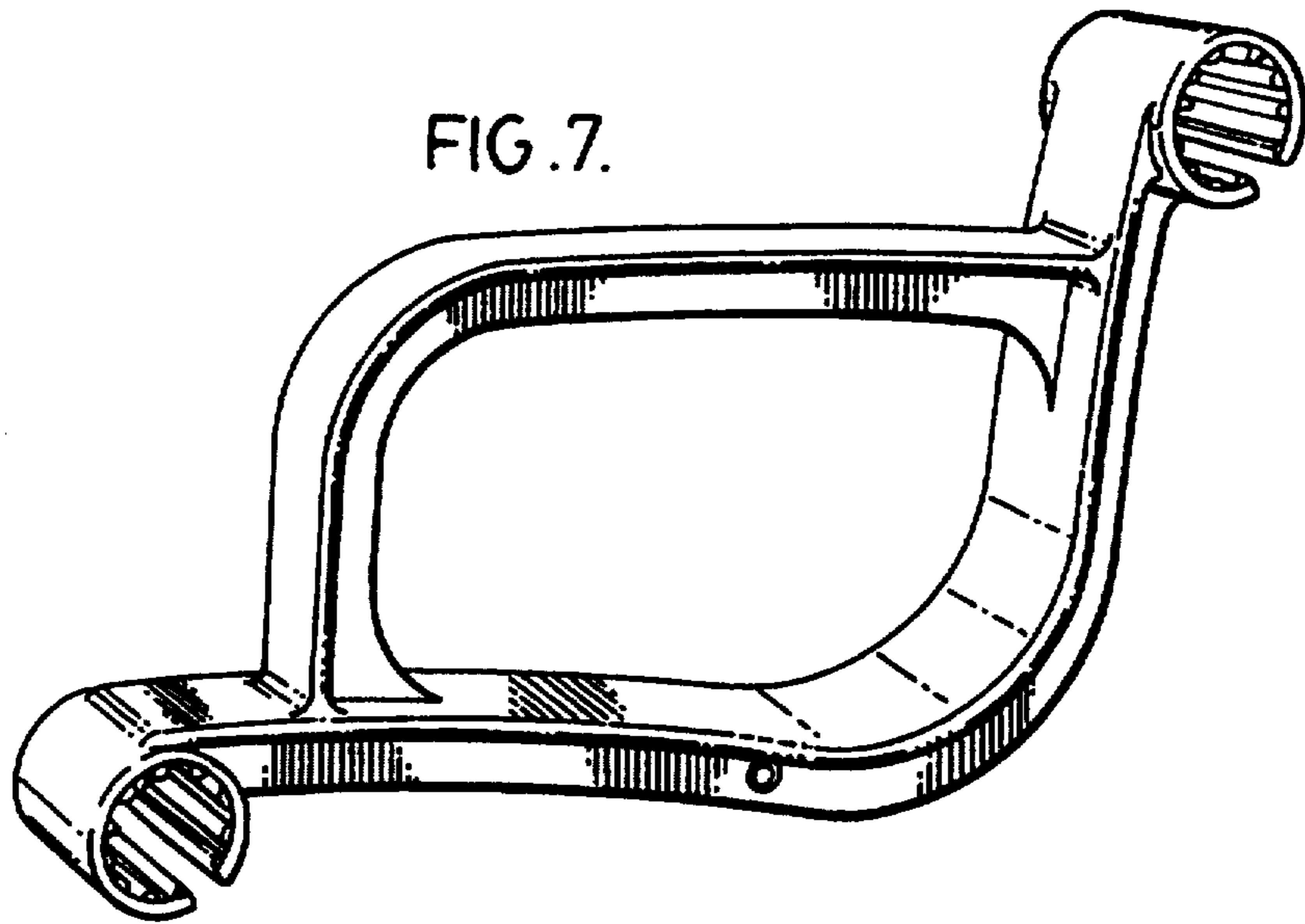

FIG. 7.

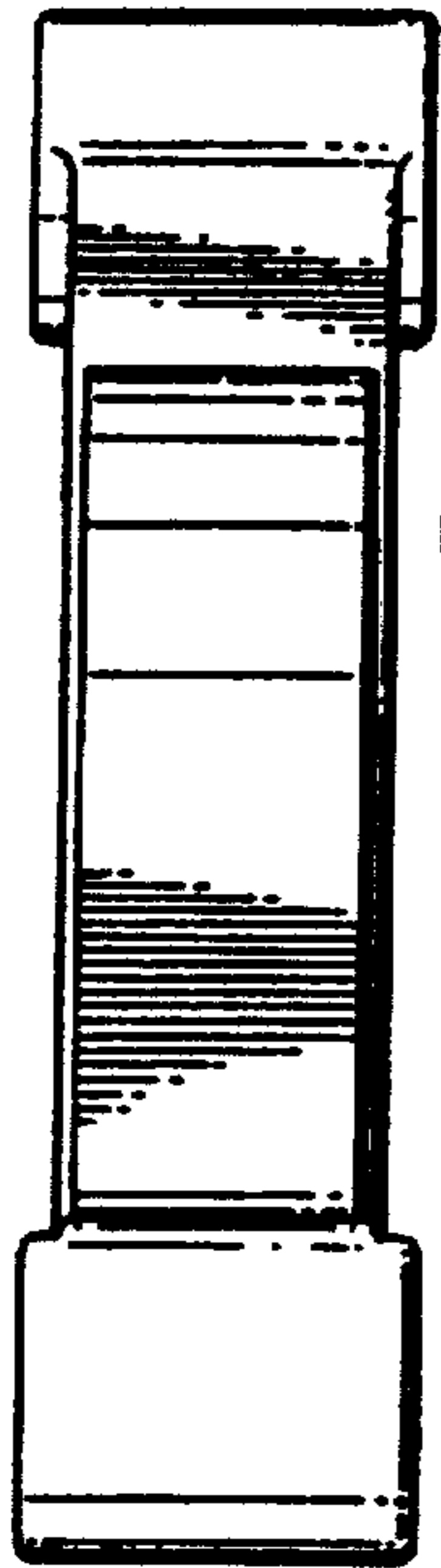

FIG. 9.

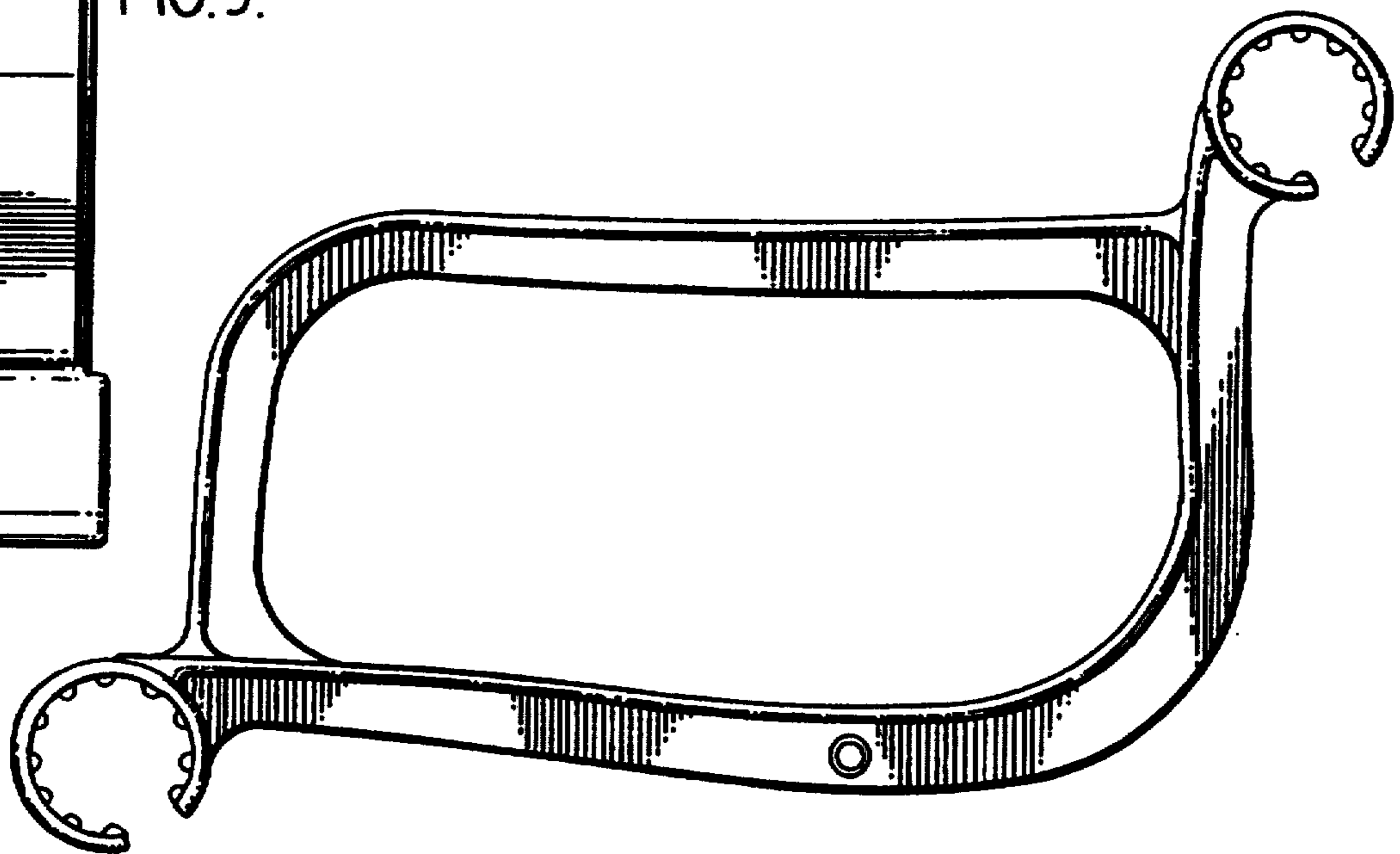

FIG. 8.



FIG. 10.